

Sectionalizing Equipment

Electrical Apparatus

1000-20

600 A 15 kV Class Clēer™ SecTER™ Cabinet

GENERAL

The versatile single- and three-phase 600 A 15 kV Class Clēer™ SecTER™ cabinets from Cooper Power Systems are designed as cable sectionalizing centers. They can be used wherever underground cable must be sectionalized or connected. Functions include sectionalizing cable, switching cable, isolating cable and feeder taps.

Each 15 kV Clēer SecTER cabinet comes complete with one Cooper Power Systems exclusive 600 A, 15 kV Class Clēer Loadbreak Connector installed per phase.

The aesthetic low profile design provides unobtrusive installations for sectionalizing, tapping or terminating underground cable.

The top hinged diagonally cut removable cover and cabinet are designed for easy one man opening and improved access to interior terminations. A door stop prevents the door from accidentally closing.

All cover-to-cabinet seams are designed to exceed ANSI® tamperproof standards. Munsell Green (7YG3.29/1.5) TGIC powder coating exceeds ANSI® coating requirements.

Continuous seam welding ensures a sturdy smooth cabinet.

Standard Features

- 12 Gauge Mild Steel Construction
- One Clēer Loadbreak Connector per phase
- Stainless Steel hardware and hinges
- Padlock hasp and pentahead silicon bronze door bolt
- Parking stands (two for Single-phase, four for Three-phase)
- Ground nuts (one per phase)



Figure 1. Three-Phase 15 kV Class Clēer SecTER Cabinet.

600 A 15 kV Clēer Loadbreak Connector System

The Cooper Power Systems Clēer Loadbreak Connector System is a 600 A loadbreak device rated for operation on 15 kV class systems. It is used to provide a visible break and visible ground on 600 A network and distribution systems without having to remove 600 A terminations and move heavy cable. The Clēer Loadbreak Connector System is fully shielded, submersible and meets the applicable requirements of IEEE Std 386™ -2006 standard – “Separable Insulated Connector Systems”.

When isolating underground cable, with the system energized or de-energized, with or without rated load current, with the use of a clampstick, the loadbreak connector (LCN) can be removed. A 600 A loadbreak protective cap (LPC615) can then be installed on the two exposed loadbreak interfaces. All



Figure 2. 600 A, 15 kV Clēer Square Configuration.

bushings of the connector system are then insulated and deadfront. If a 600 A termination with a 200 A reducing tap plug is used on the IEEE Std 386™ -2006 standard 600 A 15/25 kV deadbreak interfaces of the junction, a grounding elbow can be installed, providing a visible ground. It is then safe to perform work on the underground cable.

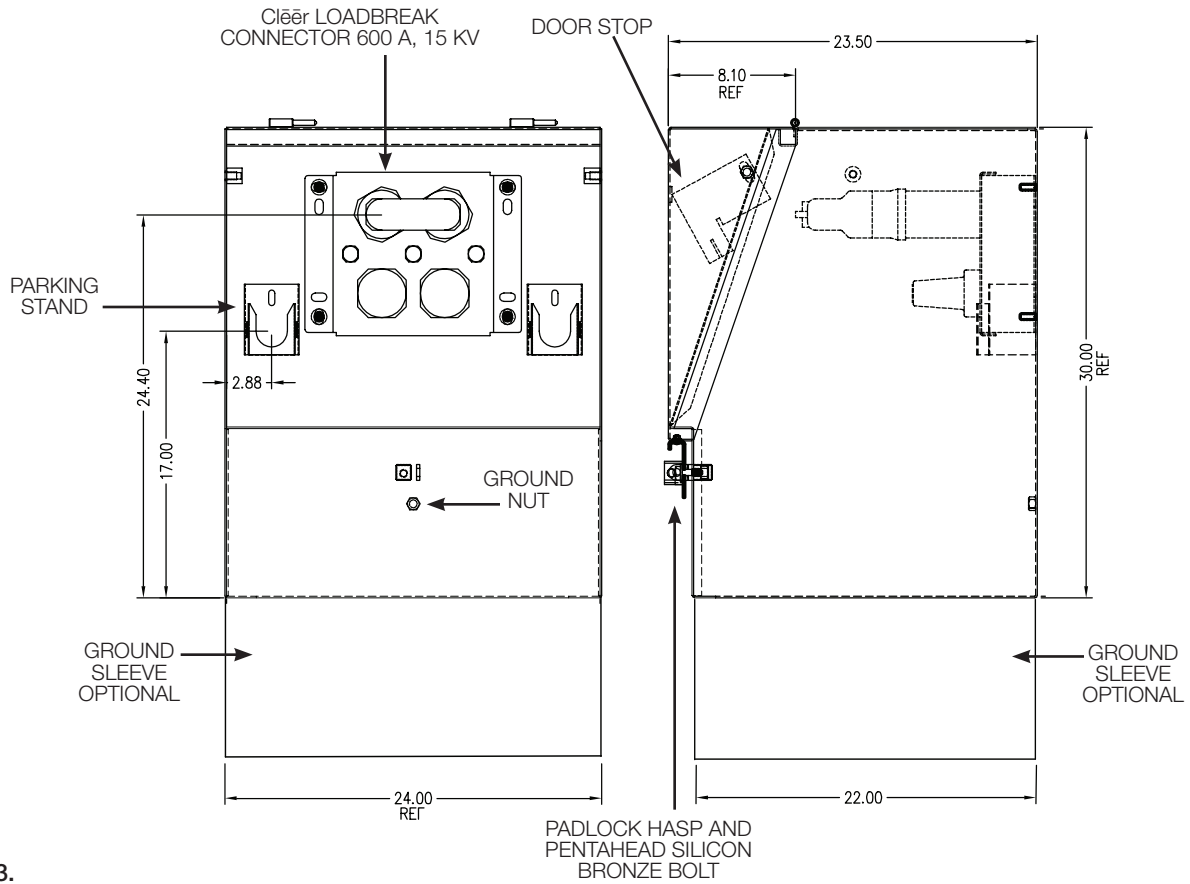

Figure 3.
Single-phase SecTER cabinet.

Note: Dimensions given are for reference only.

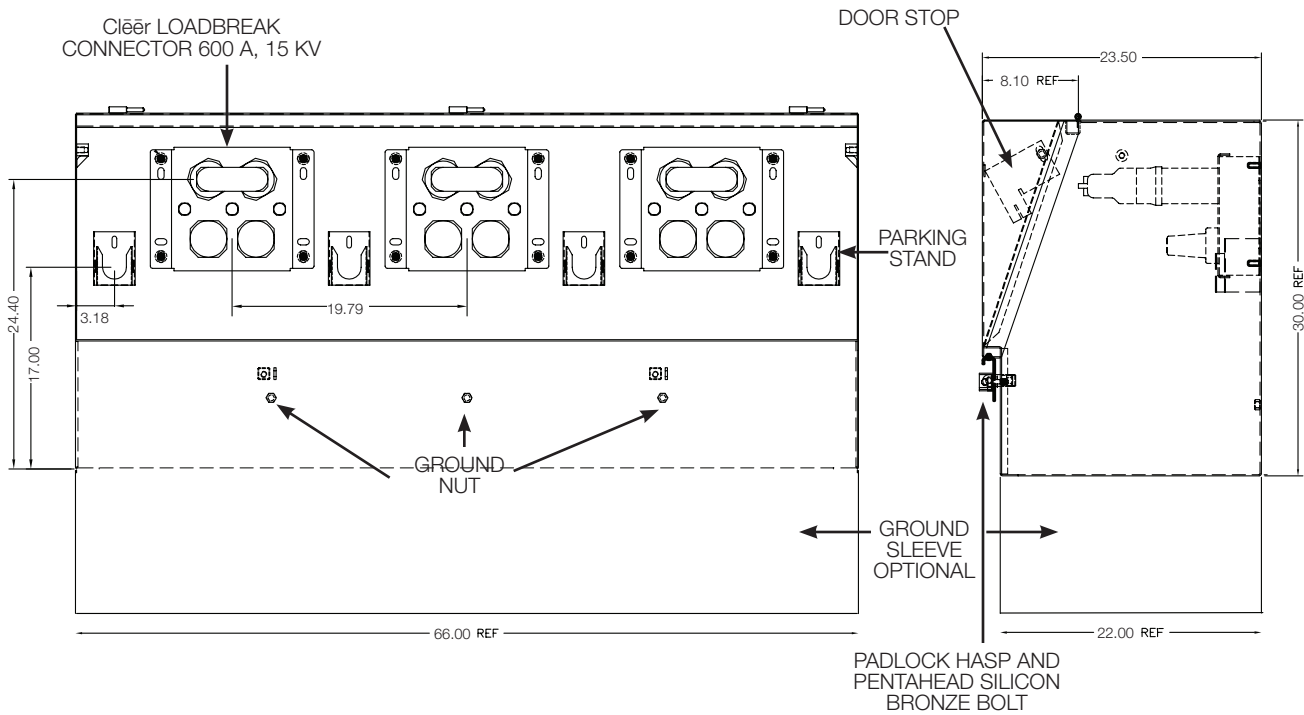

Figure 4.
Three-phase SecTER cabinet.

Note: Dimensions given are for reference only.

PRODUCTION TESTS

Tests are conducted in accordance with IEEE Std 386™ -2006 standard.

- AC 60 Hz 1 Minute Withstand – 34 kV
- Minimum Partial Discharge Extinction Voltage – 11 kV (3pc Sensitivity)

Tests are conducted in accordance with Cooper Power Systems requirements.

- Physical Inspection
- Periodic Dissection
- Periodic Fluoroscopic Analysis

TABLE 2
Voltage Ratings and Characteristics

Description	kV
Standard Voltage Class	15
Maximum Rating Phase-to-Phase	14.4
Maximum Rating Phase-to-Ground	8.3
AC 60 Hz 1 Minute Withstand	34
DC 15 Minute Withstand	53
BIL and Full Wave Crest	95
Minimum Partial Discharge Extinction Voltage	11

Voltage ratings and characteristics are in accordance with applicable IEEE Std 386™ -2006 standard requirements.

TABLE 4
Current Ratings and Characteristics

Description	Amperes
600 A Loadbreak Interface	
Continuous Current	600 A rms
Loadbreak Switching	Ten make and break operations at 600 A at 14.4 kV Phase-Phase
	Three make and break operations at 900 A at 14.4 kV Phase-Phase
Fault Closure	16 kA rms symmetrical at 14.4 kV Phase-Phase after ten 600 A loadbreak switching operations for 0.17 seconds
	16 kA rms symmetrical at 14.4 kV Phase-Phase after three 900 A loadbreak switching operations for 0.17 seconds
4 Hour Overload Current	900 A rms
Short Time Current	16 kA rms symmetrical for 0.17 seconds (limited by fault closure rating)
	10 kA rms symmetrical for 3.0 seconds
IEEE Std 386™ -2006 standard 600 A, 15/25 kV Deadbreak Interface	
Continuous Current	600 A rms
4 Hour Overload Current	900 A rms
Short Time Current	16 kA rms symmetrical for 0.17 seconds
	10 kA rms symmetrical for 3.0 seconds

Current ratings and characteristics are in accordance with applicable IEEE Std 386™ -2006 standard requirements.

ORDERING INFORMATION

TABLE 3
600 A 15 kV Class Clēer SecTER Cabinet

kV Class	Dimensions (in.)			Phase	Catalog Number
	H	W	D		
SecTER Cabinet					
15	30	24	22	1	SEC1P15CLEERA2
15	30	66	22	3	SEC3P15CLEERA2
Ground Sleeves					
Fiberglass	18	24	22	1	00400L00K02G
Fiberglass	30	24	22	1	00400L00K05G
Mild Steel	24	24	22	1	0400L00K10GM
Fiberglass	18	66	22	3	00450L00K05G
Fiberglass	30	66	22	3	00450L00K08G
Mild Steel	24	66	22	3	0450L00K18GM
Accessory					
600 A 15 kV Insulated Loadbreak Protective Cap					LPC615

Note:

Recessed base allows for an additional 1-1/2" stacking from backplate.

Typical Configurations

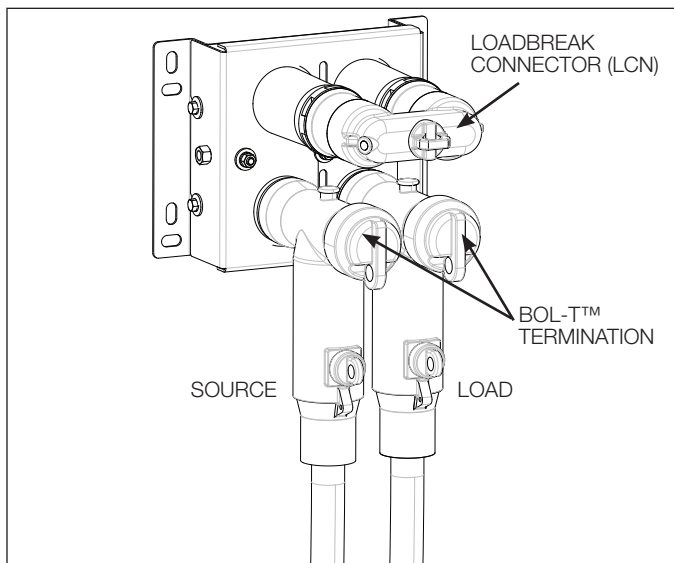

Figure 5.
600 A, 15 kV Loadbreak Connector System with (2) BOL-T terminations.

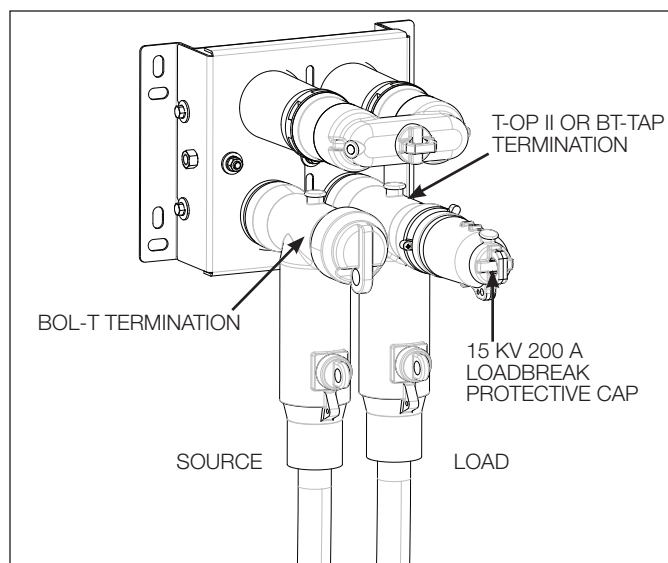

Figure 7.
600 A, 15 kV Loadbreak Connector System with (1) BOL-T and (1) T-OP II or BT-TAP termination and (1) 15 kV, 200 A Loadbreak Protective Cap.

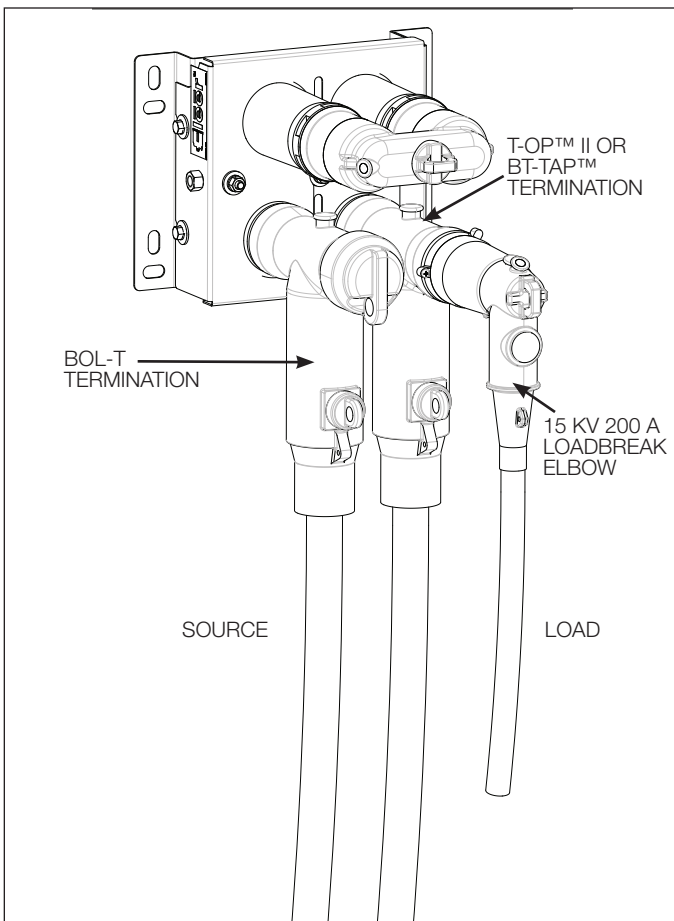

Figure 6.
600 A, 15 kV Loadbreak Connector System with (1) BOL-T, (1) T-OP II or BT-TAP termination and (1) 15 kV 200 A Loadbreak Elbow Tap.

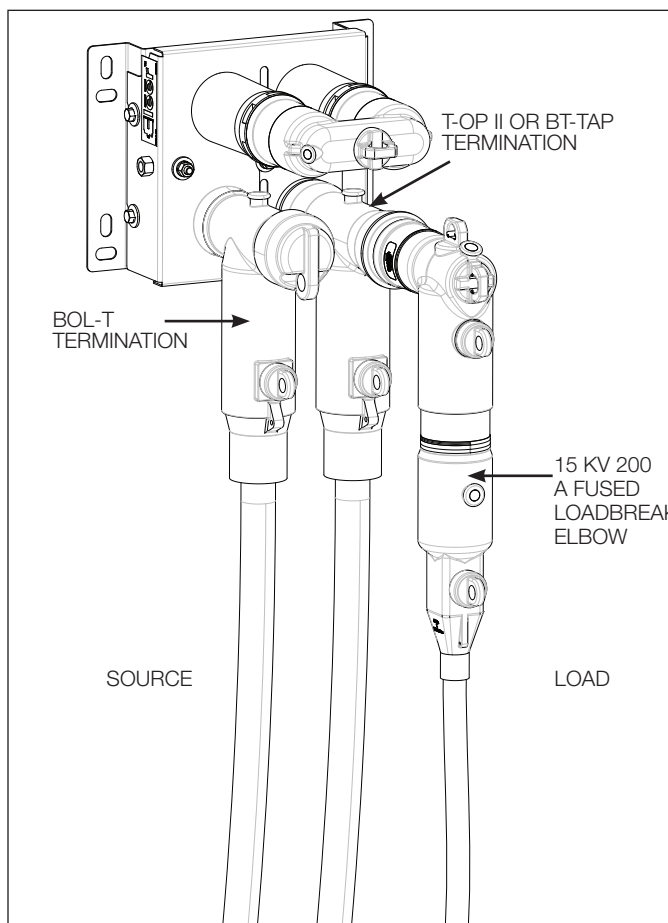

Figure 8.
600 A, 15 kV Loadbreak Connector System with (1) BOL-T, (1) T-OP II, or BT-TAP Termination and (1) 15 kV, 200 A Fused Loadbreak Elbow.

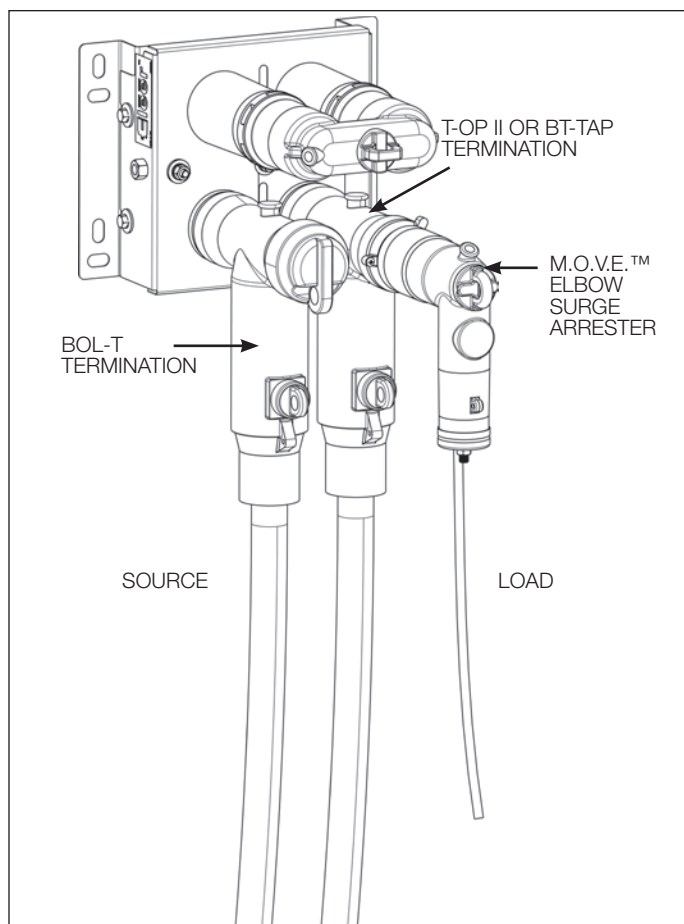

Figure 9.
600 A, 15 kV Loadbreak Connector System with (1) BOL-T,
(1) T-OP II, or BT-TAP Termination and (1) 15 kV M.O.V.E.
Elbow Surge Arrester.

This page intentionally left blank.

This page intentionally left blank.

© 2011 Cooper Industries. All Rights Reserved.

Cooper Power Systems, Clēer, SecTER, BOL-T, T-OP, BT-TAP, and M.O.V.E. are valuable trademarks of Cooper Industries in the U.S. and other countries. You are not permitted to use the Cooper Trademarks without the prior written consent of Cooper Industries.

IEEE Std 386-2006™ standard is a trademark of the Institute of Electrical and Electronics Engineers, Inc., (IEEE). This publication/product is not endorsed or approved by the IEEE.

ANSI® is a registered trademark of the American National Standards Institute.

One Cooper | www.cooperpower.com | Online

 **COOPER** Power Systems

2300 Badger Drive
Waukesha, WI 53188
