

# 600 A 15 and 25 kV class Cleer™ grounding elbow



## General

Eaton provides a visible ground on its Cooper Power™ series 600 A, 15 and 25 kV Cleer™ loadbreak connector system with its Cooper Power series Cleer grounding elbow. This tool is designed to be installed directly on the 600 A loadbreak interfaces after the circuit is verified to be de-energized. A Cleer grounding elbow installed on the loadbreak bushing interfaces on each end of the cable will isolate and ground the cable. The grounding elbow has a 16 kA through fault and fault closure rating for 15 kV systems.

## Construction

The grounding elbow is molded with high quality yellow EPDM rubber and features a copper top connector and tin plated probe complete with an arc follower tip.

Each unit comes standard with a 6 foot, 2/0 or 4/0 600 volt yellow or clear insulated grounding cable. Assemblies with different cable lengths and clamps installed are available.

All grounding elbow sets supplied with a factory installed ferrule and clamp conform to the latest requirements of ASTM F855. When grounding elbow is ordered without clamp, it does not meet ASTM F855. It is the user's responsibility to install an approved ferrule and clamp. For all kits not conforming to the latest ASTM F855 Edition, the cable will be terminated with a blunt cable end. Grounding kits including Cleer protective caps and parking stands are also available.

## Installation

Determine whether circuit is de-energized. Attach the ground cable to system ground. Using a clampstick, install the grounding elbow directly to the 600 A Cleer loadbreak bushing interface. Refer to *Service Information S600-103-1, 600 A, 15 and 25 kV Class Cleer™ Grounding Elbow Installation Instructions*.

## Production tests

Tests are conducted in accordance with Eaton requirements.

- Physical Inspection
- Periodic Dissection
- Periodic Fluoroscopic Analysis

Voltage Ratings are in accordance with IEEE Std 386™-2006 standard.

## Ordering information

Standard kit contains:

- Ground elbow installed on six feet yellow 2/0 or 4/0 cable
- Silicone lubricant
- Installation instruction
- Clamps and ferrules installed (optional)
- Kitted in an individual carton

Kits are also available to include Cleer parking stand and protective caps kitted in a canvas bag. See page 6 for details.

**Table 1. Current Ratings and Characteristics**

Description	kV Class	Amperes
Fault Closure	15	16,000 A rms symmetrical at 8.3 kV for 0.17s
Fault Closure	25	10,000 A rms symmetrical at 15.2 kV for 0.17s
Short Time	15 and 25	16,000 A rms symmetrical for 0.17s
		10,000 A rms symmetrical for 3.0s

Current ratings and characteristics are in accordance with applicable IEEE Std 386™-2006 standard requirements.

**PULLING EYE**

Stainless Steel Reinforced Pulling Eye with interlocking tabs enables safe hotstick operation. Sturdy construction substantially exceeds IEEE Std 386™-2006 standard requirements.

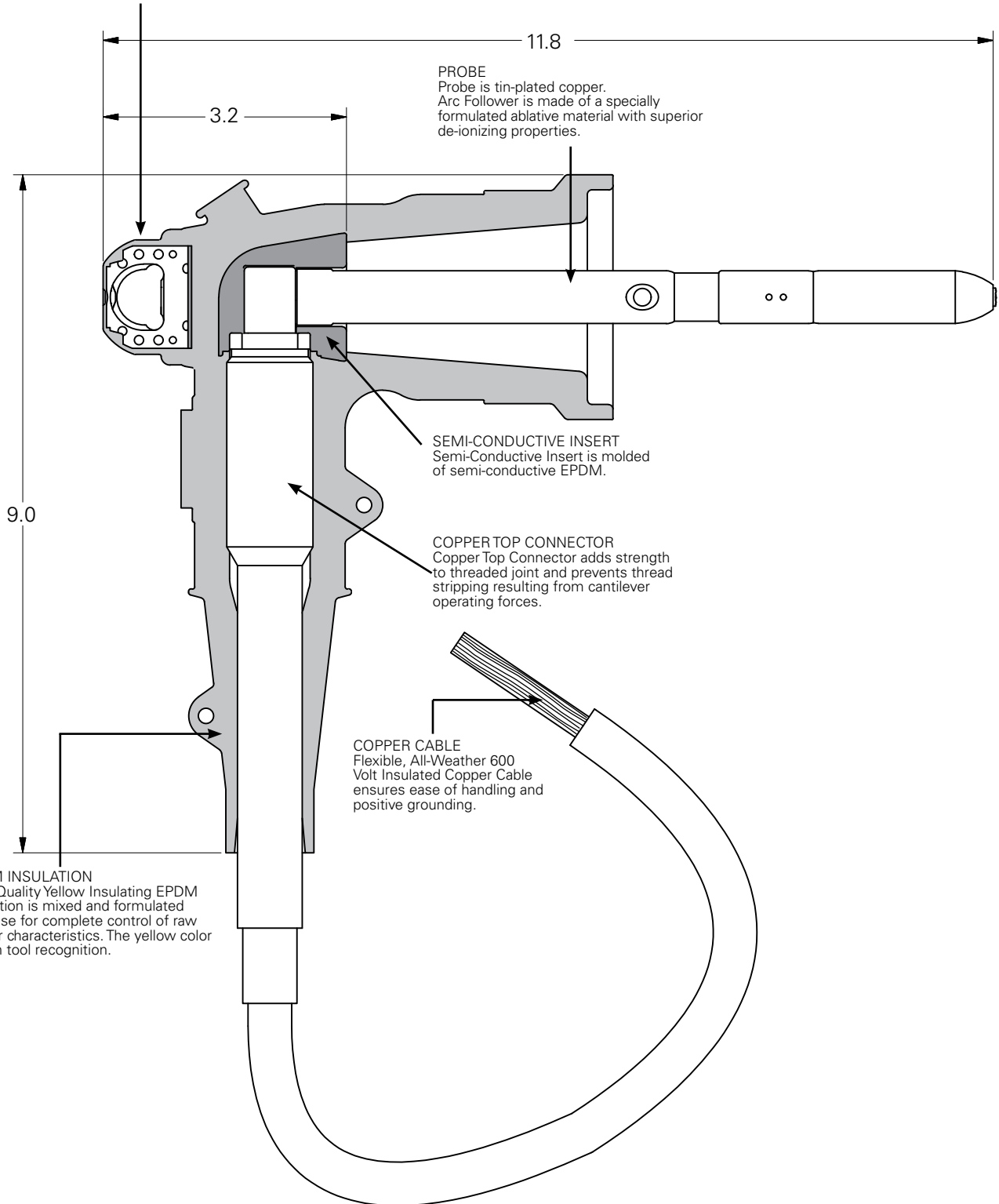

Figure 1. GE625 15 and 25 kV grounding elbow.

## Grounding clamps available

### C-Type grounding clamps

Eaton offers a wide variety of grounding clamps in various styles and sizes for different applications. Because of the diversity of products, users are assured of being able to select the exact clamp for the application. Cleer grounding elbows can be supplied assembled to your requirements.

#### Design features

Three general design considerations offer maximum application versatility:

- **Aluminum or bronze construction** – for the best conductivity regardless of conductor material
- **A variety of sizes to fit any job**
- **Sized for the job** – small clamps, ASTM rating 4, ultimate 47,000 A for 15 cycles; medium clamps, ASTM rating 5, ultimate 60,000 A for 15 cycles; large clamps, ASTM rating 6, ultimate 70,000 A for 15 cycles.
- **Resists burring and stripping** – brass eye screws have Acme threads.
- **Superior strain relief** – via stainless steel cable clamps.
- **Economical maintenance** – replaceable serrated jaw inserts save time and money.
- **Better conductivity and corrosion resistance** – brass jaw seats are plated when used in aluminum clamps.
- **Mounting flexibility** – threaded ferrule holes available for 1/2"-13 or 5/8"-11 threaded ferrules.
- **Identification ease** – wire range and catalog number are clearly marked on each clamp.



**Figure 2.**  
Cat. #133035-2AL (Aluminum), Style 15C  
Cat. #133035-2BRZ (Bronze), Style 16C



**Figure 3.**  
Cat. #3620-2 (Aluminum), Style 21C  
Cat. #3620-3 (Bronze), Style 22C

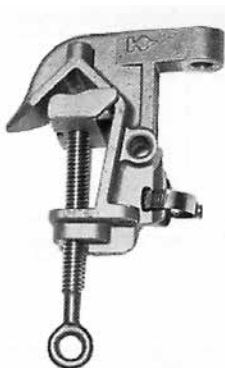

**Figure 4.**  
Cat. #133034-2AL (Aluminum), Style 11C  
Cat. #133034-2BRZ (Bronze), Style 12C



**Figure 5.**  
Cat. #3688-2 (Aluminum), Style 20C



**Figure 6.**  
Cat. #3668-1 (Bronze), Style 01C  
Cat. #3668-100 (Bronze), Style 02C  
Cat. #3654-100 (Aluminum), Style 04C



**Figure 7.**  
Cat. #3669-100 (Bronze), Style 07C  
Cat. #3665-1 (Aluminum), Style 08C  
Cat. #3665-100 (Aluminum), Style 09C

## Flat face grounding clamps

Eaton's Cooper Power series heavy-duty flat face ground clamps attach to flat metal surfaces such as busbars, towers, metal poles or other conductive structures.

### Design features:

- **Aluminum or bronze construction** – for the best conductivity regardless of conductor material.
- **A variety of sizes fit any job**
- **Jaws with either smooth or serrated surfaces**
- **Sized for the job** – small clamps, ASTM rating 4, ultimate 47,000 A for 15 cycles; medium clamps, ASTM rating 5, ultimate 60,000 A for 15 cycles; large clamps, ASTM rating 6, ultimate 70,000 A for 15 cycles.
- **Resists burring and stripping** – brass eye screws have Acme threads, a superior thread design.
- **Superior strain relief** – via stainless steel cable clamps.
- **Better conductivity and corrosion resistance** – brass jaw seats are plated when used in aluminum clamps.
- **Mounting flexibility** – threaded ferrule holes available for 1/2"-13 or 5/8"-11 threaded ferrules.
- **Identification ease** – wire range and catalog number are clearly marked on each clamp.



**Figure 8.**  
Cat. #133036-8AL (Aluminum), Style 04F  
Cat. #133036-8BRZ (Bronze), Style 05F



**Figure 9.**  
Cat. #3659 (Aluminum), Style 01F  
Cat. #3673-100 (Bronze), Style 03F



**Figure 10.**  
Cat. #133042-8AL (Aluminum), Style 06F  
Cat. #133042-8BRZ (Bronze), Style 07F



**Figure 11.**  
Cat. #3672-100 (Bronze), Style 02F

## Miscellaneous clamp

Eaton's Cooper Power series includes a special locking plier clamp.



**Figure 12.**  
Cat. #133045CPS (Steel), Style 1LP

**Table 2. Grounding Clamp Styles**

Clamp Style	Material	Clamp Range	Cable Range	ASTM Rating 15 Cycle Withstand	Eye Screw Thread	Ferrule Thread Type	Figure	Catalog Number
01C	Bronze	#8 Sol. to 1" dia.	#2 to 4/0	4 (34 kA)	Fine	1/2" Thru Hole	6	3668-1
02C	Bronze	#8 Sol. to 1" dia.	#2 to 4/0	4 (34 kA)	Fine	1/2-13	6	3668-100
04C	Aluminum	#8 Sol. to 1" dia.	#2 to 4/0	4 (34 kA)	Fine	1/2-13	6	3654-100
07C	Bronze	#8 Sol. to 2" dia.	#2 to 4/0	4 (34 kA)	Fine	1/2-13	7	3669-100
08C	Aluminum	#8 Sol. to 2" dia.	#2 to 4/0	4 (34 kA)	Fine	1/2" Thru Hole	7	3655-1
09C	Aluminum	#8 Sol. to 2" dia.	#2 to 4/0	4 (34 kA)	Fine	1/2-13	7	3655-100
21C	Bronze	#8 Sol. to 1-3/8" dia.	#2 to 4/0	4 (34 kA)	Fine	1/2-13	3	3620-2
22C	Bronze	#8 Sol. to 1" dia.	#2 to 4/0	4 (34 kA)	Fine	1/2-13	3	3620-3
15C	Aluminum	#8 Sol. to 1" dia.	#2 to 250 MCM	5 (43 kA)	Acme	1/2-13	2	133035-2AL
16C	Bronze	#8 Sol. to 1" dia.	#2 to 250 MCM	5 (43 kA)	Acme	1/2-13	2	133035-2BRZ
20C	Aluminum	#6 Sol. to 5" dia.	#2 to 4/0	5 (43 kA)	Acme	1/2-13	5	3688-2
11C	Aluminum	#8 Sol. to 2" dia.	#2 to 250 MCM	6 (54 kA)	Acme	1/2-13	4	133034-2AL
12C	Bronze	#8 Sol. to 2" dia.	#2 to 250 MCM	6 (54 kA)	Acme	1/2-13	4	133034-2BRZ
01F	Aluminum	#8 Sol. to 1-1/2" dia.	# 2 to 4/0	4 (34 kA)	Fine	1/2-13	9	3659
02F	Bronze	#8 Sol. to 1-1/2" dia.	# 2 to 4/0	4 (34 kA)	Fine	1/2-13	11	3672-100
03F	Aluminum	#8 Sol. to 1-1/2" dia.	# 2 to 4/0	4 (34 kA)	Fine	1/2-13	9	3673-100
04F	Aluminum	#8 Sol. to 2" dia.	# 2 to 250 MCM	4 (34 kA)	Acme	5/8-11	8	133036-8AL
05F	Bronze	#8 Sol. to 2" dia.	# 2 to 250 MCM	4 (34 kA)	Acme	5/8-11	8	133036-8BRZ
06F	Aluminum	#8 Sol. to 2" dia.	# 2 to 250 MCM	4 (34 kA)	Acme	5/8-11	10	133042-8AL
07F	Bronze	#8 Sol. to 2" dia.	# 2 to 250 MCM	4 (34 kA)	Acme	5/8-11	10	133042-8BRZ
1LP	Steel	.25" to 1.25" dia.	1/0 to 2/0	N/A	N/A	Bolted	12	133045

\* Electrical ratings are RMS, symmetrical.

**TABLE 3. Grounding Elbow Ordering Information**

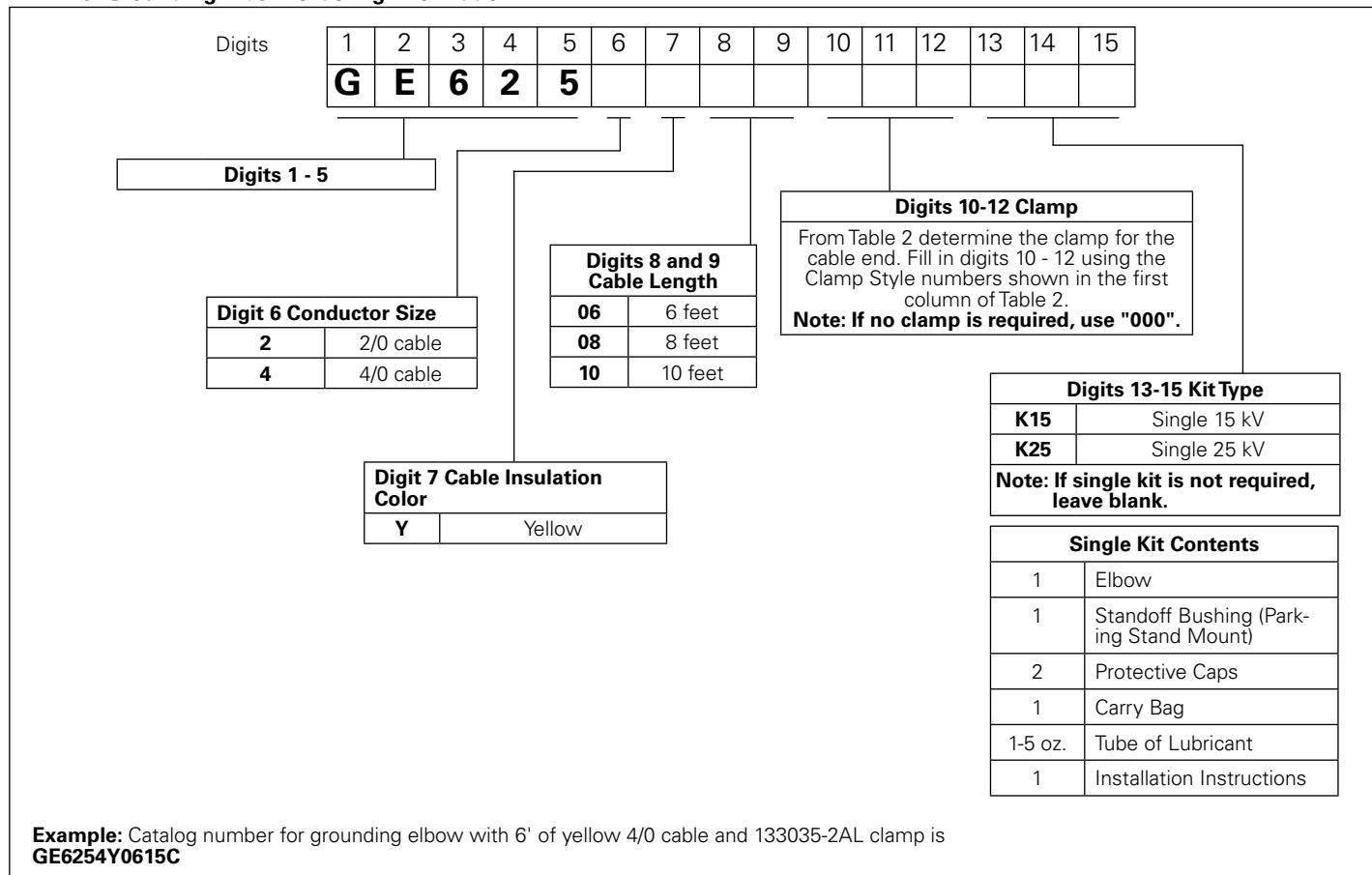

## Standoff bushing

Eaton's Cooper Power series 600 A, 15 and 25 kV Class Cleer loadbreak standoff bushing meets the applicable requirements of IEEE Std 386™-2006 standard - Separable Insulated Connector Systems and provides double interfaces for temporarily parking the Cleer loadbreak connector in sectionalizing cabinets and in underground vaults. The standoff bushing is designed to be installed in the parking stand of the sectionalizing cabinet or in a parking stand mounted in a vault.



**Figure 13. 600 A, 15 and 25 kV Cleer Loadbreak Standoff Bushing.**

## Protective cap

The 600 A, 15 kV Cleer loadbreak protective cap is an accessory device designed to electrically insulate and mechanically seal the 600 A Cleer loadbreak bushing interfaces.

Eaton incorporates its Cooper Power series field proven POSI-BREAK™ technology, providing a layer of insulation over the conductive internal insert and an insulative sleeve on the base of the probe. This results in increased strike distance greatly reducing the possibility of partial vacuum flashovers and providing superior switching performance and reliability.

The protective cap is fully shielded and submersible and meets the applicable requirements of IEEE Std 386™ -2006 standard. Refer to Installation Instruction Sheet, S600-100-2 for details.



**Figure 14. 600 A, 25 kV Cleer Loadbreak Connector Protective Cap.**

## Additional information

Refer to the following reference literature for application recommendations:

**CA650010EN**, 600 A, 15 kV Class Cleer Loadbreak Connector System

**CA650011EN**, 600 A, 25 kV Class Cleer Loadbreak Connector System

**CA650012EN**, 600 A, 28 kV Class Cleer Loadbreak Connector System

**CA901002EN**, 600 A, 15, 25, and 28 kV Class Cleer SecTER™ Cabinet

**S600-100-1**, 600 A 15, 25, and 28 kV Class Cleer Loadbreak Connector System Installation Instructions

**S600-100-2**, 600 A 15, 25, and 28 kV Class Cleer Loadbreak Connector Insulated Protective Cap Installation Instructions

**S600-100-3**, 600 A 15 and 25 kV Class Cleer Loadbreak Standoff Bushing Installation Instructions

**S600-103-1**, 600 A, 15 and 25 kV Class Cleer Grounding Elbow Installation Instructions

**CP1120**, 600 A 15 kV Class Cleer Loadbreak Separable Connector System Certified Test Report

**CP1204**, 600 A 25 kV Class Cleer Loadbreak Separable Connector System Certified Test Report

**CP1205**, 600 A 28 kV Class Cleer Loadbreak Separable Connector System Certified Test Report

**PA650002EN**, The Cleer Solution for Distribution Systems

**Eaton**  
1000 Eaton Boulevard  
Cleveland, OH 44122  
United States  
Eaton.com

**Eaton's Cooper Power Systems Division**  
2300 Badger Drive  
Waukesha, WI 53188  
United States  
Cooperpower.com

© 2015 Eaton  
All Rights Reserved  
Printed in USA  
Publication No. CA650013EN

Eaton, Cooper Power, Cleer, and POSI-BREAK are valuable trademarks of Eaton in the U.S. and other countries. You are not permitted to use these trademarks without the prior written consent of Eaton. IEEE Std 386™ -2006 standard is a trademark of the Institute of Electrical and Electronics Engineers, Inc., (IEEE). This publication/product is not endorsed or approved by the IEEE.

For Eaton's Cooper Power series Cleer loadbreak connector system information call 1-877-277-4636 or visit: [www.cooperpower.com](http://www.cooperpower.com).