

# Loadbreak Apparatus Connectors

## 600 A 28 kV Class Clēer™ Loadbreak Connector System

### GENERAL

The Cooper Power Systems Clēer™ Loadbreak Connector System is a 600 A loadbreak device rated for operation on 28 kV class systems. It is used to provide a visible break and visible ground on 600 A network and distribution systems without having to remove 600 A terminations and move heavy cable. The Clēer Loadbreak Connector System is fully shielded, submersible and meets the applicable requirements of IEEE Std 386™ -2006 standard – “Separable Insulated Connector Systems”.

Many configurations are possible with this connector system. Under normal operating conditions, the current path is through one of the 600 A loadbreak/deadbreak 2-position junctions (DLJ628), through the 600 A loadbreak “C” (LCN) connector and through the second 600 A loadbreak/deadbreak junction.

When isolating underground cable, with the system energized or de-energized, with or without rated load current, with the use of a clampstick, the LCN connector can be removed. A 600 A loadbreak protective cap (LPC628) can then be installed on the two exposed loadbreak interfaces. All bushings of the connector system are then insulated and deadfront. If a 600 A termination with a 200 A reducing tap plug is used on the IEEE Std 386™ -2006 standard 600 A 15/25 kV (tested to 28 kV levels) deadbreak interfaces of the junction, a grounding elbow can be installed, providing a visible ground. It is then safe to perform work on the underground cable.

### CONSTRUCTION

The Clēer 600 A Loadbreak Connector System includes two loadbreak/deadbreak junctions, each consisting of one Cooper Power Systems exclusive 600 A loadbreak interface and one IEEE Std 386™ -2006 standard 600 A deadbreak interface.

The 600 A loadbreak “C” (LCN) connector incorporates Cooper Power Systems field proven POSI-BREAK™ technology, providing a layer of insulation over the conductive internal inserts and an insulative sleeve on the base of the probes. This results in increased strike

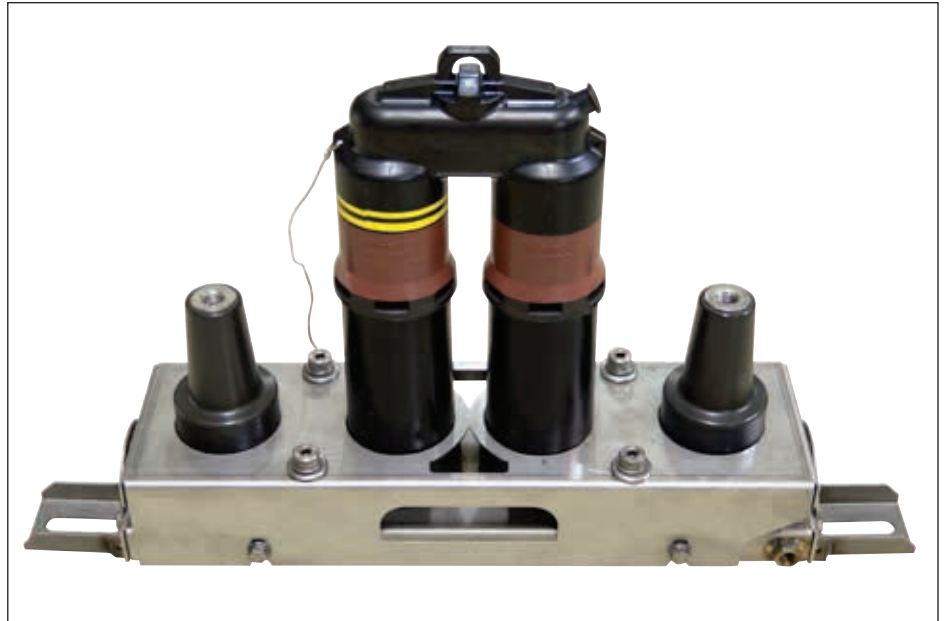

**Figure 1.**  
600 A 28 kV Class Clēer Loadbreak Connector System.

distance greatly reducing the possibility of partial vacuum flashovers and providing superior switching performance and reliability.

### INTERCHANGEABILITY

The IEEE Std 386™ -2006 standard 600 A deadbreak interfaces are interchangeable with 600 A terminations currently available from all other manufacturers that also comply with IEEE Std 386™ -2006 standard.

### INSTALLATION

No special tools are required for installation.

The Clēer 600 A Loadbreak Connector System is available in both in-line and square configurations. It is designed to be mounted directly to a vault or manhole walls or inside an enclosure. The in-line junction assembly has an adjustable stainless steel bracket for mounting at various operating angles. 600 A, BOL-T, T-OP II or BT-TAP cable terminations are assembled to the source and load side 600 A deadbreak bushings following the instructions provided in those kits. Using a clampstick, the loadbreak “C” connector (LCN) is assembled to the two center 600 A loadbreak interfaces to complete the current path. Refer to mounting

dimensions on page 5 and installation instructions, Service Information, S600-100-1 for details.

### PRODUCTION TESTS

Tests are conducted in accordance with IEEE Std 386™ -2006 standard.

- AC 60 Hz 1 Minute Withstand – 45 kV
- Minimum Partial Discharge Extinction Voltage – 21.5 kV (3pc Sensitivity)

Tests are conducted in accordance with Cooper Power Systems requirements.

- Physical Inspection
- Periodic Dissection
- Periodic Fluoroscopic Analysis

**TABLE 1**  
Voltage Ratings and Characteristics

Description	kV
Standard Voltage Class	28
Maximum Rating Phase-to-Phase	28.0
Maximum Rating Phase-to-Ground	16.2
AC 60 Hz 1 Minute Withstand	45
DC 15 Minute Withstand	100
BIL and Full Wave Crest	125
Minimum Partial Discharge Extinction Voltage	21.5

Voltage ratings and characteristics are in accordance with applicable IEEE Std 386™ -2006 standard requirements.

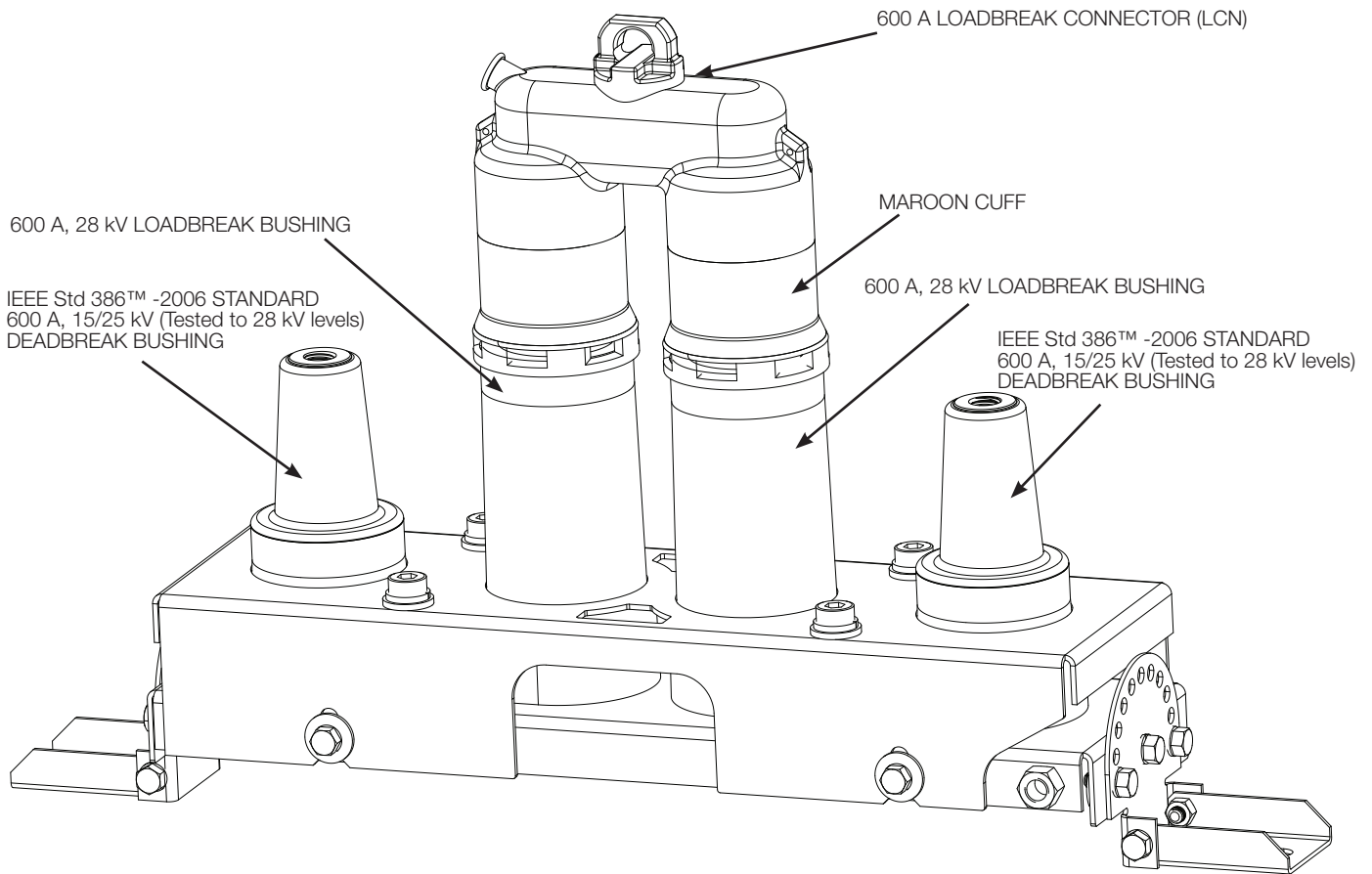

Figure 2.  
600 A, 28 kV Clēer Loadbreak Connector System with In-line Bracket.

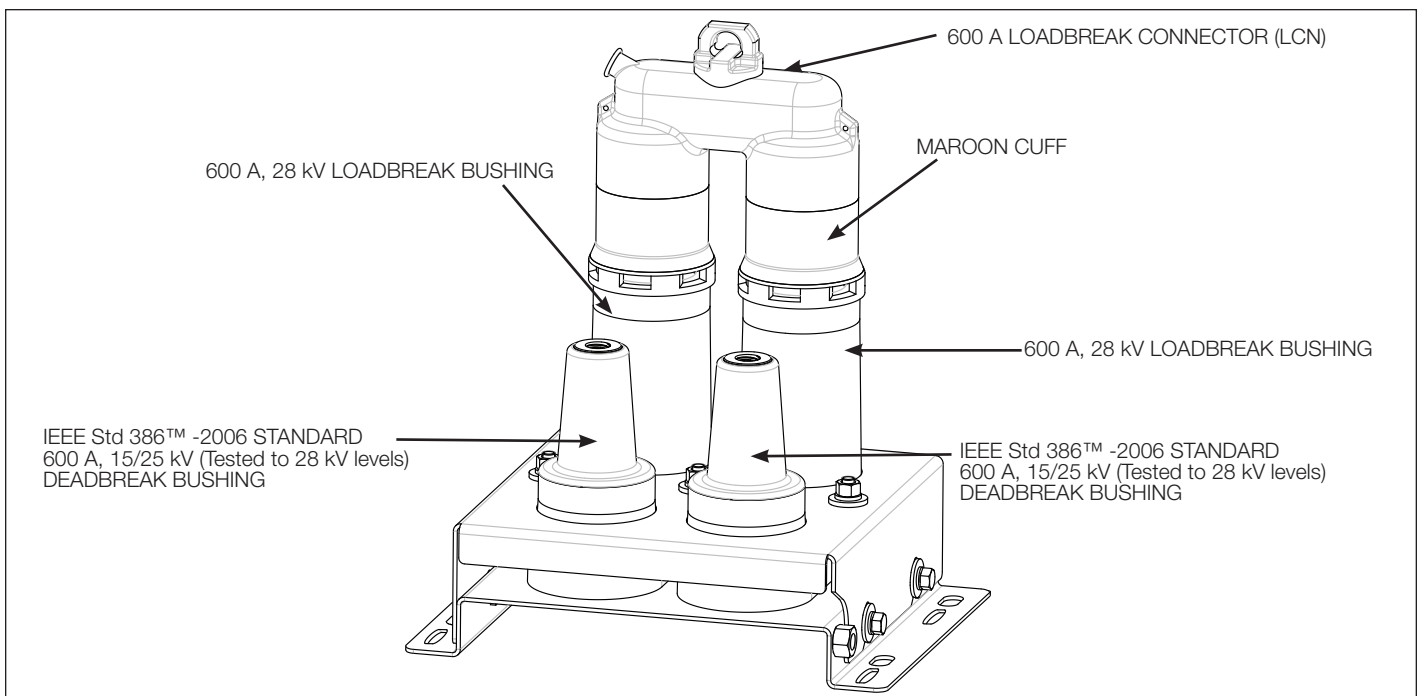

Figure 3.  
600 A, 28 kV Clēer Loadbreak Connector System with Square Bracket.

## ORDERING INFORMATION

To order the 600 A, 28 kV Class Clēer Loadbreak Connector System, refer to Table 3.

Each complete 600 A, 28 kV Class Clēer Loadbreak Connector (LCN2DLJ628) Assembly Kit contains:

- (2) 600 A, 28 kV, Loadbreak/Deadbreak 2-Position Junctions
- (1) 600 A, 28 kV, Loadbreak "C" Connector
- (1) Stainless steel mounting bracket
- (1) Stainless steel hardware kit (In-line bracket only)
- (2) Ground lugs (#8 sol to 2/0 str.)
- Silicone Lubricant
- Installation Instruction Sheet

## STANDOFF BUSHING

The Cooper Power Systems 600 A, 15 and 25 kV Class Clēer Loadbreak Standoff Bushing meets the applicable requirements of IEEE Std 386™ standard - Separable Insulated Connector Systems and provides double interfaces for temporarily parking the Cooper Power Systems Clēer Loadbreak Connector in sectionalizing cabinets and in underground vaults. The standoff bushing is designed to be installed in the parking stand of the sectionalizing cabinet or in a parking stand mounted in a vault.



Figure 4.  
600 A, 15 and 25 kV Clēer Loadbreak Standoff Bushing.

TABLE 2  
Current Ratings and Characteristics

Description	Amperes
<b>600 A Loadbreak Interface</b>	
Continuous Current	600 A rms
Loadbreak Switching	Five make and break operations at 600 A at 28.0 kV Phase-Phase
	One make and break operation at 900 A at 28.0 kV Phase-Phase
Fault Closure	10 kA rms symmetrical at 28.0 kV Phase-Phase after five 600 A loadbreak switching operations for 0.17 seconds
	10 kA rms symmetrical at 28.0 kV Phase-Phase after one 900 A loadbreak switching operation for 0.17 seconds
4 Hour Overload Current	900 A rms
Short Time Current	10 kA rms symmetrical for 0.17 seconds (limited by fault closure rating)
	10 kA rms symmetrical for 3.0 seconds
<b>IEEE Std 386™ -2006 standard 600 A, 15/25 kV Deadbreak Interface</b>	
Continuous Current	600 A rms
4 Hour Overload Current	900 A rms
Short Time Current	10 kA rms symmetrical for 0.17 seconds
	10 kA rms symmetrical for 3.0 seconds

Current ratings and characteristics are in accordance with applicable IEEE Std 386™ -2006 standard requirements.

TABLE 3  
600 A 28 kV Clēer Loadbreak Connector System

Description	Catalog Number
600 A, 28 kV Loadbreak Connector Assembly includes: two loadbreak/deadbreak junctions with loadbreak "C" connector assembled in a In-Line SS. Bracket	LCN2DLJ628A2ILB
600 A, 28 kV Loadbreak Connector assembly includes: two loadbreak/deadbreak junctions with loadbreak "C" connector assembled in a Square SS. Bracket	LCN2DLJ628A2SQB
600 A, 15 and 25 kV, Clēer Loadbreak Standoff Bushing (Parking Stand Mount)	PS625CLEER
600 A, 15 and 25 kV Clēer Loadbreak Standoff Bushing (Direct Wall Mount)	PS625CLEERDM
600 A, 28 kV Insulated Loadbreak Protective Cap	LPC628
600 A, 28 kV Loadbreak "C" Connector	LCN628

## PROTECTIVE CAP

The 600 A, 28 kV Clēer loadbreak protective cap is an accessory device designed to electrically insulate and mechanically seal the 600 A Clēer loadbreak bushing interfaces.

It incorporates Cooper Power Systems field proven POSI-BREAK technology, providing a layer of insulation over the conductive internal insert and an insulative sleeve on the base of the probe. This results in increased strike distance greatly reducing the possibility of partial vacuum flashovers and providing superior switching performance and reliability.

The protective cap is fully shielded and submersible and meets the applicable requirements of IEEE Std 386™ -2006 standard. Refer to Installation Instruction Sheet, S600-100-2 for details



Figure 4.  
600 A, 28 kV Clēer Loadbreak Connector Protective Cap.

## TYPICAL CONFIGURATIONS

### In-Line Bracket configurations

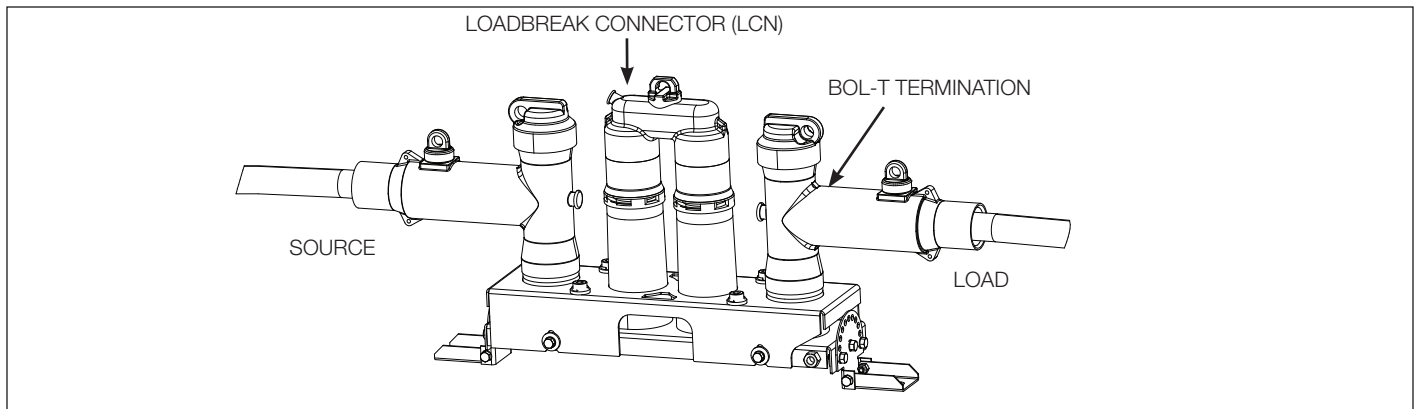

Figure 5.  
600 A, 28 kV Loadbreak Connector System with (2) BOL-T terminations.

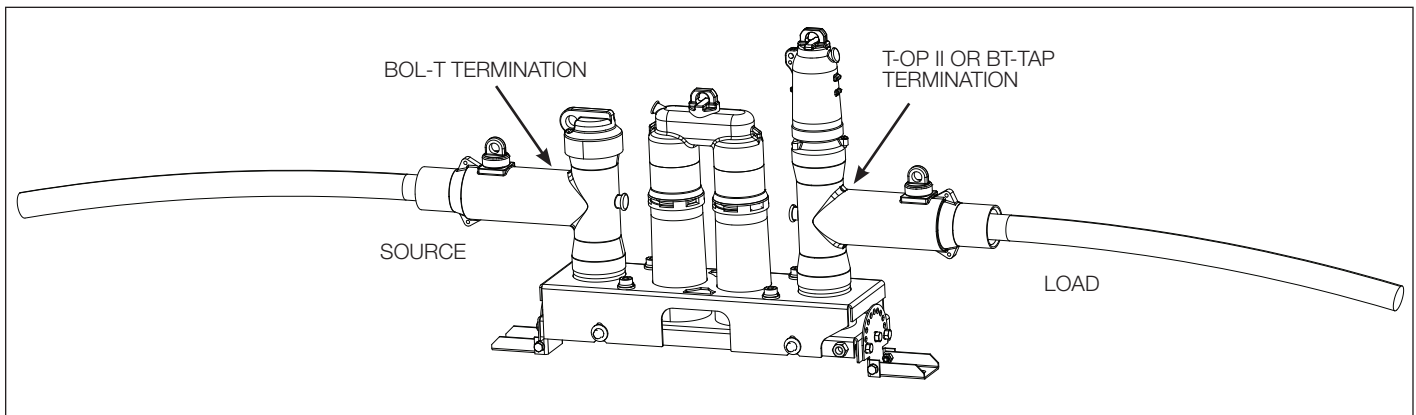

Figure 6.  
600 A, 28 kV Loadbreak Connector System with (1) BOL-T and (1) T-OP II or BT-TAP termination.

### Square Bracket Configurations

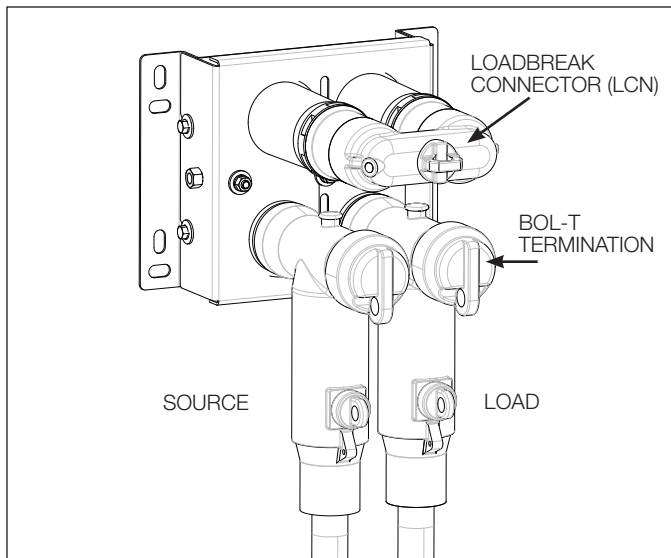

Figure 7.  
600 A, 28 kV Loadbreak Connector System with (2) BOL-T terminations.

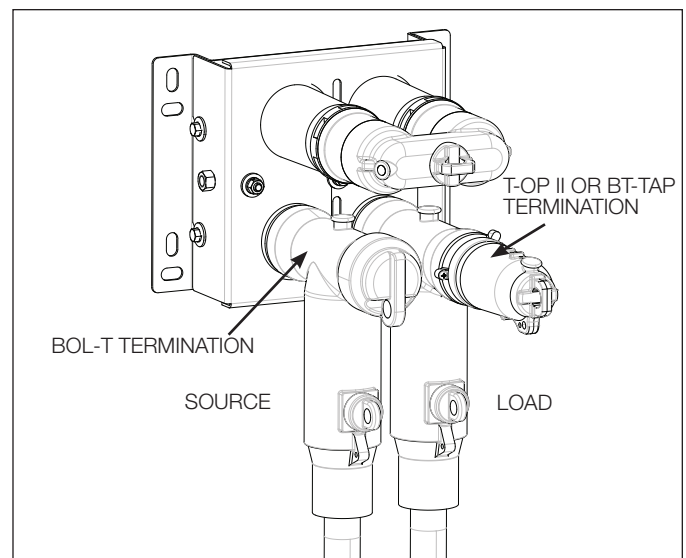
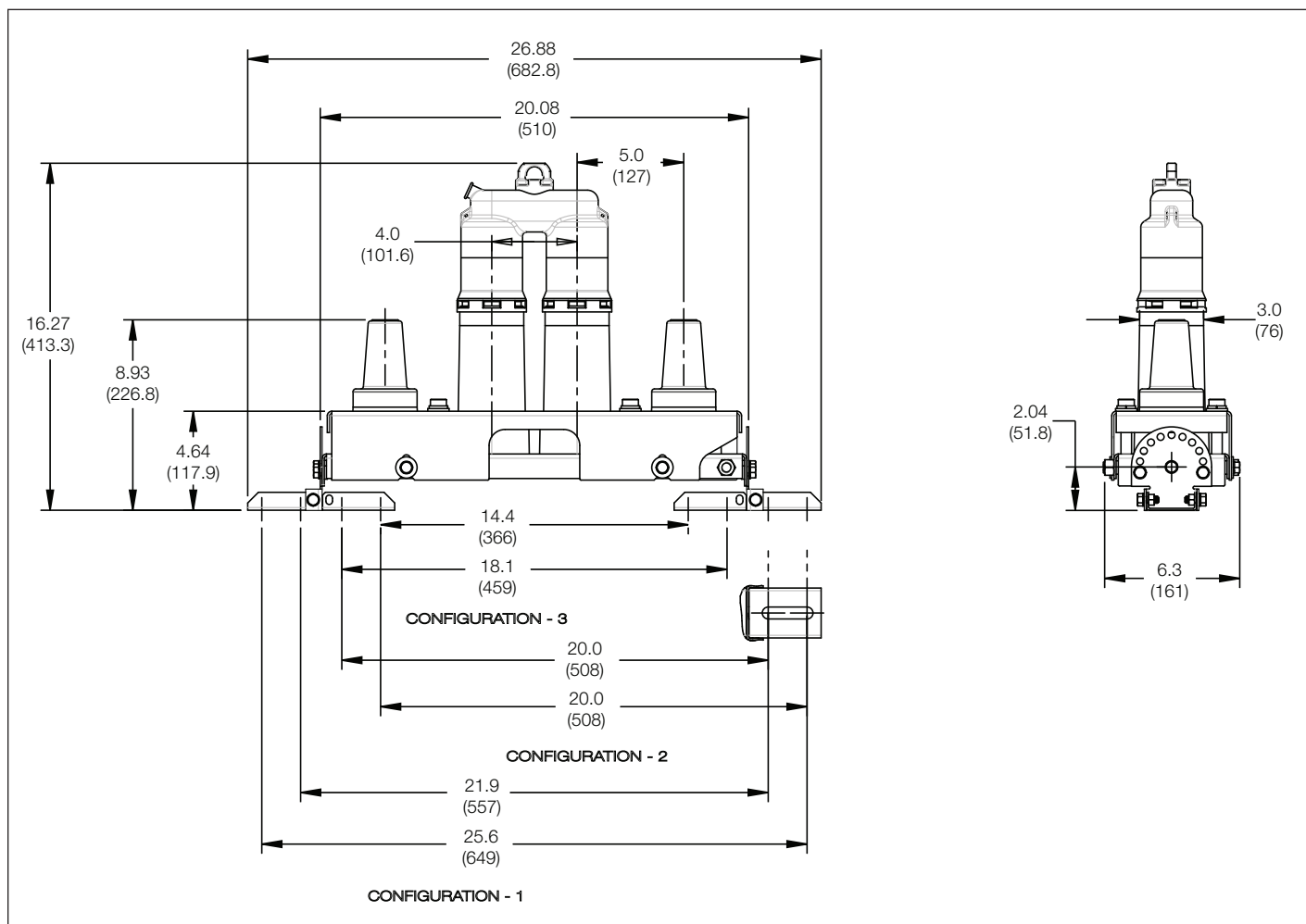
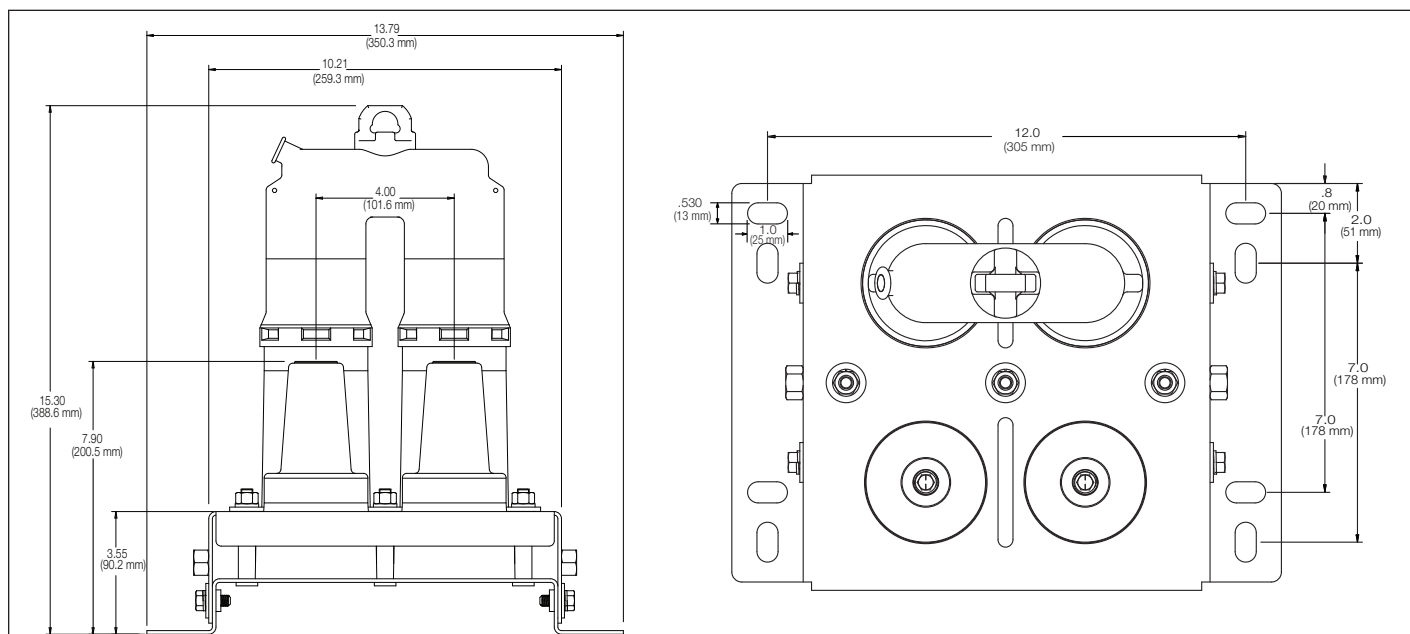

Figure 8.  
600 A, 28 kV Loadbreak Connector System with (1) BOL-T and (1) T-OP II or BT-TAP termination.



**Figure 9.**  
Dimensional drawing shows mounting configurations for in-line bracket.

**Note:** Dimensions given are for reference only.



**Figure 10.**  
Dimensional drawing shows mounting configurations for square bracket.

**Note:** Dimensions given are for reference only.

## **ADDITIONAL INFORMATION**

Refer to the following reference literature for application recommendations:

**600-100**, 600 A, 15 kV Class Clēer Loadbreak Connector System

**600-101**, 600 A, 25 kV Class Clēer Loadbreak Connector System

**S600-100-1**, 600 A 15, 25, and 28 kV Class Clēer Loadbreak Connector System Installation Instructions

**S600-100-2**, 600 A 15, 25, and 28 kV Class Clēer Loadbreak Connector Insulated Protective Cap Installation Instructions

**S600-100-3**, 600 A 15 and 25 kV Class Clēer Loadbreak Standoff Bushing Installation Instructions

**B600-11014**, 600 Amp Loadbreak Technology Provides Efficient, Reliable Visible Break and Visible Ground



© 2012 Cooper Industries. All Rights Reserved.  
Cooper Power Systems, Clēer, BOL-T, T-OP, POSI-BREAK, and BT-TAP are valuable trademarks of Cooper Industries in the U.S. and other countries. You are not permitted to use the Cooper Trademarks without the prior written consent of Cooper Industries. IEEE Std 386™ -2006 standard is a trademark of the Institute of Electrical and Electronics Engineers, Inc., (IEEE). This publication/product is not endorsed or approved by the IEEE.

One Cooper | [www.cooperpower.com](http://www.cooperpower.com) | Online

  
**COOPER** Power Systems

2300 Badger Drive  
Waukesha, WI 53188 USA