

600 A 25 kV class Cleer™ loadbreak connector system



General

Eaton's Cooper Power™ series Cleer™ loadbreak connector system is a 600 A loadbreak device rated for operation on 25 kV class systems. It is used to provide a visible break and visible ground on 600 A network and distribution systems without having to remove 600 A terminations and move heavy cable. The Cleer Loadbreak Connector System is fully shielded, submersible and meets the applicable requirements of IEEE Std 386™ -2006 standard – "Separable Insulated Connector Systems".

Many configurations are possible with this connector system. Under normal operating conditions, the current path is through one of the 600 A loadbreak/deadbreak 2-position junctions (DLJ625), through the 600 A loadbreak "C" (LCN) connector and through the second 600 A loadbreak/deadbreak junction.

When isolating underground cable, with the system energized or de-energized, with or without rated load current, with the use of a clampstick, the LCN connector can be removed. A 600 A loadbreak protective cap (LPC625) can then be installed on the two exposed loadbreak interfaces. All bushings of the connector system are then insulated and deadfront. When a 600 A termination with a 200 A reducing tap plug is used on the IEEE Std 386™ -2006 standard 600 A 15/25 kV deadbreak interfaces of the junction, a direct conductor test can be performed. A Cleer grounding elbow can then be installed on the 600 A loadbreak interfaces providing a visible ground. It is then safe to perform work on the underground cable.

EATON

Powering Business Worldwide

Construction

The Cleer 600 A loadbreak connector system includes two loadbreak/ deadbreak junctions, each consisting of one of Eaton's Cooper Power series exclusive 600 A loadbreak interface and one IEEE Std 386™ -2006 standard 600 A deadbreak interface.

The 600 A loadbreak "C" (LCN) connector incorporates Eaton's Cooper Power series field proven POSI-BREAK™ technology, providing a layer of insulation over the conductive internal inserts and an insulative sleeve on the base of the probes. This results in increased strike distance greatly reducing the possibility of partial vacuum flashovers and providing superior switching performance and reliability.

Interchangeability

The IEEE Std 386™ -2006 standard 600 A deadbreak interfaces are interchangeable with 600 A terminations currently available from all other manufacturers that also comply with IEEE Std 386™ -2006 standard.

Installation

No special tools are required for installation.

The Cleer 600 A loadbreak connector system is available in both in-line and square configurations. It is designed to be mounted directly to a vault or manhole walls or inside an enclosure. The in-line junction assembly has an adjustable stainless steel bracket for mounting at various operating angles. 600 A, BOL-T™, T-OP™ II or BT-TAP™ cable terminations are assembled to the source and load side 600 A deadbreak bushings following the instructions provided in those kits. Using a clampstick, the loadbreak "C" connector (LCN) is assembled to the two center 600 A loadbreak interfaces to complete the current path. Refer to mounting dimensions on page 5 and installation instructions, Service Information, S600-100-1 for details.

Production tests

Tests are conducted in accordance with IEEE Std 386™ -2006 standard.

- ac 60 Hz 1 Minute Withstand
 - 40 kV
- Minimum Partial Discharge Extinction Voltage
 - 19 kV (3pc Sensitivity)

Tests are conducted in accordance with Eaton requirements.

- Physical Inspection
- Periodic Dissection
- Periodic Fluoroscopic Analysis

Ordering information

To order the 600 A, 25 kV Class Cleer loadbreak connector system, refer to Table 3.

Each complete 600 A, 25 kV Class Cleer loadbreak connector (LCN2DLJ625) assembly kit contains:

- (2) 600 A, 25 kV, loadbreak/deadbreak 2-position junctions
- (1) 600 A, 25 kV, loadbreak "C" connector
- (1) Stainless steel mounting bracket
- (1) Stainless steel hardware kit (in-line bracket only)
- (2) Ground lugs (#8 sol to 2/0 str.)
- Silicone lubricant
- Installation Instruction Sheet

Table 1. Voltage Ratings and Characteristics

Description	kV
Standard Voltage Class	25
Maximum Rating Phase-to-Phase	26.3
Maximum Rating Phase-to-Ground	15.2
ac 60 Hz 1 Minute Withstand	40
dc 15 Minute Withstand	78
BIL and Full Wave Crest	125
Minimum Partial Discharge Extinction Voltage	19

Voltage ratings and characteristics are in accordance with applicable IEEE Std 386™ -2006 standard requirements.

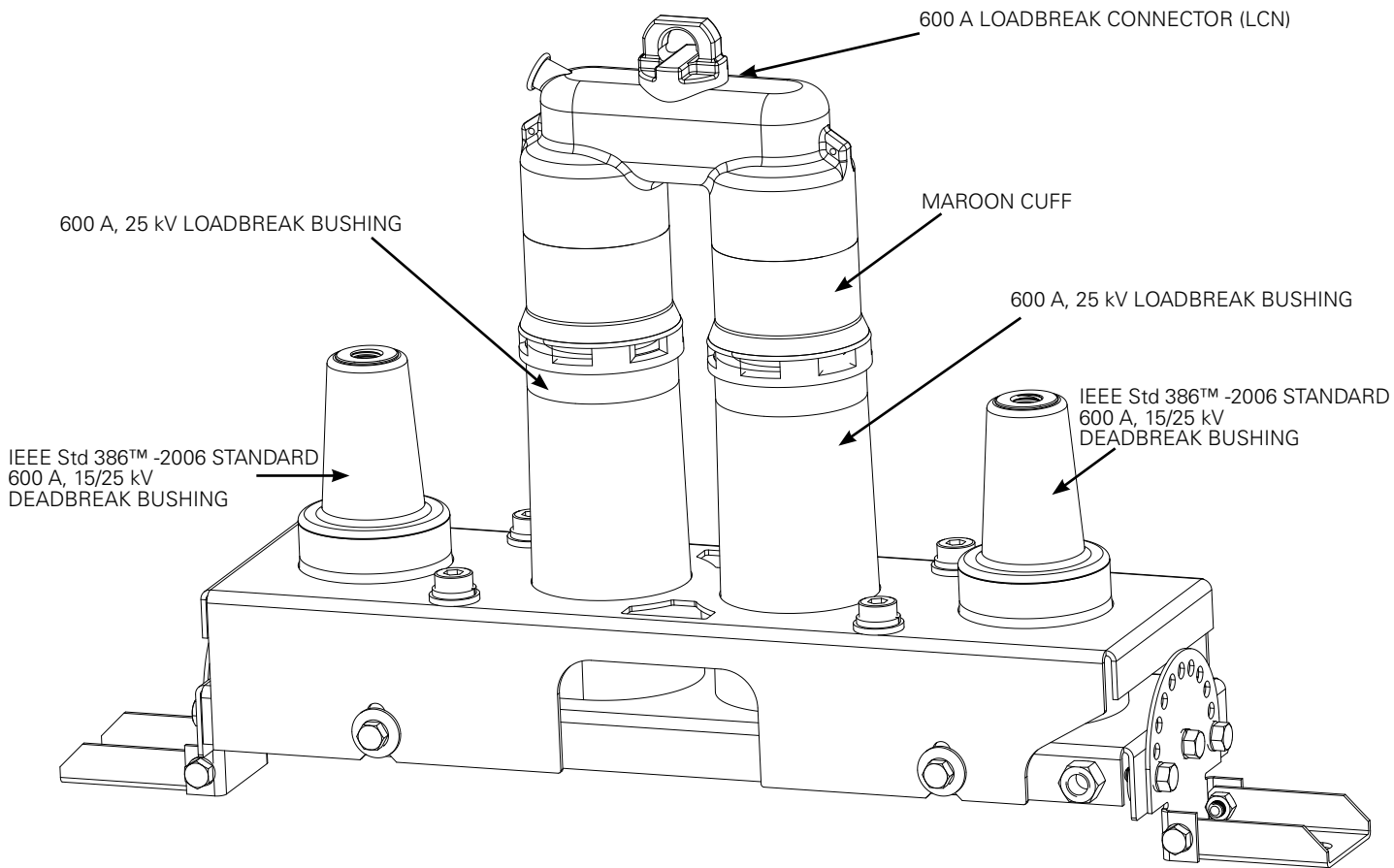

Figure 1. 600 A, 25 kV Cleer loadbreak connector system with in-line bracket.

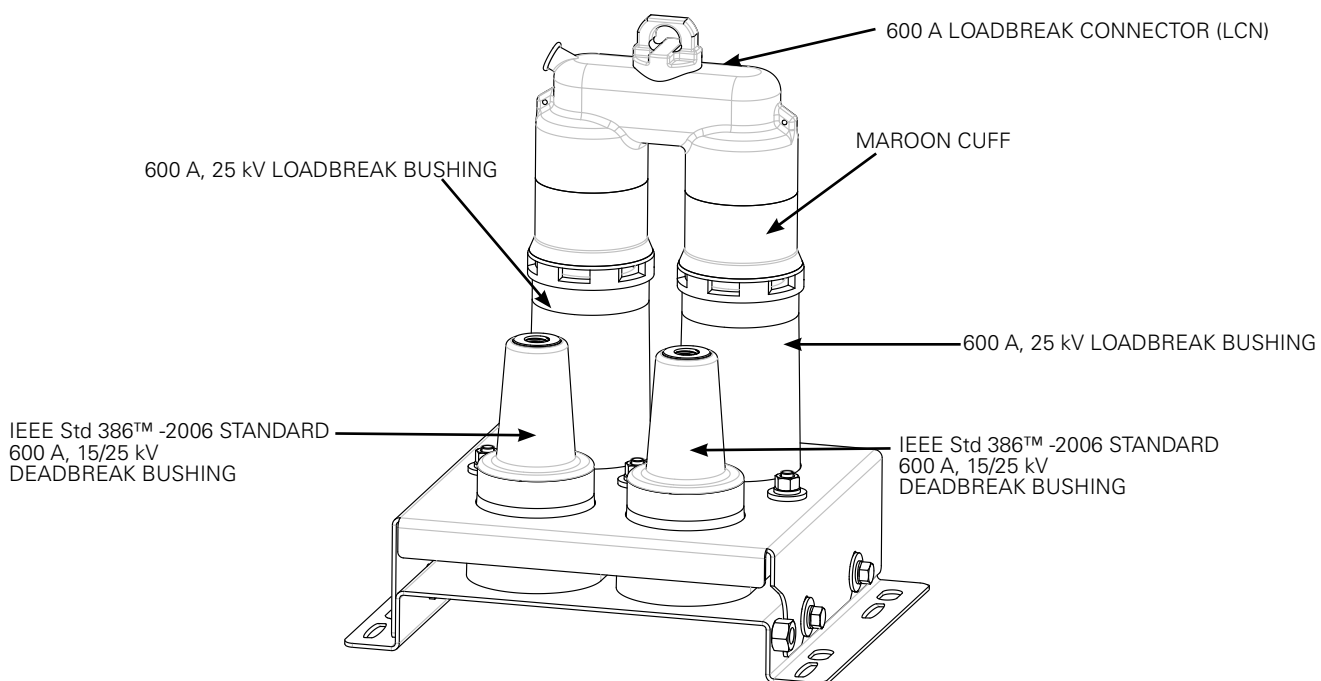

Figure 2. 600 A, 25 kV Cleer loadbreak connector system with square bracket.

Table 2. Current Ratings and Characteristics

Description	Amperes
600 A Loadbreak Interface	
Continuous Current	600 A rms
Loadbreak Switching	Five make and break operations at 600 A at 26.3 kV Phase-Phase
	One make and break operation at 900 A at 26.3 kV Phase-Phase
Fault Closure	10 kA rms symmetrical at 26.3 kV Phase-Phase after five 600 A loadbreak switching operations for 0.17 seconds
	10 kA rms symmetrical at 26.3 kV Phase-Phase after one 900 A loadbreak switching operation for 0.17 seconds
4 Hour Overload Current	900 A rms
Short Time Current (See Important below)	25 kA rms symmetrical for 0.17 seconds (limited by fault closure rating)*
	10 kA rms symmetrical for 3.0 seconds
IEEE Std 386™ -2006 standard 600 A, 15/25 kV Deadbreak Interface	
Continuous Current	600 A rms
4 Hour Overload Current	900 A rms
Short Time Current (See Important below)	25 kA rms symmetrical for 0.17 seconds*
	10 kA rms symmetrical for 3.0 seconds

Current ratings and characteristics are in accordance with applicable IEEE Std 386™-2006 standard requirements.

* 600 A loadbreak connectors are generally capable of short-time current ratings well in excess of those listed (25 kA to 40 kA ratings for 0.17s are typical). However, ratings are limited in Table 2 by the fault-closure rating. Contact your Eaton representative for maximum short-time current ratings if fault-closure operations are infeasible in your application.

Table 3. 600 A 25 kV Cleer Loadbreak Connector System

Description	Catalog Number
600 A, 25 kV Loadbreak Connector Assembly includes: two loadbreak/ deadbreak junctions with loadbreak "C" connector assembled in a In-Line SS. Bracket	LCN2DLJ625A2ILB
600 A, 25 kV Loadbreak Connector assembly includes: two loadbreak/ deadbreak junctions with loadbreak "C" connector assembled in a Square SS. Bracket	LCN2DLJ625A2SQB
600 A, 15 and 25 kV, Cleer Loadbreak Standoff Bushing (Parking Stand Mount)	PS625CLEER
600 A, 15 and 25 kV Cleer Loadbreak Standoff Bushing (Direct Wall Mount)	PS625CLEERDM
600 A, 25 kV Insulated Loadbreak Protective Cap	LPC625
600 A, 25 kV Loadbreak "C" Connector	LCN625

Accessories

Standoff bushing

Eaton meets the applicable requirements of IEEE Std 386™ -2006 standard - Separable Insulated Connector Systems with its 600 A, 15 and 25 kV Class Cleer loadbreak standoff bushing and provides double interfaces for temporarily parking the Cleer loadbreak connector in sectionalizing cabinets and in underground vaults. The standoff bushing is designed to be installed in the parking stand of the sectionalizing cabinet or in a parking stand mounted in a vault.



Figure 3. 600 A, 15 and 25 kV Cleer loadbreak standoff bushing.

Protective Cap

The 600 A, 25 kV Cleer loadbreak protective cap is an accessory device designed to electrically insulate and mechanically seal the 600 A Cleer loadbreak bushing interfaces.

Eaton incorporates its Cooper Power series field proven POSI-BREAK technology, providing a layer of insulation over the conductive internal insert and an insulative sleeve on the base of the probe. This results in increased strike distance greatly reducing the possibility of partial vacuum flashovers and providing superior switching performance and reliability.

The protective cap is fully shielded and submersible and meets the applicable requirements of IEEE Std 386™ -2006 standard. Refer to Installation Instruction Sheet, S600-100-2 for details.



Figure 4. 600 A, 25 kV Cleer loadbreak connector protective cap.

Grounding Elbow

The 600 A, 15/25 kV Class Cleer loadbreak grounding elbow (Figure 5) mates directly to the Cleer 600 A loadbreak interfaces providing a convenient means to ground after a visible break has been achieved. See Catalog Section 600-103 for details.



Figure 5. 600 A, 15 and 25 kV Cleer loadbreak grounding elbow.

Typical configurations

In-Line Bracket configurations

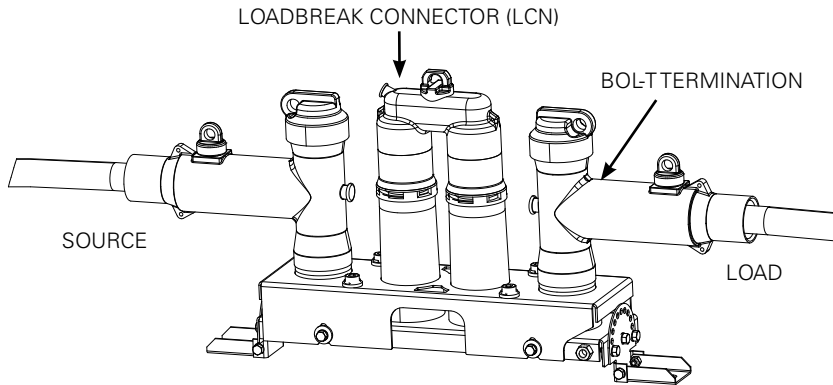

Figure 6. 600 A, 25 kV loadbreak connector system with (2) BOLT terminations.

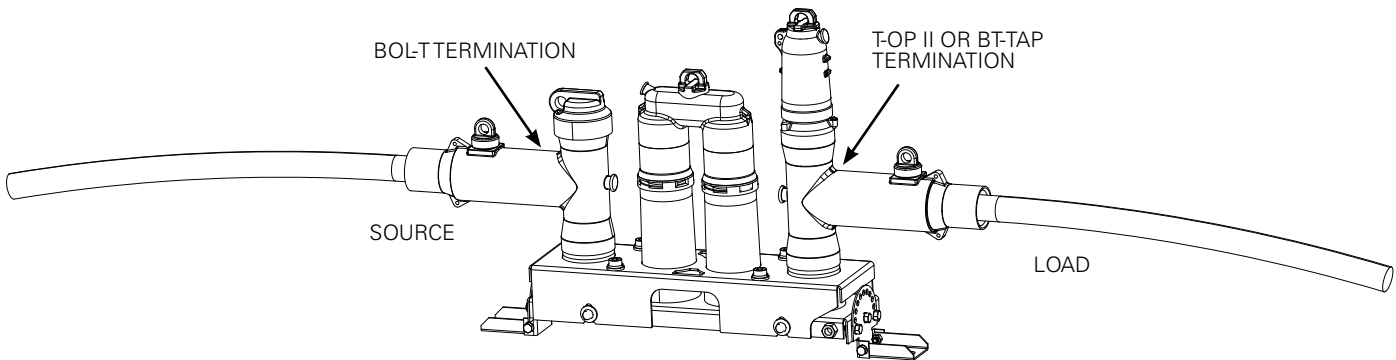

Figure 7. 600 A, 25 kV loadbreak connector system with (1) BOLT and (1) T-OP II or BT-TAP termination.

Square Bracket Configurations

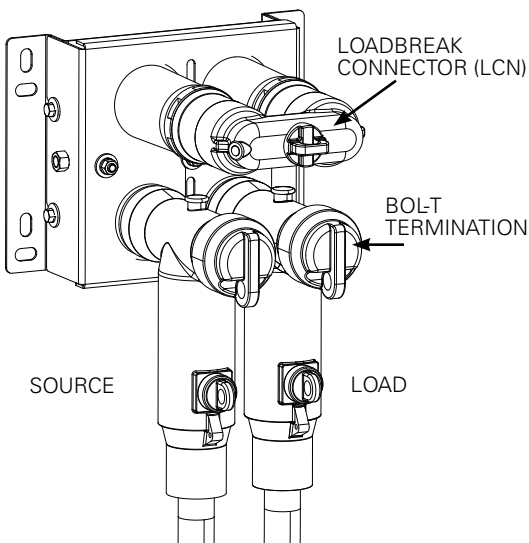

Figure 8. 600 A, 25 kV loadbreak connector system with (2) BOLT terminations.

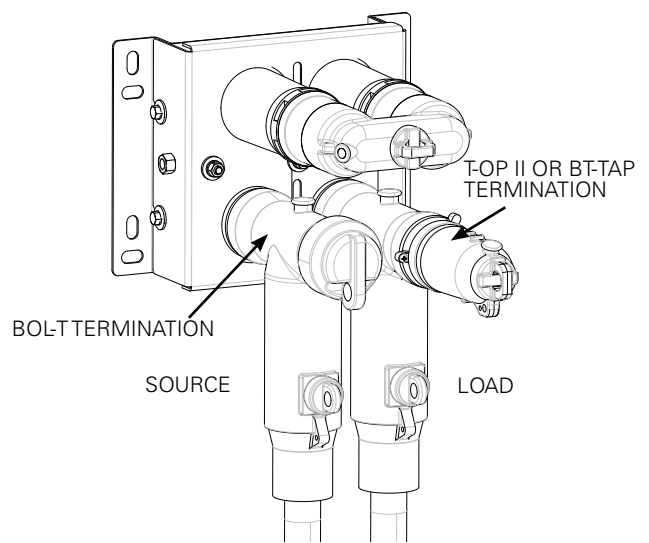

Figure 9. 600 A, 25 kV loadbreak connector system with (1) BOLT and (1) T-OP II or BT-TAP termination.

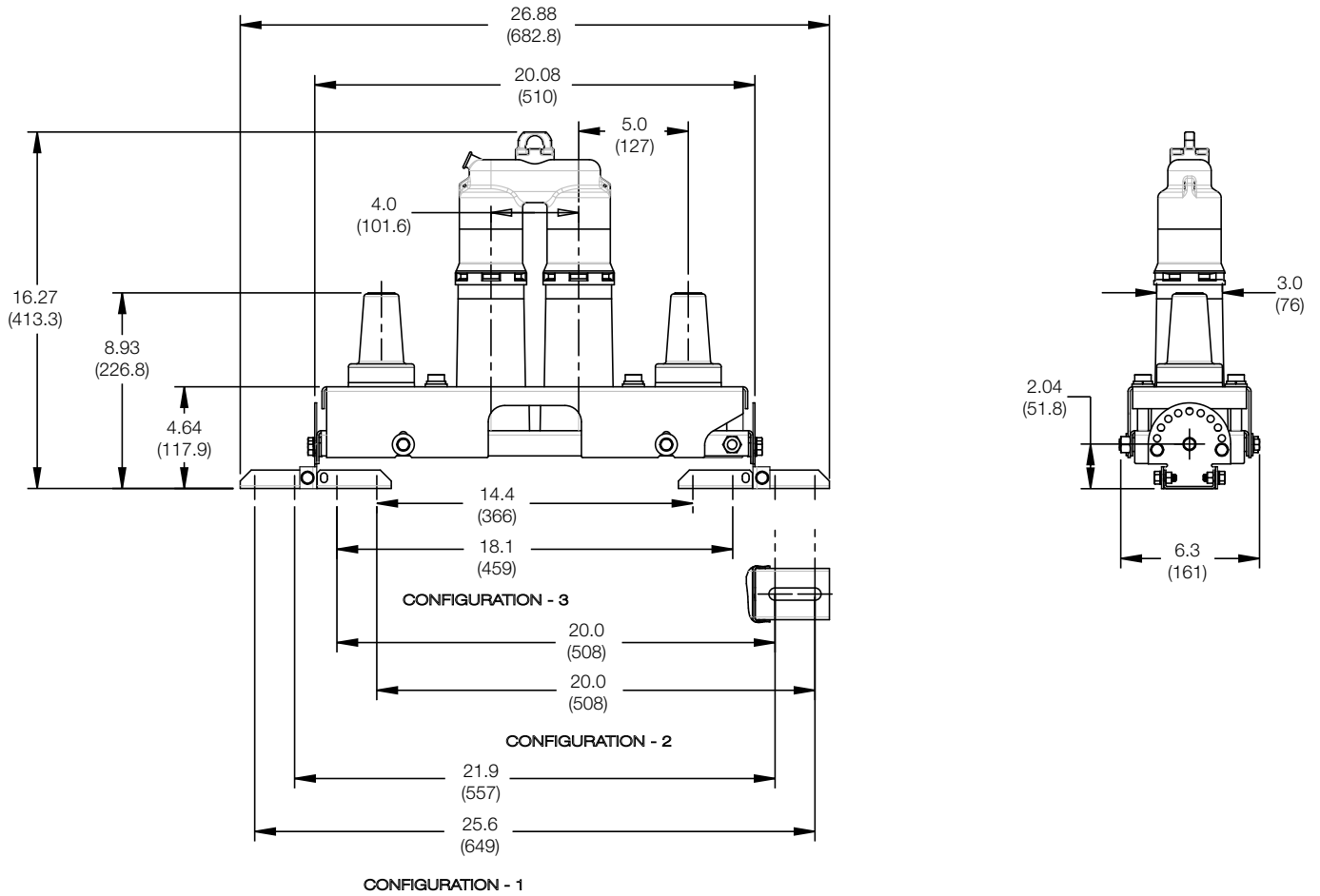

Figure 10. Dimensional drawing shows mounting configurations for in-line bracket.

Note: Dimensions given are for reference only.

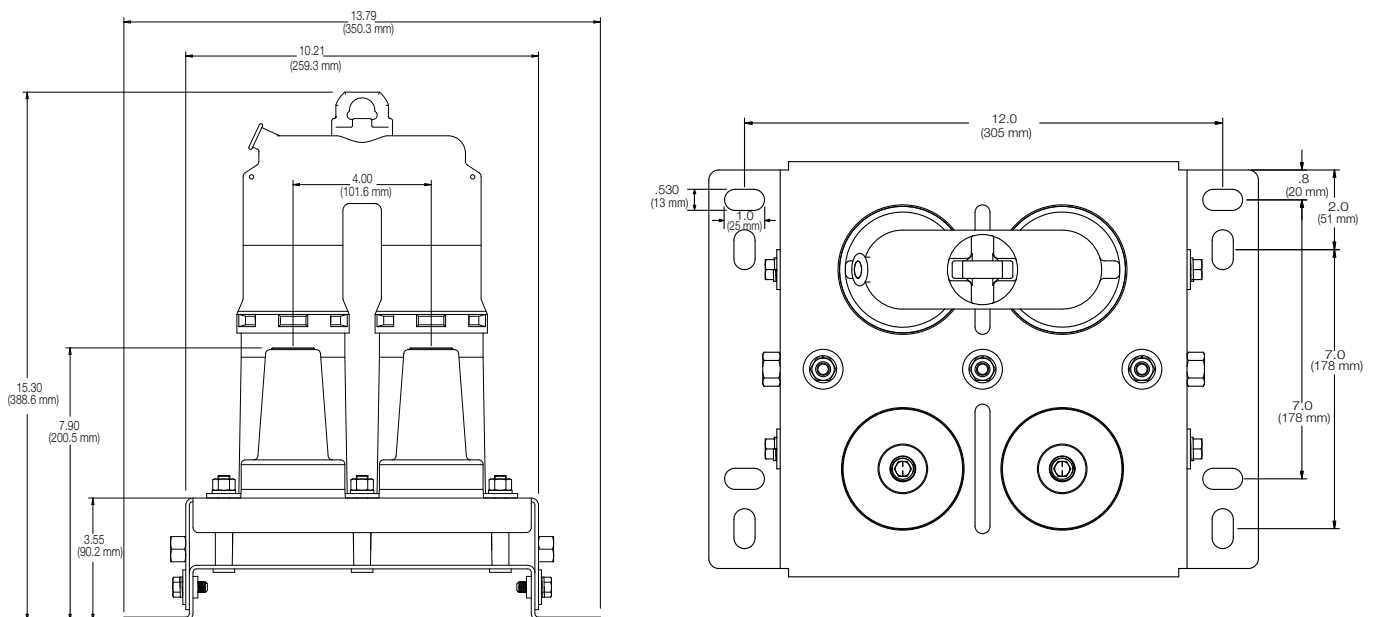

Figure 11. Dimensional drawing shows mounting configurations for square bracket.

Note: Dimensions given are for reference only.

Additional information

Refer to the following reference literature for application recommendations:

- CA650010EN**, 15 kV Class Cleer Loadbreak Connector System
- CA650012EN**, 28 kv Class Cleer Loadbreak Connector System
- CA650013EN**, 15 and 25 kV Class Cleer Grounding Elbow
- CA901002EN**, 600 A 15, 25, and 28 kV Class Cleer SecTER™ Cabinet
- S600-100-1**, 600 A 15, 25, and 28 kV Class Cleer Loadbreak Connector System Installation Instructions
- S600-100-2**, 600 A 15, 25, and 28 kV Class Cleer Loadbreak Connector Insulated Protective Cap Installation Instructions
- S600-100-3**, 600 A 15 and 25 kV Class Cleer Loadbreak Standoff Bushing Installation Instructions
- S600-103-1**, 600 A, 15 and 25 kV Class Cleer Grounding Elbow Installation Instructions
- CP1204**, 600 A 25 kV Class Cleer Loadbreak Separable Connector System Certified Test Report
- PA650002EN**, The Cleer Solution for Distribution Systems

Eaton
1000 Eaton Boulevard
Cleveland, OH 44122
United States
Eaton.com

Eaton's Cooper Power Systems Division
2300 Badger Drive
Waukesha, WI 53188
United States
Cooperpower.com

© 2015 Eaton
All Rights Reserved
Printed in USA
Publication No. CA650011EN

Eaton, Cooper Power, Cleer, BOLT, TOP, POSI-BREAK, and BT-TAP are valuable trademarks of Eaton in the U.S. and other countries. You are not permitted to use these trademarks without the prior written consent of Eaton.
IEEE Std 386™ -2006 standard is a trademark of the Institute of Electrical and Electronics Engineers, Inc., (IEEE). This publication/product is not endorsed or approved by the IEEE.

For Eaton's Cooper Power series Cleer loadbreak connector system information call 1-877-277-4636 or visit: www.cooperpower.com.