

250 A 25 kV class deadbreak elbow connector - interface A



DE250 - 24 kV Applications

Related products

- DRC250 Receptacle Cap
- DPD250 Dead End Plug
- DPS250 Standoff Plug
- DPE250 Earthing Plug
- DJ250 Junctions

Installation

- No special tools, heating, taping, or potting are required
- Connector may be energized immediately after installation on its mating part
- Mates with bushings, plugs, and junction devices designed for interface A and complying with the listed standards

Application

- For connection of polymeric cable to transformers, switchgear, motors and other equipment with a premoulded separable connector
- For indoor and outdoor installations
- Type A interface as described by CENELEC EN 50180 and EN 50181
- System voltage up to 24 kV
- Continuous current 250 A (300 A overload for 8 hours)
- Cable particulars:
 - Polymeric cable (XLPE, EPR, etc.)
 - Copper or aluminum conductors
 - Semiconducting or metallic screens
- Conductor size 16-120 mm²

Features

- Provides a fully screened and fully submersible separable connection when mated with the proper bushing or plug
- Built-in capacitive test point to determine the circuit status or install a fault indicator
- No minimum phase clearance requirements
- Mounting can be vertical, horizontal, or any angle in between
- 100% factory tested
 - AC withstand
 - Partial discharge

Standards

- Meets the requirements of Cenelec HD629.1 and IEC 60502-4

EATON

Powering Business Worldwide

Quality assurance

- Our manufacturing facility is registered to ISO 9001 by third party audit
- Required Production Tests
- Periodic X-Ray Analysis

Packaging

- Supplied in a kit with parts listed below, approximate weight 1 kg

Kit contents:

- Elbow Housing
- Conductor Contact
- Pin Contact
- Bail Assembly
- Hex Key

The kit also includes lubricant and installation instructions.

Table 1. Electrical Ratings

Maximum System Voltage (U_m)	24 kV
Impulse	125 kV
AC Withstand (5 min.)	54 kV
Continuous Current	250 A
Overload (8 hrs Max.)	300 A
Short Circuit Withstand, 1 sec. (rms sym.)	12.5 kA

Features and detailed description

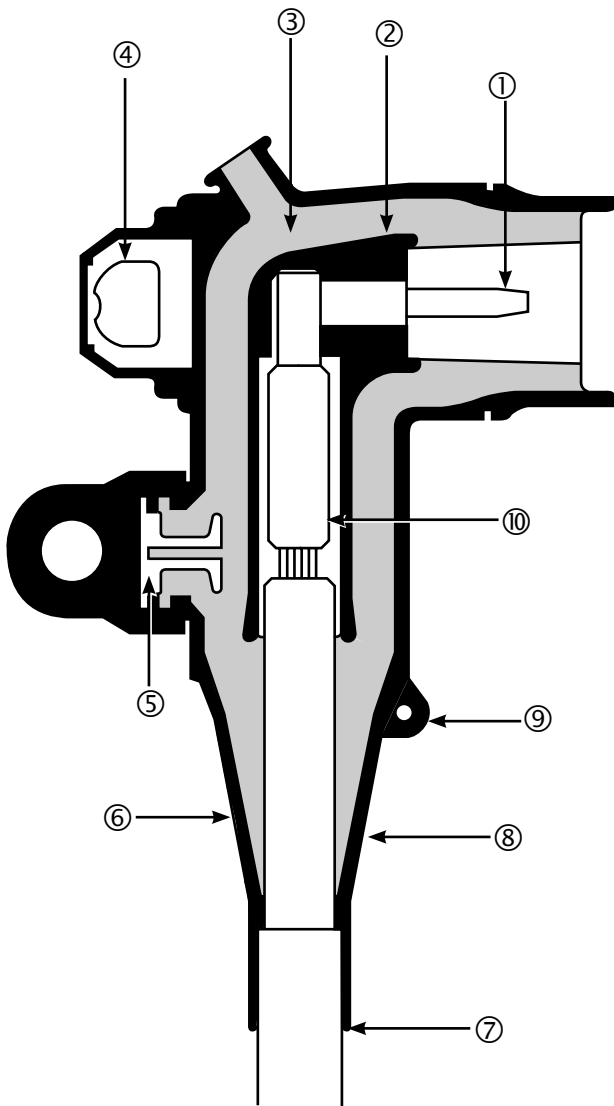

1. Pin Contact

Tin-plated copper pin screws into the conductor connector with the supplied hex key.

2. Internal Screen

Moulded EPDM conducting rubber screen controls electrical stress.

3. Insulation

Moulded EPDM insulating rubber is formulated and mixed in-house to ensure high quality.

4. Pulling Eye

Encapsulated stainless steel pulling eye with a detent to position the bail.

5. Capacitive Test Point

Capacitive test point provides means to check circuit status. A moulded EPDM conducting rubber cap provides a watertight seal.

6. Stress Relief

The configuration of the outer screen and insulation provides cable stress relief.

7. Cable Entrance

The sized opening provides an interference fit to maintain a watertight seal.

8. External Screen

Moulded EPDM conducting rubber mates with the cable screen to maintain screen continuity and ensure that the assembly is at earth potential.

9. Earthing Eye

Moulded into the external screen for connection of an earthing wire.

10. Conductor Contact

Inertia welded bimetallic compression connector accepts copper or aluminum conductors.

11. Stainless Steel Bail (Figure 2 or 3)

Secures the connector to its mating bushing or accessory.

Figure 1. 250 A, 24 kV Class DE250 deadbreak elbow connector.

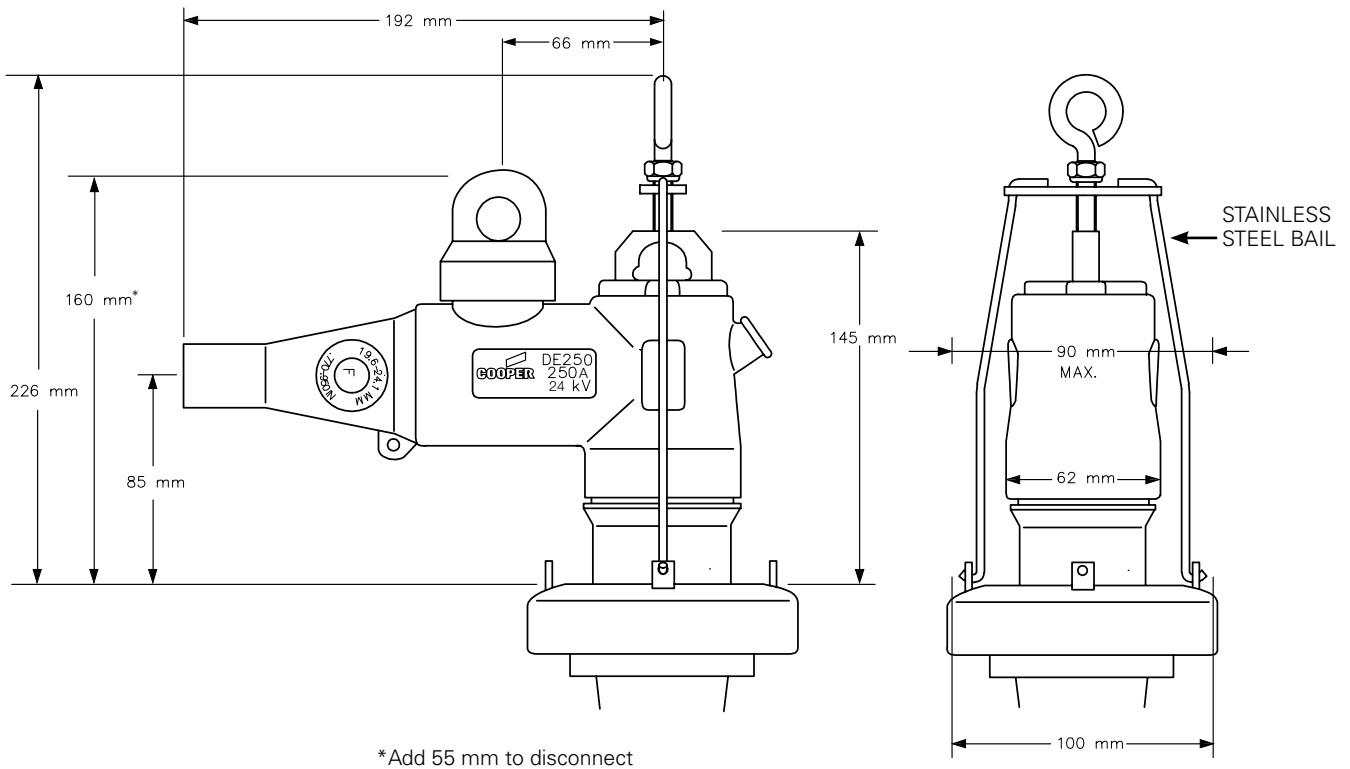

Figure 2. DE250 deadbreak elbow connector dimensional information.

Ordering information

The standard kit is packaged individually in a carton with elbow housing, conductor contact, pin contact, bail assembly and other necessary parts to complete the installation. Cable sealing kits must be ordered separately.

Step 1

Select the insulation diameter code which best centers the insulation diameter of the cable from Table 2.

Step 2

Identify the conductor size and determine the desired connector type from Table 3.

Step 3

Change the "0" in DE250 to a "1", if a Spring Loaded Bail is required. See Figure 3.

Ordering Example:

For 1 20 kV cable with a 50 mm² aluminum conductor, 21.0 mm core insulation diameter, unplated DIN connector and a standard bail, specify **DE250F50**.

Note: Bimetallic connectors can be used with aluminum or copper conductors.

Table 3. Conductor Code

Stranded Conductor Size (mm ²)	DIN Unplated	EDF Type
16	16	E16
25	25	E25
35	35	E35
50	50	E50
70	70	E70
95	95	E95
120	120	-

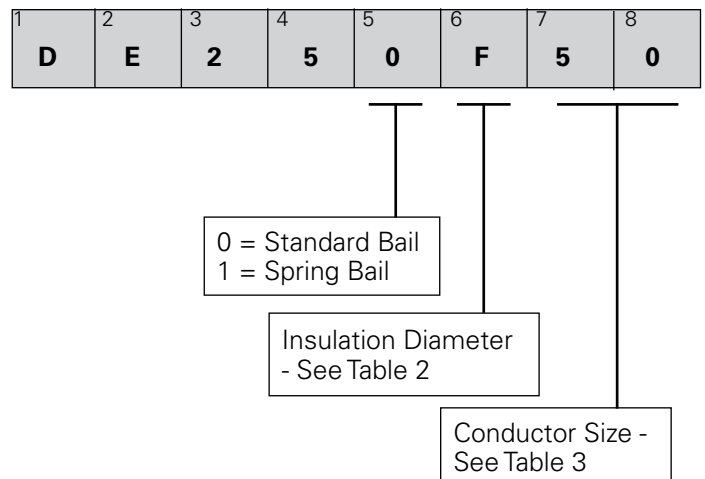

Table 2. Cable Insulation Range

Insulation Range Designation	Cable Insulation Range Ø (mm)	
	Min.	Max.
B	13.5	17.4
D	16.3	20.8
F	19.6	24.1
H	23.1	28.7
J	27.9	33.5

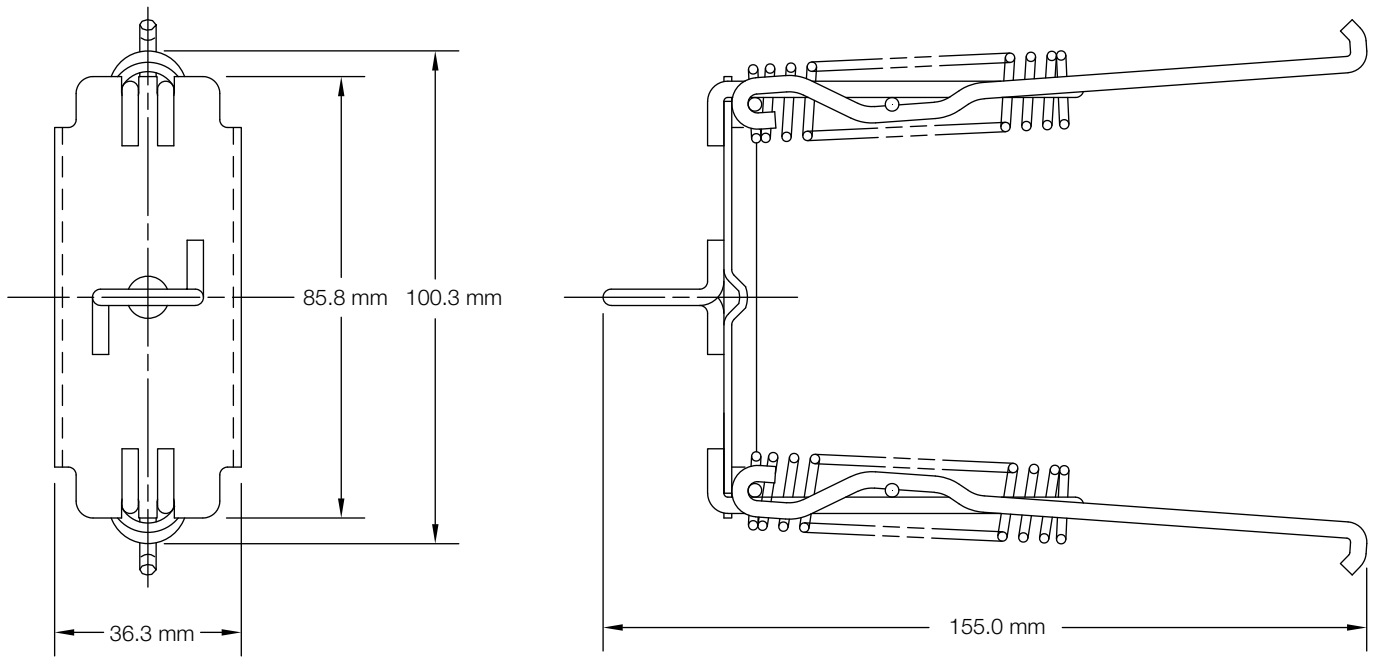

Figure 3. Optional spring loaded bail.

Eaton
1000 Eaton Boulevard
Cleveland, OH 44122
United States
Eaton.com

Eaton's Cooper Power Systems Division
2300 Badger Drive
Waukesha, WI 53188
Eaton.com/cooperpowerseries

© 2016 Eaton
All Rights Reserved
Printed in USA
Publication No. CA650036EN

Eaton is a registered trademark.

All other trademarks are property
of their respective owners.