

# Fault Indicators

Electrical Apparatus

## S.T.A.R.™ Faulted Circuit Indicators Programmable Delayed Reset Type (SDOH)

320-95

### DESCRIPTION

Cooper Power Systems S.T.A.R.™ Programmable Delayed Reset faulted circuit indicators are designed to quickly and easily locate faulted sections of overhead systems. This faulted circuit indicator (FCI) is designed for use on overhead bare conductors. A long-life Lithium Ion battery provides power to indicate the faulted conditions using two highly visible LED indicators. The unit is capable of being programmed with any one of five delay times. This FCI can also be quickly reset using the optional manual testing/reset tool (SMRT), and programmed to indicate a temporary fault when required. FCIs provide a reliable means of fault location and isolation. They also eliminate fault chasing methods that are costly and time consuming, and very stressful on system components exposed to fault currents. The SDOH FCI is ideally suited for temporary use as a testing tool or permanent overhead installation. The temporary fault detection feature also allows the unit to be used to detect general fault location in applications where an intermittent fault causes recloser operation.

### CONSTRUCTION

SDOH FCIs consist of a sensor unit with an integral dual LED indicator powered by a Lithium Ion battery. Rugged solid-state construction ensures dependability and accuracy. Installation can be achieved on a wide range of cable diameters with a single hot stick. The sensor unit itself features a clamping mechanism design that allows easy snap-on connection to the live conductor with the use of a single hotstick.



Figure 1.  
S.T.A.R. Programmable Delayed Reset (SDOH) faulted circuit indicator.

### TRIP RATING

The SDOH FCI is equipped with self adjusting trip that features a load sensing design. This FCI automatically adjusts the trip rating based on the average load current it reads at the location.

### DESIGN FEATURES

The SDOH FCI automatically resets back to the normal indication when the programmed reset time has expired. The unit can be field programmed with delay times of 2-hour, 4-hour (factory default), 8-hour, 24-hour or manual reset.

The SDOH FCI is constructed using tough, durable, corrosion-proof, submersible materials.

The Lithium Ion battery has a ten (10) year shelf life and provides a minimum 500 hours of flashing time for the high intensity LED indicator. This is enough for 125 fault events when using 4-hour delay time.

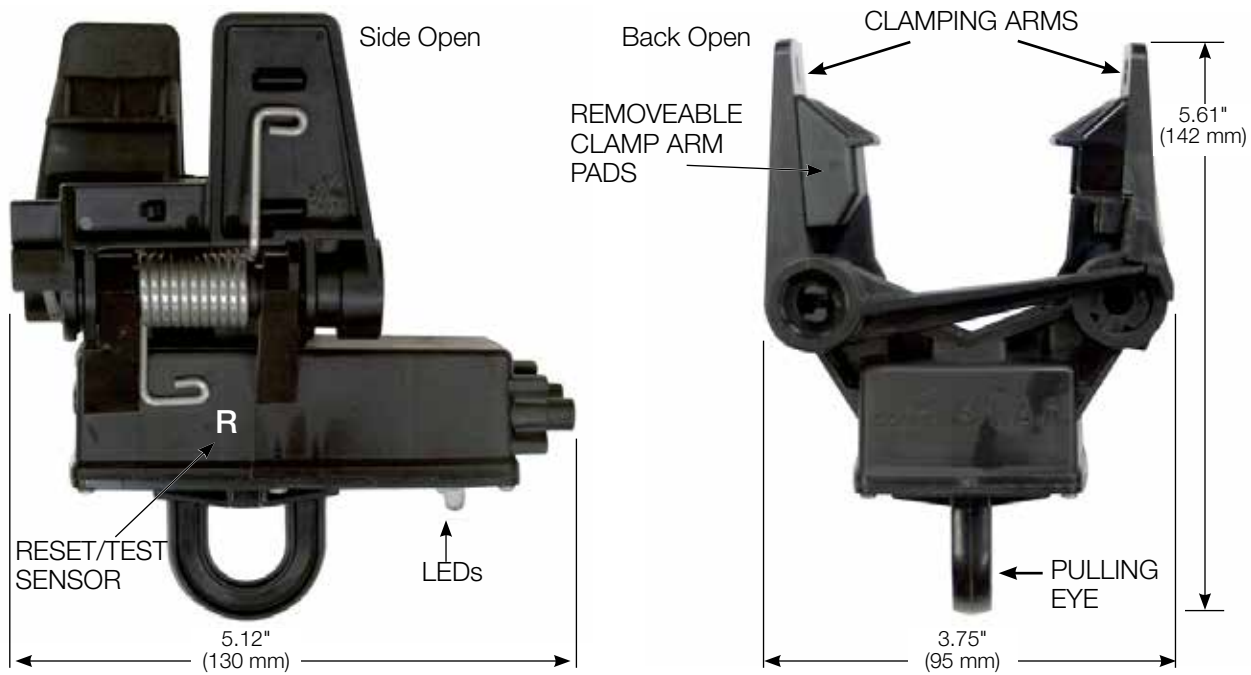

Figure 2. Features and dimensions of a SDOH faulted circuit indicator (shown in the “armed” position).

## TESTING

S.T.A.R. faulted circuit indicators are made of corrosion resistant materials and meet or exceed IEEE Std 495™-1986 standard “Guide for testing Faulted Circuit Indicators”.

100% automated production testing verifies the trip rating and the reset time.

The electronic components are completely encapsulated to prevent any environmental damage.

## INSTALLATION

Installation is quick and easy. No special tools are required. The patented clamping mechanism of the sensor provides for easy installation on an energized system using a single hotstick.

Testing and setting the SDOH FCI can be done by touching the reset tool (catalog number SMRT) to the side of fault indicator marked by “R”. See Table 2 for programming directions.

TABLE 1  
Electrical Ratings and Characteristics

Description	Ratings and Characteristics
Catalog Number	SDOH
Power Requirements	1.2 AH Lithium Ion Battery (non-replaceable)
Reset Time	Field Configurable 2, 4 (default), 8, 24 Hours or manual reset
Trip Current	Self-Adjusting, 175 A Min, 800 A Max.
Mode of Indication	Dual LEDs
Min Operating Voltage	5.0 kV
Max Operating Voltage	69 kV L-L
Fault Withstand Capability	25 kA for 10 Cycles per IEEE Std 495™ -1986 standard
Temperature Range	-40 degrees C to +85 degrees C
Materials	Corrosion-resistant & submersible per IEEE Std 495™-1986 standard
Weight	13.3 ounces (.38 kg)

The unit is manually reset by touching the upper left corner marked “R” with the reset tool for two (2) seconds. Upon manual reset, the unit will “flash back” the number corresponding to reset hours to which the FCI has been set. See Table 2 for how many flashes correspond to each reset time. The reset procedure also provides positive indication of battery operation. In the case of a low battery, upon reset LEDs will flash yellow corresponding to the current reset time.

Refer to service information S320-95-1 for more information.

## OPTIONS

### Testing/Reset Tool

The manual testing/reset tool can be ordered using catalog number SMRT.

## PROGRAMMING INFORMATION

To put the SDOH FCI into program mode, hold the SMRT tool near "R" on side of FCI until one yellow flash appears (approximately ten (10) seconds) then remove. The FCI will flash back current reset time corresponding to Table 2.

To change the reset time once the SDOH FCI is in program mode, hold the SMRT tool until the next reset time has flashed then remove. When in program mode, holding the reset tool over "R" will increment the reset time and respond by flashing confirmation corresponding to Table 2.

For complete programming, installation, testing and resetting instructions, please refer to our *Service Information, S320-95-1 S.T.A.R. Faulted Circuit Indicator Programmable Delayed Reset Type SDOH Installation Instructions*.

## ORDERING INFORMATION

To order a S.T.A.R. Faulted Circuit Indicator Programmable Delayed Reset Type SDOH, see Table 3.

## ADDITIONAL INFORMATION

Refer to the following literature for more information.

- S320-95-1, S.T.A.R. Faulted Circuit Indicator Programmable Delayed Reset Type SDOH Installation Instructions
- B320-03014 Overhead Fault Indication Made Easy with S.T.A.R., Programmable Delayed Reset Overhead Type Faulted Circuit Indicators
- B320-03013, Cost Effective Tools for Finding the Fault Faster and Reducing Outage Duration

**TABLE 2**  
Reset Times

FCI Reset Time	Program Confirmation (LEDs Flash Back)
2-hour	1 time (green)
4-hour (factory default)	2 times (green)
8-hour	3 times (green)
24-hour	4 times (green)
Manual Reset	2 times (red)

**Note:** Once desired reset time is reached, wait ten (10) seconds, remove the tool and the FCI will flash back the set time confirmation three (3) times, then rapid green /red indicating the unit is ready for installation.

**TABLE 3**  
SDOH FCI Ordering Information

Description	Catalog Number
FCI	SDOH
Reset Tool	SMRT

© 2012 Cooper Industries. All Rights Reserved.  
Cooper Power Systems and S.T.A.R. are a valuable trademarks of  
Cooper Industries in the U.S. and other countries. You are not  
permitted to use the Cooper Trademarks without the prior written  
consent of Cooper Industries.

One Cooper | [www.cooperpower.com](http://www.cooperpower.com) | Online



2300 Badger Drive  
Waukesha, WI 53188