

Cable Accessories – Cable Fixtures

Cable Clamps



Specifications

- Material: Polyamide, Glass-Fibre Reinforced
- Colour: Black
- Tensile strength: 120 N/mm²
- Flexural strength: 200 N/mm²
- Thermal expansion: 0.02 % / 1 °C
- Thermal limits: -40 °C to 120 °C long term
220 °C short term
- Fire resistance: UL94 – VO
VDE 0304, Part 3, Class 1a
- Resistant to: U.V. light, Ozone, Oils, Fuels, Alkalis

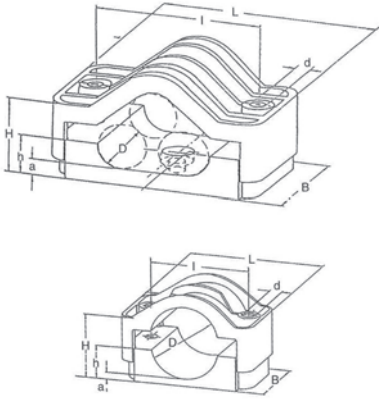

PART NO.	CABLE DIAMETER mm	NO. OF CABLES	DIMENSIONS mm					WEIGHT g
			L	B	l	ød	H	
CC26-38	26 – 38	1	92	60	60	12.4	32 – 44	110
CC36-52	36 – 52	1	108	60	75	12.4	40 – 57	170
CC33-46	33 - 46	3	170	80	130	12.4	53 - 75	430
CC44-50	44-50	3	170	80	130	12.4	75-100	550