

# Cable support solutions

Cable ladder, tray, and supports



Eaton and Cooper united.

Energizing a world  
that demands more.

Discover today's Eaton.

### Powering business worldwide

As a global diversified power management company, we help customers worldwide manage the power needed for buildings, aircraft, trucks, cars, machinery and businesses.

Eaton's innovative technologies help customers manage electrical, hydraulic and mechanical power more reliably, efficiently, safely and sustainably.

**EATON**

*Powering Business Worldwide*



## We deliver:

- **Electrical solutions** that use less energy, improve power reliability and make the places we live and work safer and more comfortable
- **Hydraulic and electrical solutions** that enable machines to deliver more productivity without wasting power
- **Aerospace solutions** that make aircraft lighter, safer and less costly to operate, and help airports operate more efficiently
- **Vehicle drivetrain and powertrain solutions** that deliver more power to cars, trucks and buses, while reducing fuel consumption and emissions

We provide integrated solutions that help make energy, in all its forms, more practical and accessible.

With 2012 sales of \$16.3 billion, Eaton has approximately 103,000 employees around the world and sells products in more than 175 countries.



## Eaton's electrical business

### Eaton is a global leader with expertise in:

- Power distribution and circuit protection
- Backup power protection
- Solutions for harsh and hazardous environments
- Lighting and security
- Structural solutions and wiring devices
- Control and automation
- Engineering services

Eaton is positioned through its global solutions to answer today's most critical electrical power management challenges. With 100 years of electrical experience behind us, we're energized by the challenge of powering up a world that demands twice as much energy as today. We're anticipating needs, engineering products, and creating solutions to energize our markets today and in the future.

We are dedicated to ensuring that reliable, efficient and safe power is available when it's needed most.

[Eaton.com](http://Eaton.com)

CoSPEC, the Specifier Center, is designed to help you easily SELECT, VIEW and DOWNLOAD B-Line product design content in any one of nearly one hundred non-proprietary and proprietary CAD, BIM, PDMS, and graphics formats, which helps speed the integration of the content into your design project.

## Features

- Easy integration and configuration
- Comprehensive library of 2D drawings and 3D models for CAD, BIM, PDMS, SP3D, and graphics output
- The most up to date software versions and product data information are always available
- Submittals and specification sheets in PDF format
- Proprietary file format outputs are native to the chosen software

## Nearly a Hundred Download Options

- Aveva PDMS and Intergraph SmartPlant SP3D (on select products) content
- Autodesk Revit output available
- Proprietary formats from AutoCAD to SolidWorks to Catia
- Non-proprietary formats like DXF, STEP, and more
- Graphics files in a number of formats including EPS

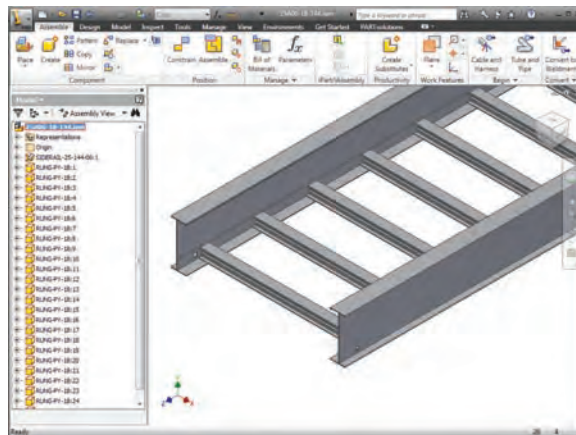

To get started planning your next project, visit [www.cooperblineline.com/CoSPEC](http://www.cooperblineline.com/CoSPEC)

## Select



## View



## Download

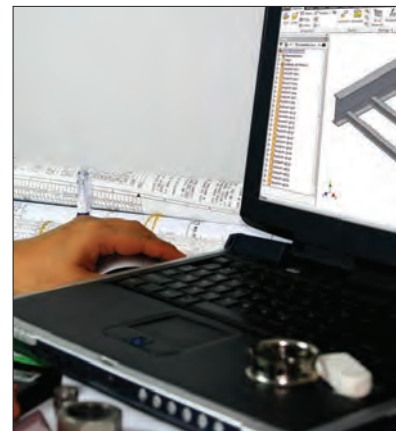

## 2D Native

- Allplan 2008
- AutoCAD >=V14
- Cadkey CDL >=V19
- Catia IUA - V4
- HP ME 10 >=V9
- Medusa >=2000i
- Microstation (DGN) >=V8
- SolidEdge >=V17
- VX (Varimetrix) >=V5.0

## 2D Neutral & Graphics

- BMP (2D & 3D View)
- DWF-ASCII 5.5, Binary 5.5 and Compressed 5.5
- DWG >=V14
- DXF-V12\HPGL-V2
- IGES >=V5.0
- JPEG (2D & 3D Views)
- Metafile 2D-V1, & PS2-V2
- MI >=V8
- PDF Datasheet
- Postscript EPS
- SVG
- TIFF (2D & 3D View)

## 3D Native

- Autodesk 3D Studio MAX
- Allplan = 2008
- AutoCAD >=V14
- AVEVA PDMS/Marine (Equipment Spec)
- Caddy++ via SAT-V4.2
- Catis >=V5 R8 and IUA-V4
- EMS
- Google SketchUp
- Autodesk Inventor >=R5.3, R10, R11
- Mechanical Desktop >=V5
- Nupas/Cadmatic
- One Space Modeling >=2007
- Pro/E Wildfire >=I
- PRO-Desktop
- Autodesk Revit >= 2009\* (coming soon)
- SolidEdge >=V17
- SolidWorks >=2001+
- Think3 >=2006.2
- Tribon M3
- Unigraphics >=NX3
- VX (Varimetrix) >=V5

## 3D Neutral

- CIP
- DWG >=V14
- DXF V14
- IGES
- JT
- Metafile 3D (PS3)-V2
- Parasolid-Binary V15 and Text V15
- PDF 3D-7.01
- SAT - V2.0 through V6.0
- STEP-AP203, AP215a & AP214b
- STL
- U3D (Universal 3D)
- VRML >=V1.0
- XGL

To get started, visit [www.cooperblineline.com/CoSPEC](http://www.cooperblineline.com/CoSPEC)

# Introduction

---

## About Eaton's B-Line Business

Eaton's B-Line Business is a global provider of innovative, labor-saving cable management systems, support systems, and enclosure solutions for engineered facility subsystem applications. With a full range of cable support solutions, we offer one of the lowest lifetime cost of ownership.

We are dedicated to servicing our global customer base with manufacturing and technical expertise. Our manufacturing facilities are located in South Korea, Malaysia, Kingdom of Saudi Arabia, United States of America, and Canada. In addition, we offer best-in-class specification engineering services, which provide pre- and post-sale engineering and technical support.











Eaton's B-Line Manufacturing Locations



Approvals for products may include (varies by product type):



# Table of Contents

<b>CoSPEC™</b> .....	1 - 2	
<b>Introduction</b> .....	3	
<b>Structural Steel Savings</b> .....	5 - 10	
<b>Cable Ladder Construction Guide</b> .....	11	
<b>Cable Tray Construction Guide</b> .....	12	
<b>Cable Ladder Construction</b> .....	13 - 15	
<b>Straight Section Cable Ladders &amp; Covers</b>		
High Performance Ladder (HPL) Series .....	17	
Standard Duty Ladder (SDL) & Heavy Duty Ladder (HDL) Series .....	18	
Cable Ladder Covers & Accessories .....	19 - 20	
<b>Cable Ladder Fittings &amp; Fitting Covers</b>		
Horizontal Bends .....	23 - 24	
Horizontal Tees & Crosses .....	25	
Vertical Inside & Outside Bends .....	26 - 27	
Vertical Tees .....	28	
Cable Support Fittings .....	29	
Reducers .....	31	
Horizontal Expanding & Reducing Tees & Crosses .....	32 - 34	
Cable Ladder Fitting Covers .....	35	
<b>Cable Ladder Accessories</b>		
Splice Plates, Blind Ends, Drop-Outs, Dividers, Guides, Clamps, Earth Continuity Connectors, Threaded Rods .....	37 - 41	
<b>Cable Ladder Technical Guide</b> .....	42 - 52	
<b>Perforated &amp; Solid Bottom Cable Tray</b>		
<b>Northern Asia</b>		
Straight Sections .....	55 - 58	
Splice Plates & Cover Clamps .....	59 - 61	
Hold Downs & Hardware .....	62	
Fittings .....	63 - 74	
Covers .....	75 - 78	
<b>Southern Asia</b>		
Straight Sections .....	81 - 84	
Splice Plates .....	85 - 86	
Cover Clamps, Hold Downs & Hardware .....	87 - 88	
Fittings .....	89 - 100	
Covers .....	101 - 104	
<b>Cable Cleats</b>		
Cable Cleats .....	105 - 109	
<b>Strut Systems</b>		
Introduction & Technical Data .....	112 - 119	
Channels .....	120 - 124	
Hardware .....	125 - 128	
Fittings .....	129 - 132	
<b>Index</b> .....	133 - 139	

## NOTICE

Eaton's B-Line Business reserves the right to change the specifications, materials, equipment, prices or the availability of products at any time without prior notice. While every effort has been made to assure the accuracy of information contained in this catalog at the time of publication, B-Line is not responsible for inaccuracies resulting from undetected errors or omissions.

# Structural Steel Savings

## Reduce Structural Steel Supports

With B-Line cable ladder systems, you can reduce the number of structural steel supports by as much as 66%, all while meeting or exceeding global industry standards.

### Resources

By visiting <http://www.cooperblineline.com/sss>, you can access our library of resources available that demonstrate the ways a B-Line cable ladder system can help reduce engineering complexity and costs. These resources include:

- **Video:** Five minute video showing our key features and support recommendations
- **Support recommendations:** Submittal drawings showing where supports are recommended to be placed
- **Test reports:** Detailed reports highlighting our products' load testing performance in our engineering laboratories
- **Calculator:** A cost savings calculator that estimates potential savings based on user-entered variables

### For Steel & Aluminum Cable Ladder

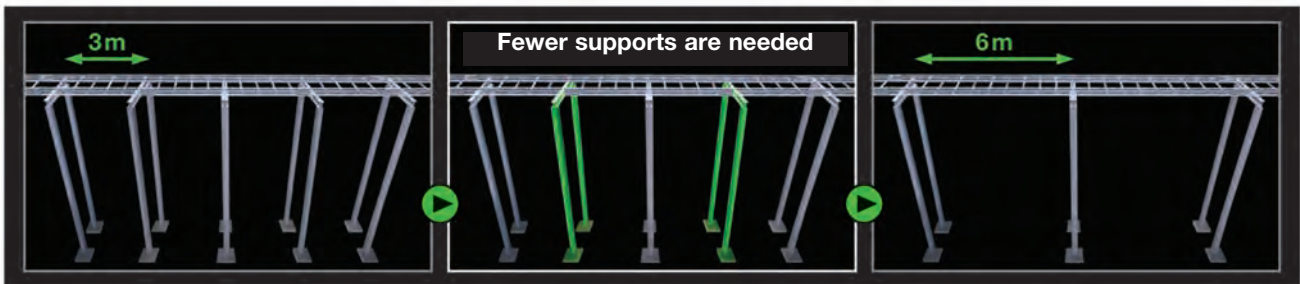

### For Aluminum Cable Ladder

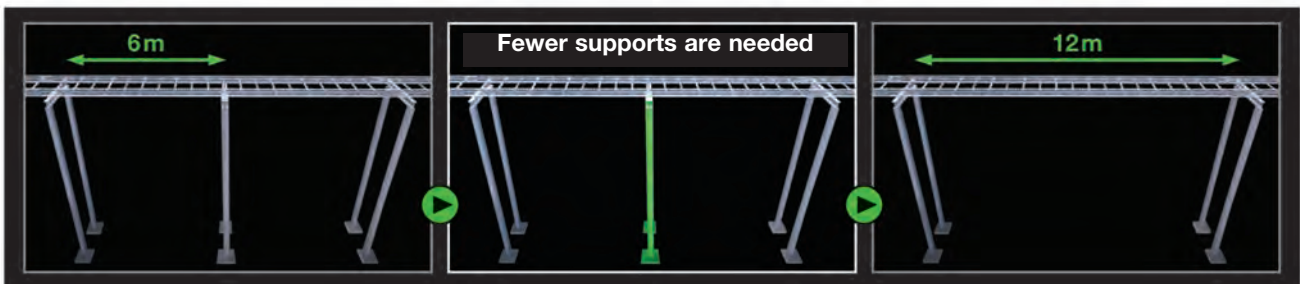

## 5 Key Product Attributes

### I-Beam Side-Rail Design

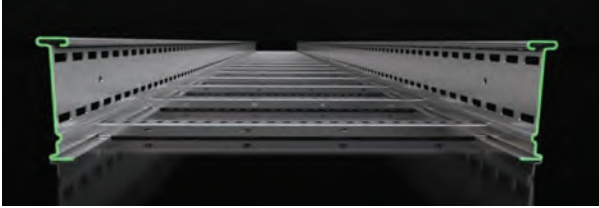

- Maximizes stiffness
- Offers positive rung support
- Enhances clamping options
- Carries load on longer spans, reducing support requirements

I-Beam Design Can Carry up to 2.3 Times More Load than C-Channel

### Application - Specific Materials

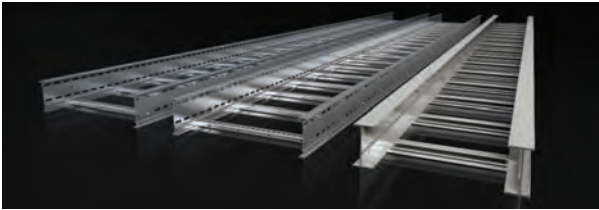

- Hot-dip galvanized steel
- 316 Stainless Steel
- Marine-grade, copper-free aluminum
- Ensures the best material for the application to carry the load over the longest span

Application Specific Materials Maximize Options

### Splice Plate Design



- Enhances the structural integrity and strength of the system, reducing support requirements
- UL Classified as an equipment grounding conductor, eliminating bonding jumpers

Splice Plates Enhance Structural Integrity

### Application - Specific Specialty Splices



- Patented design
- Designed for thermal expansion and contraction
- Structural integration maintains load carrying capacity, reducing support requirements

Specialty Splice Plates Allow Load Transfer

### Fitting Designs



- Industry-leading 75mm to 100mm tangents
- Maximizes strength and load carrying capacity, reducing support requirements

75mm or 100mm Tangents

# Structural Steel Savings

## Support Recommendations Horizontal Bends

### NEMA Standard 900mm (36") Radii

- Attached ladder supported within 600mm of splice
- Fittings supported at radius center point on both sides
- Three total supports recommended per fitting

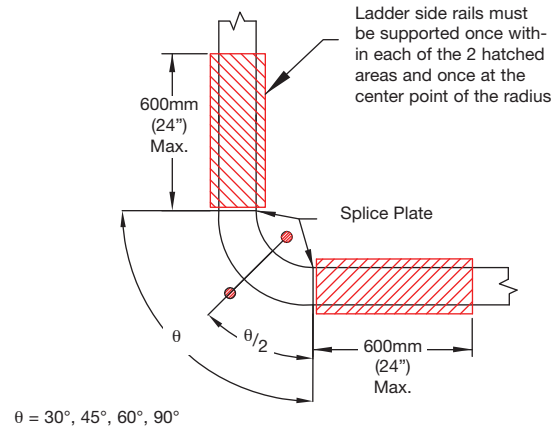

## B-Line Recommendations

### Option 1 900mm (36") Max Radii

- Attached ladder supported up to half span (3000mm max)
- Fittings supported within 30° of radius center point on both sides
- One support recommended per fitting with flexibility for placement and distance on ladder supports

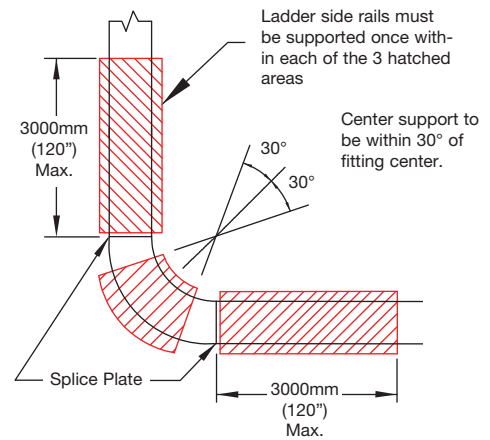

### Option 1 900mm (36") Max Radii

- Attached ladder supported within 600mm of splice
- Fitting support is eliminated
- Two total supports recommended per fitting

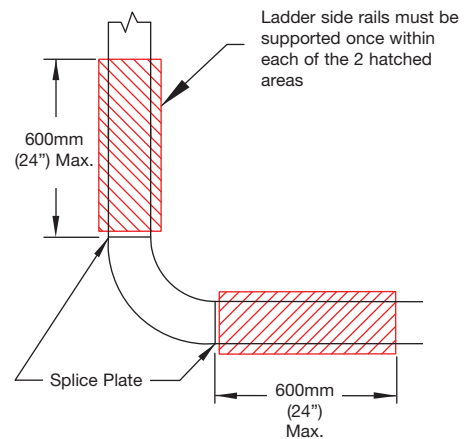

## Support Recommendations Horizontal Tees

### NEMA Standard 900mm (36") Radii

- Attached ladder supported within 600mm of splice
- Fittings supported once on each side rail
- Six total supports recommended per fitting

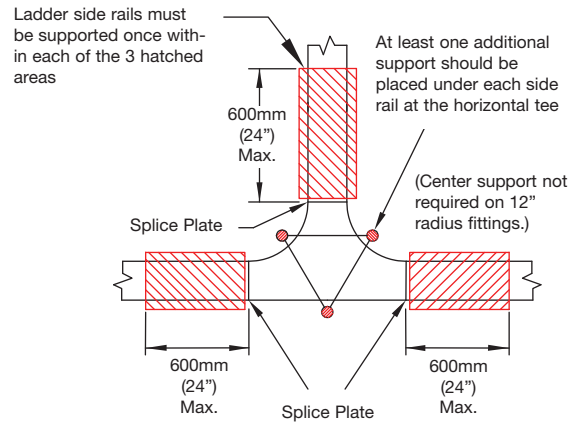

## B-Line Recommendations

### Option 1 900mm (36") Max Radii

- Attached ladder supported up to half span (3000mm max)
- Fittings supported twice within defined area
- Two supports recommended per fitting with flexibility for placement and distance on ladder supports

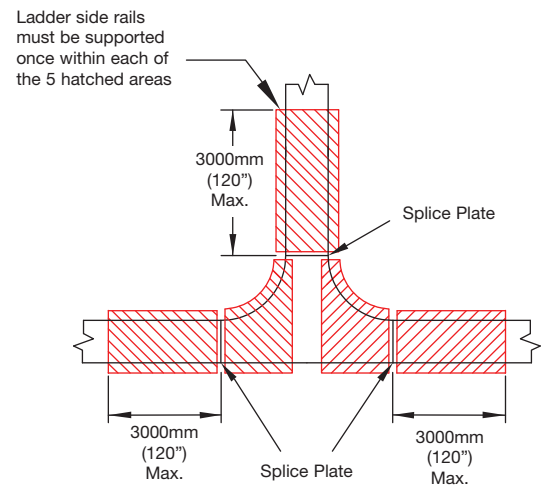

### Option 2 900mm (36") Max Radii

- Attached ladder supported within 600mm of splice
- Fitting supports are eliminated
- Three total supports recommended per fitting

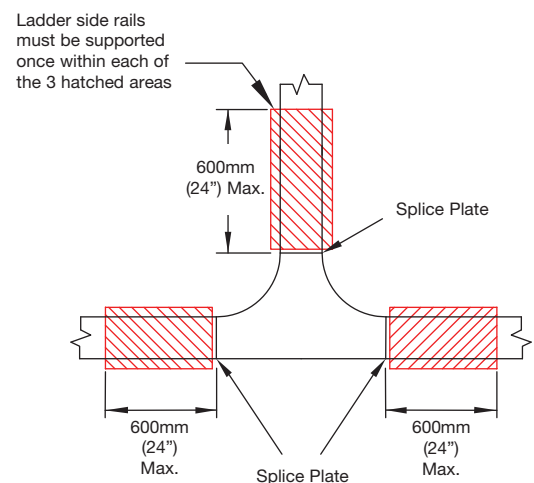

# Structural Steel Savings

## Support Recommendations Horizontal Crosses

### NEMA Standard 900mm (36") Radii

- Attached ladder supported within 600mm of splice
- Fittings supported once on each side rail
- Eight total supports recommended per fitting

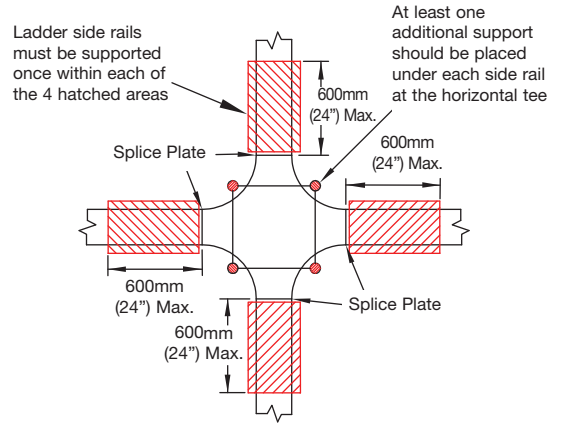

## B-Line Recommendations

### Options 1 & 2 900mm (36") Max Radii

- Attached ladder supported up to half span (3000mm max)
- Fitting supported twice within defined area
- Two supports recommended per fitting with flexibility for placement and distance on ladder supports

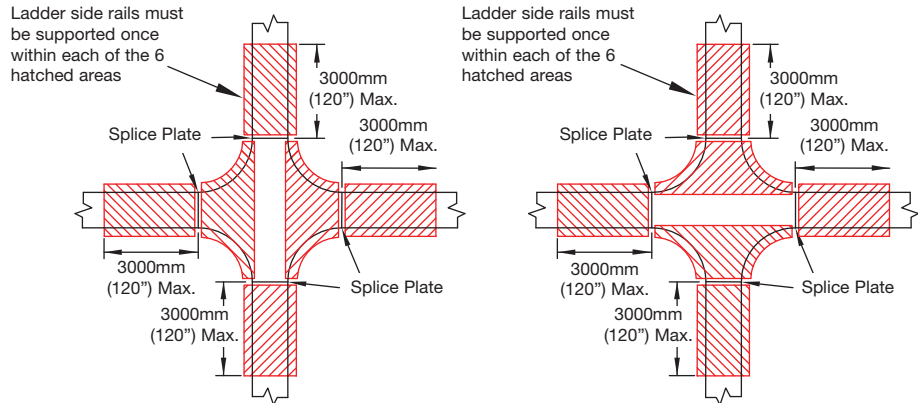

### Option 3 900mm (36") Max Radii

- Attached ladder supported within 600mm of splice
- Fitting supports are eliminated
- Four total supports recommended per fitting

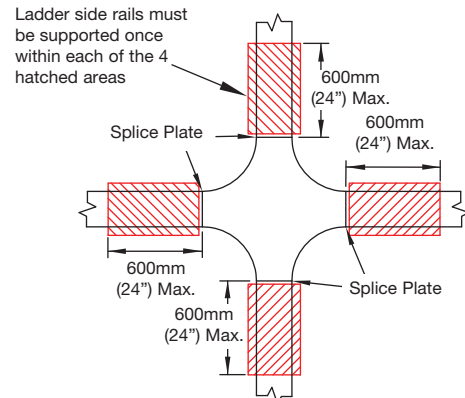

## Support Recommendations Vertical Inside/Outside Bends

### NEMA Standard 900mm (36") Radii

- Attached ladder supported within 600mm of splice
- Fittings supported Twice on each side rail
- Three total supports recommended per fitting

Vertical cabletray elbows at the top of runs should be supported at each end. At the bottom of runs, they should be supported at the top of the elbow and within the hatch area.

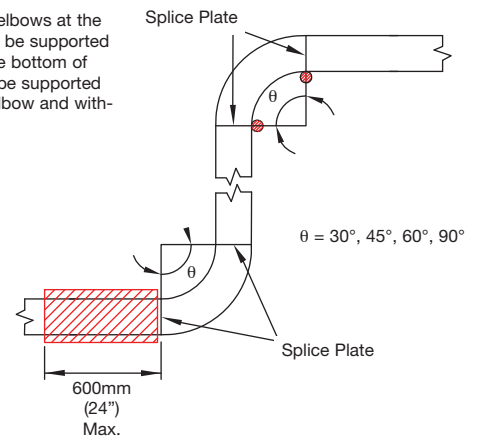

## B-Line Recommendations

### Options 1 & 2 900mm (36") Max Radii

- Attached ladder supported up to half span (3000mm max)
- Fitting supported once on each side rail
- One total support recommended per fitting with flexibility for placement and distance on ladder supports

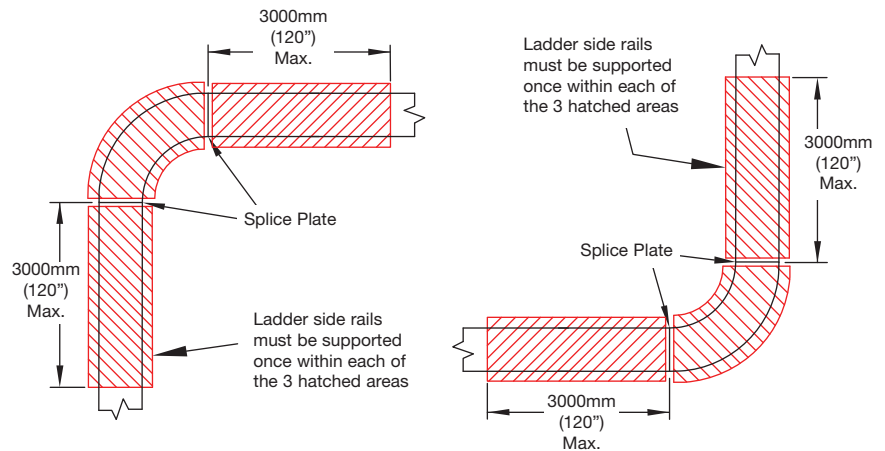

### Option 3 900mm (36") Max Radii

- Attached ladder supported within 300mm of splice and a maximum of 3000mm straight section in the transition between the fittings
- Fitting supports once on each side rail
- One total support recommended per fitting with flexibility for placement and distance on ladder supports

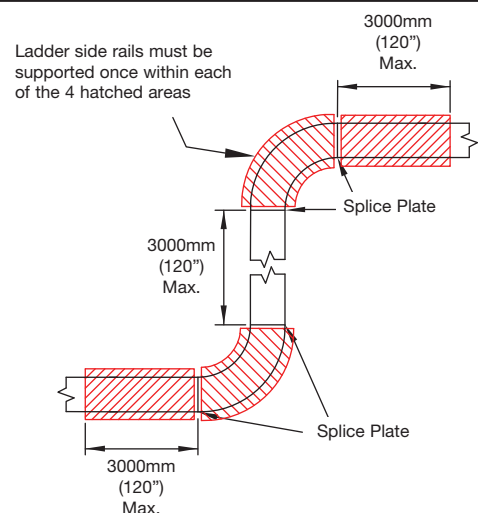

# Cable Ladder Selection Guide

B-Line hot dip galvanized and stainless steel cable ladder, manufactured and tested to IEC standards, are considered the premier product offering for any industrial cable management application. Three cable ladder series are available to help optimize design and lower total installed cost.

**High Performance Ladder (HPL) Series** – Designed to reduce overall weight in weight sensitive environments while increasing strength. Ideal for offshore and modular applications where weight reduction is imperative. Visit [www.cooperbline.com/hpl](http://www.cooperbline.com/hpl) to learn more.

- Lightweight – design optimized to exceed load requirements while keeping weight to a minimum
- Stainless steel 316 construction
- I-Beam side rail - maximizes strength
- Rolled components add strength
- Slotted side rails help reduce labor by eliminating the need to drill new splice holes after cutting
- Slotted rungs for cable and accessory attachment
- ABS Type Approved
- DNV Certified load tests

**Standard Duty Ladder (SDL) Series** – Designed for applications where long spans (3m to 6m) can be utilized to decrease support costs while maintaining load requirements. Ideal for any cable management application where high cable loads are required.

- Long Spans – Available in 3 meter and 6 meter lengths.
- Designed for use with 6m spans and still maintain high cable loads, while reducing support requirements.
- Structural Steel Savings support recommendations apply (see pages 5-10)
- Available in Stainless steel 316 and Hot-Dip Galvanized
- I-Beam side rail - maximizes strength over longer spans
- Rolled components add strength
- Slotted side rails help reduce labor by eliminating the need to drill new splice holes after cutting
- Slotted rungs for cable and accessory attachment
- ABS Type Approved

**Heavy Duty Ladder (HDL) Series** – Designed for extreme cable and environmental load conditions where long spans (3m to 6m) can be utilized to decrease support costs. Ideal for heavy industrial applications where environmental conditions such as wind, snow, and ice add significant load requirements.

- Superior Strength – Maximized material efficiency for maximized loads
- Structural Steel Savings support recommendations apply (see page 5-10)
- Available in Stainless steel 316 and Hot-Dip Galvanized
- I-Beam side rail - maximizes strength over longer spans
- Rolled components add strength
- Slotted side rails reduce labor by eliminating the need to drill new splice holes after cutting
- Slotted rungs for cable and accessory attachment
- ABS Type Approved

## Perforated & Solid Bottom Cable Tray Selection Guide

The B-Line perforated and solid bottom cable tray portion of this catalog is divided into two sections:

- Northern Asia (pages 53-78)
- Southern Asia (pages 79-104)

The differentiation between the geographic regions is based solely upon product manufacturing locations – Korea for Northern Asia, and Malaysia for Southern Asia and Australia

All perforated and solid bottom cable tray part numbers designate either a ‘NA’ or a ‘SA’ at the end to denote the manufacturing location. The following is an example of the same part with different manufacturing location designations.

Part Numbering Example	
Part Number	Manufacturing Location
P025VCP15SS-400-3000-NA	Korea
P025VCP15SS-400-3000-SA	Malaysia

Perforated and Solid Bottom Cable Tray product selection should be dependent upon the region that is closest to the final destination of the product.

For example, for product with a destination of Sydney Australia, it is recommended to use Southern Asia part numbers to ensure the lowest possible freight cost. Providing part numbers dependent upon manufacturing location allows our customers to reduce total cost by reducing freight to their project destination from the manufacturing facility.

For reference and as a general guideline, use the following to help determine which section of the catalog should be used.

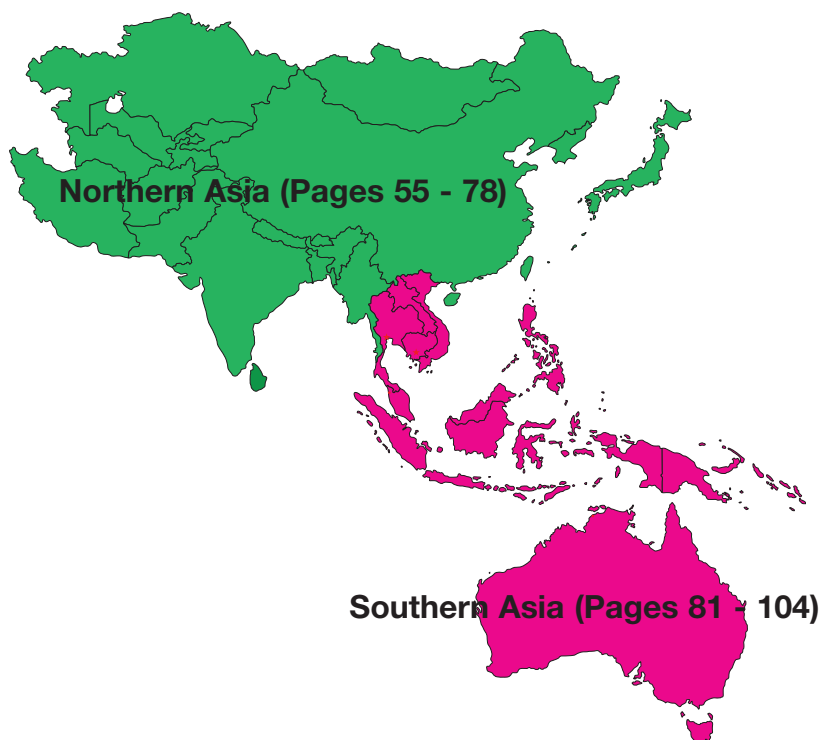

# Cable Ladder Construction

## Cable Ladder Construction - Side Rails

B-Line cable ladder side rails have an engineered I-Beam shape to provide system integrity. The I-Beam is the most efficient structural shape, providing strength without increasing the weight of the side rail itself. This shape, in conjunction with the slots in the side rails, offers the optimum design.

In addition, the I-Beam shape has a number of other advantages:

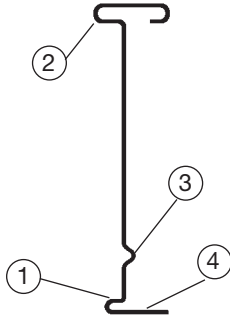

- 1) Roll-formed steel increases the strength of the steel itself
- 2) Enlarged top flange adds stiffness to the system
- 3) Bend in side rail to lock in rung position and provide more material for a solid weld
- 4) Bottom rail surface provides positive support for rungs
- 5) Slotted side rail design reduces installation time

## Profile Dimensions

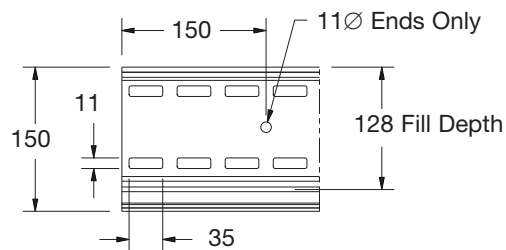
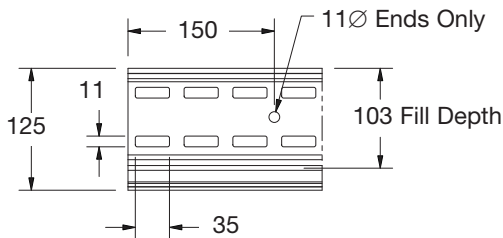
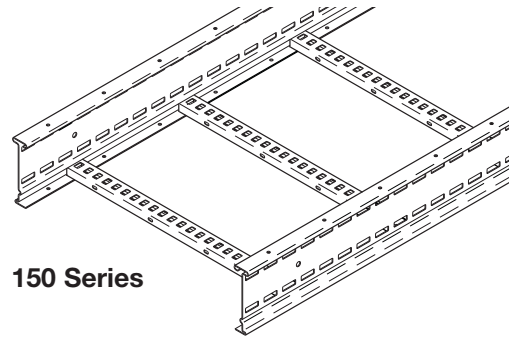
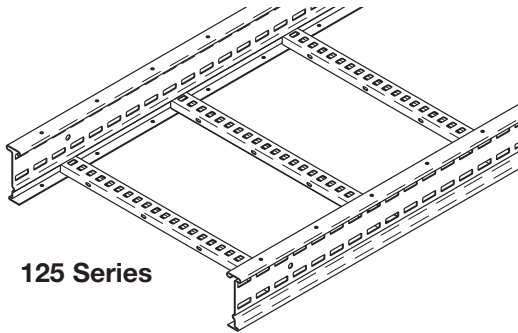

Dimensions are in mm

## Side Rails: Strength and Safe Working Load

Side rails provide the strength of the ladder system. The load ratings for the side rails in this catalog are based on testing to IEC 61537, 2006 Edition, Test Type II. Values in the catalog load charts are based upon allowable deflection and safe working loads calculated using a 1.7 factor of safety.

## Cable Ladder Construction - Rungs

Rungs are designed to maintain the system strength and provide a convenient place to affix cables. All rungs have slots on the upper surface, sized for M10 hardware, to allow for the attachment of banding or cleats.

### Rungs

Standard rungs (C) have a profile as shown in the rung profiles below. Spacing is 300mm, measured center-to-center. The standard rung orientation is all rung openings down (D) with options of all rung openings up (U), or alternating rung openings up and down (A). There are two profiles of rungs available as shown in the rung profiles dimensions below. A standard rung version (C) and a strut rung version (B).

### Rung Options

- **Rung Spacing:** Rungs can be spaced at intervals other than 300mm on straight sections only. To order an alternate rung spacing, change the default “300” value for the spacing following the material type or finish. Non-standard rung spacing is not available on fittings.

***Example:** 125G200CA15ILL-0600-3000 is a ladder with 125mm height, hot dip galvanized finish, 200mm rung spacing, SDL Series, 600mm width, and a 3m length.*

- **Strut Rung:** A strut-type profile can be ordered instead of the standard profile. To order a strut-type rung, change the default “C” value for standard rung to a “B” for strut-type rung.

***Example:** 125G300BA15ILL-0600-3000 is a ladder with 125mm height, hot dip galvanized finish, 300mm rung spacing, strut type rung, SDL Series, 600mm width, and a 3m length.*

- **Rung Orientation:** Rungs can be oriented with open side up or alternating, instead of the standard down orientation. To order rungs with all up or alternating orientation, change the default “D” value for down rungs to “U” for all rungs with open side up or “A” for alternating up and down rungs.

***Example:** 125G300CU15ILL-0600-3000 is a ladder with 125mm height, hot dip galvanized finish, 300mm rung spacing, standard rung, all rungs oriented with open side up, SDL Series, 600mm width, and a 3m length.*

### Rung Profile Dimensions

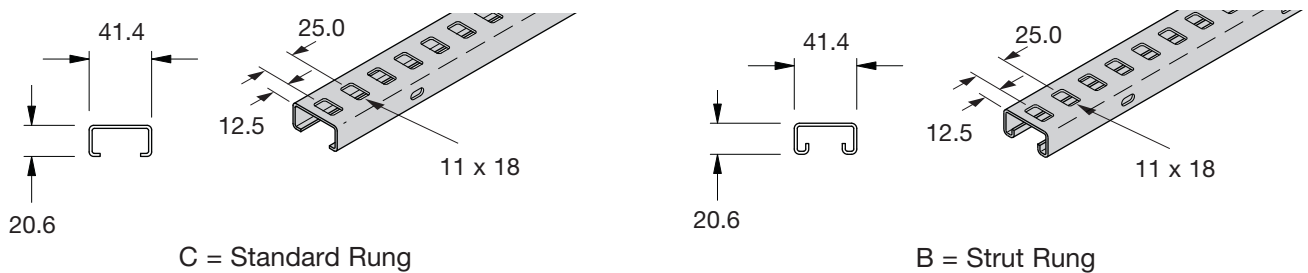

Dimensions are in mm

# Cable Ladder Construction

## Cable Ladder Construction - Fittings

B-Line cable ladder fittings are designed to carry loads greater than the straight sections. The C-shape of the fitting side rails is designed with the same height and width for easy attachment to straight sections.

### Fittings

All fittings have a straight tangent section at each end. The tangent allows the splice plate to be flush against both the straight section and the fitting when they are connected, increasing the contact surface area and the strength of the overall system.

Standard rung spacing for fittings is 300mm, measured center-to-center, and the standard rung orientation is down. Different rung types and orientations are available (see “Cable Ladder Construction - Rungs” reference page 14).

### Fitting Options

- **Radius:** Alternate radiuses may be available on request. Please consult B-Line for applications where a radius other than 300mm, 600mm, 900mm, or 1200mm is required.

### Profile Dimensions

**125mm  
Side Rail  
Height**

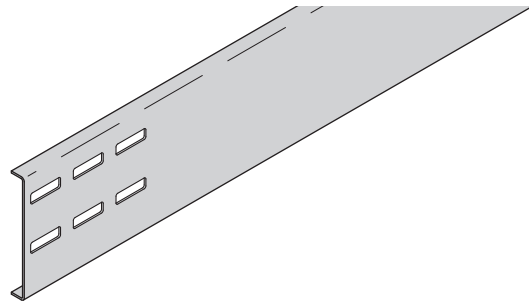
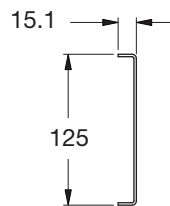

*Dimensions are in mm*

**150mm  
Side Rail  
Height**

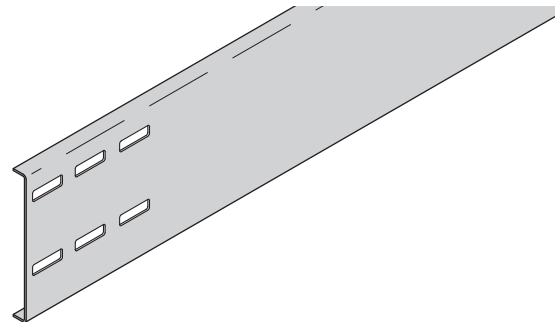
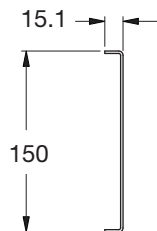

# Cable Ladder - Straight Sections & Covers

Ladders & Covers



# Cable Ladder - Straight Sections

## High Performance Ladder (HPL) Series

### Straight Section Part Numbering

Example: 125 X 300 C D 12I LL - 0600 - 3000

Height (mm)	Material	* Rung Spacing (mm)	* Rung Shape	* Rung Orientation	Side Rail	Ladder Straight Section	Width (mm)	Length (mm)
125	X =	200	C	D =	12I =		0150	3000
150	Stainless Steel 316	300	Profile	Down	HPL Series		0300	6000
							0450	
							0600	
							0750	
							0900	

\* Other Options Available - See "Cable Ladder Construction"

Splice plates not supplied with straight sections. One (1) pair required to connect to system. See pages 37 & 38.

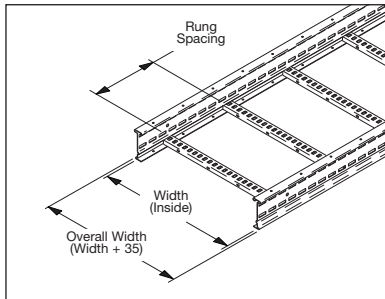

Certification #  
HOU-470-13-216



Approval #  
13-HS1047406-PDA

Height	Side Rail Dimensions	Series	Material	Span (m)	Loads † (kg/m)
125mm		HPL	SS6	3	345
				4	166
				5	99
				6	90

Height	Side Rail Dimensions	Series	Material	Span (m)	Loads † (kg/m)
150mm		HPL	SS6	3	391
				4	212
				5	130
				6	98

Height	Material		Tray Width					
			150mm	300mm	450mm	600mm	750mm	900mm
125mm	SS6	kg/m	4.4	4.8	5.3	5.7	6.6	7.1
		Strength to Weight Ratio*	78.4	71.9	65.1	60.5	52.3	48.6
150mm	SS6	kg/m	4.8	5.3	5.7	6.2	7.0	7.5
		Strength to Weight Ratio*	81.5	73.8	68.6	63.1	55.9	52.1

\* Strength to Weight Ratio determined by dividing 3m span load by weight.

† All tests conducted per IEC 61537 Test Type II with LHD-123X, 900mm width, and 300mm rung spacing.

All dimensions are in millimeters unless otherwise specified.

# Cable Ladder - Straight Sections

## Standard Duty Ladder (SDL) & Heavy Duty Ladder (HDL) Series

Ladders & Covers

### Straight Section Part Numbering

Example: **125 G 300 C D 15I LL - 0600 - 3000**

Height (mm)	Material	* Rung Spacing (mm)	* Rung Shape	* Rung Orientation	Side Rail	Ladder Straight Section	Width (mm)	Length (mm)
125	Galvanized Steel	200	C Profile	D Down	15I =	0600	0150	3000
150		300			20I =		0300	6000
	Stainless Steel 316				HDL Series		0450	
							0600	
							0750	
							0900	

\* Other Options Available - See "Cable Ladder Construction"

Splice plates not supplied with straight sections. One (1) pair required to connect to system. See pages 37 & 38.

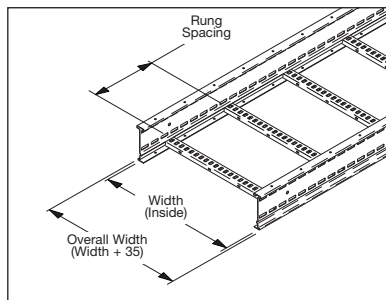

Approval # 13-HS1047406-PDA

Height	Side Rail Dimensions	Series	Material	Span (m)	Loads (kg/m)	Material	Span (m)	Loads (kg/m)			
125mm		SDL	HDG	3	420	SS6	3	441			
				4	310		4	323			
				5	200		5	206			
				6	90		6	88			
				3	442		3	458			
				4	341		4	340			
		5		241	5		223				
		6		140	6		105				
					HDL						

Height	Side Rail Dimensions	Series	Material	Span (m)	Loads (kg/m)	Material	Span (m)	Loads (kg/m)			
150mm		SDL	HDG	3	525	SS6	3	474			
				4	394		4	356			
				5	263		5	239			
				6	132		6	121			
				3	577		3	482			
				4	446		4	368			
		5		315	5		254				
		6		184	6		140				
					HDL						

All tests conducted per IEC 61537 Test Type II with 900mm width, and 300mm rung spacing.

All dimensions are in millimeters unless otherwise specified.

# Cable Ladder - Straight Section Covers

## Covers

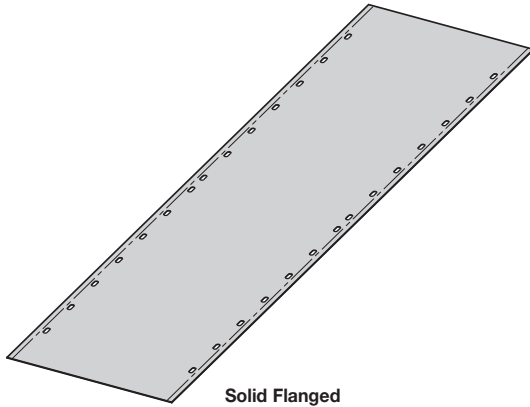

Solid Flanged

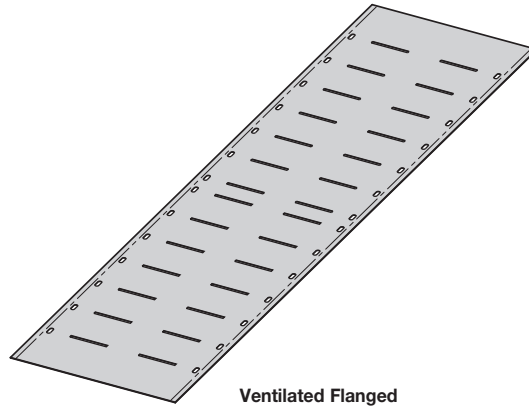

Ventilated Flanged

**A full range of covers is available for straight sections and fittings.**

**Solid covers** should be used when maximum enclosure of the cable is desired and no accumulation of heat is expected.

**Ventilated covers** allow heat to escape.

B-Line recommends that covers be placed on vertical cable ladder runs to a height of 1.5m to 2.5m above the floor to isolate both cables and personnel.

Cover clamps are not included with the cover and must be ordered separately.

### Steel Cover Part Numbering

Prefix  
Example: **CIF S G15 LL - 0600 - 3000**

Flanged Cover	Cover Type	Material	Ladder Straight Section	Width (mm)	Length *
	<b>S</b> = Solid	<b>G15</b> = Galvanized Steel		<b>0150</b> = 150mm	<b>1500</b> = 1.5m
	<b>L</b> = Ventilated	<b>X10</b> = Stainless Steel 316		<b>0300</b> = 300mm	<b>3000</b> = 3.0m
	<b>P</b> = Peaked			<b>0450</b> = 450mm	
				<b>0600</b> = 600mm	
				<b>0750</b> = 750mm	
				<b>0900</b> = 900mm	

\* 750 (750mm) and 900 (900mm) widths only available in 1500 (1.5m) lengths.

# Cable Ladder - Cover Clamps

Ladders & Covers

## High Performance Cover Clamp

- Withstands 76m/s (170 MPH) wind loads
- Sold per piece with hardware
- (\*) Finish: Insert MZ or X for SS6

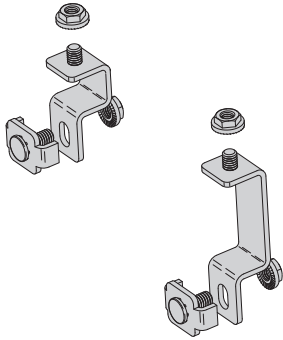

### Number of Clamps for Wind Speeds Up To 76m/s (170 MPH)

Assembly	Cover Size	# of Clamps
Straight Section	1.5m length	4
	3.0m length	6
30° - 60° Horizontal Bend	All radii	4
90° Horizontal Bend	150mm to 600mm radius	4
	900mm to 1200mm radius	6
30° - 60° Vertical Bend	All radii	4
90° Vertical Bend	150mm to 600mm radius	4
	900mm to 1200mm radius	6
Horizontal Tee	150mm to 600mm radius	6
	900mm to 1200mm radius	8
Horizontal Cross	150mm to 600mm radius	8
	900mm to 1200mm radius	12

Catalog Number	Description	Raised Height	
		mm	In.
LCCSD(*)	Standard Clamp	--	--
LCCSDR(*)	Raised Clamp	35.5	1.4

Visit [www.cooperblinc.com/ccs](http://www.cooperblinc.com/ccs) for installation instructions and additional clamp quantities for other fittings.

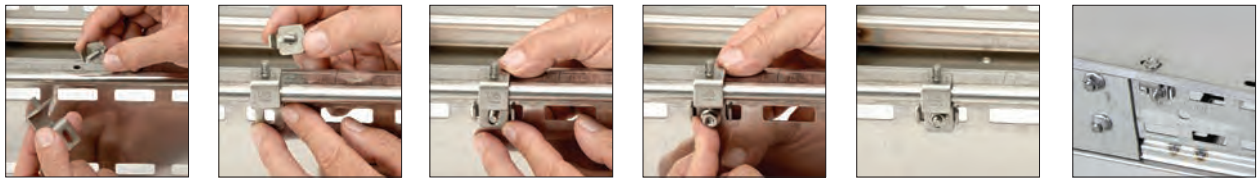

## Standard Cover Clamp

- For indoor service only
- Sold per piece with hardware
- (\*) Finish: Insert G or SS6

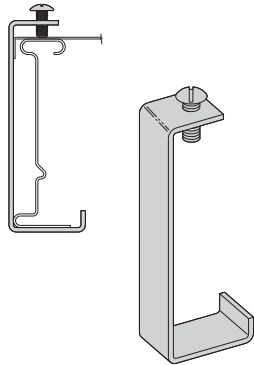

Ladder Height	Catalog No.
125	LCL125(*)
150	LCL150(*)

### Quantity of Standard Cover Clamps Required

Assembly	Cover Size	# of Clamps
Straight Section	1.5m length	4
	3.0m length	6
Horizontal & Vertical Bend	All radii	4
Horizontal Tees	All radii	6
Horizontal Crosses	All radii	8

Note: When using the Heavy Duty Cover Clamp, only one-half the number of clamps stated above is required.

## Heavy Duty Cover Clamp

- Recommended for outdoor service
- (xx) Insert tray width - 150 to 900
- Includes M10 hardware
- (\*) Finishes available: G or SS6

Ladder Height mm	Catalog No.
125	LCH125(*) (xx)
150	LCH150(*) (xx)

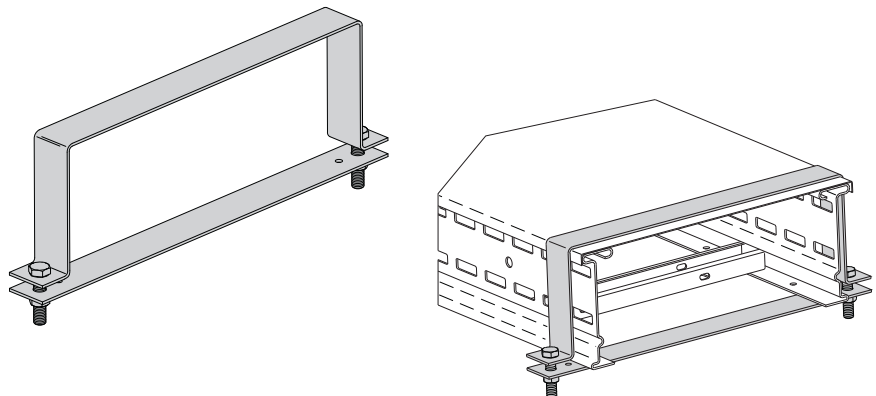

All dimensions are in millimeters unless otherwise specified.

# Cable Ladder - Fittings & Covers

Fittings & Covers



# Cable Ladder Fittings

B-Line Cable Ladder Fittings are designed to support cables as they transition directions. Side rails are C-shaped with standard 300mm rung spacing.

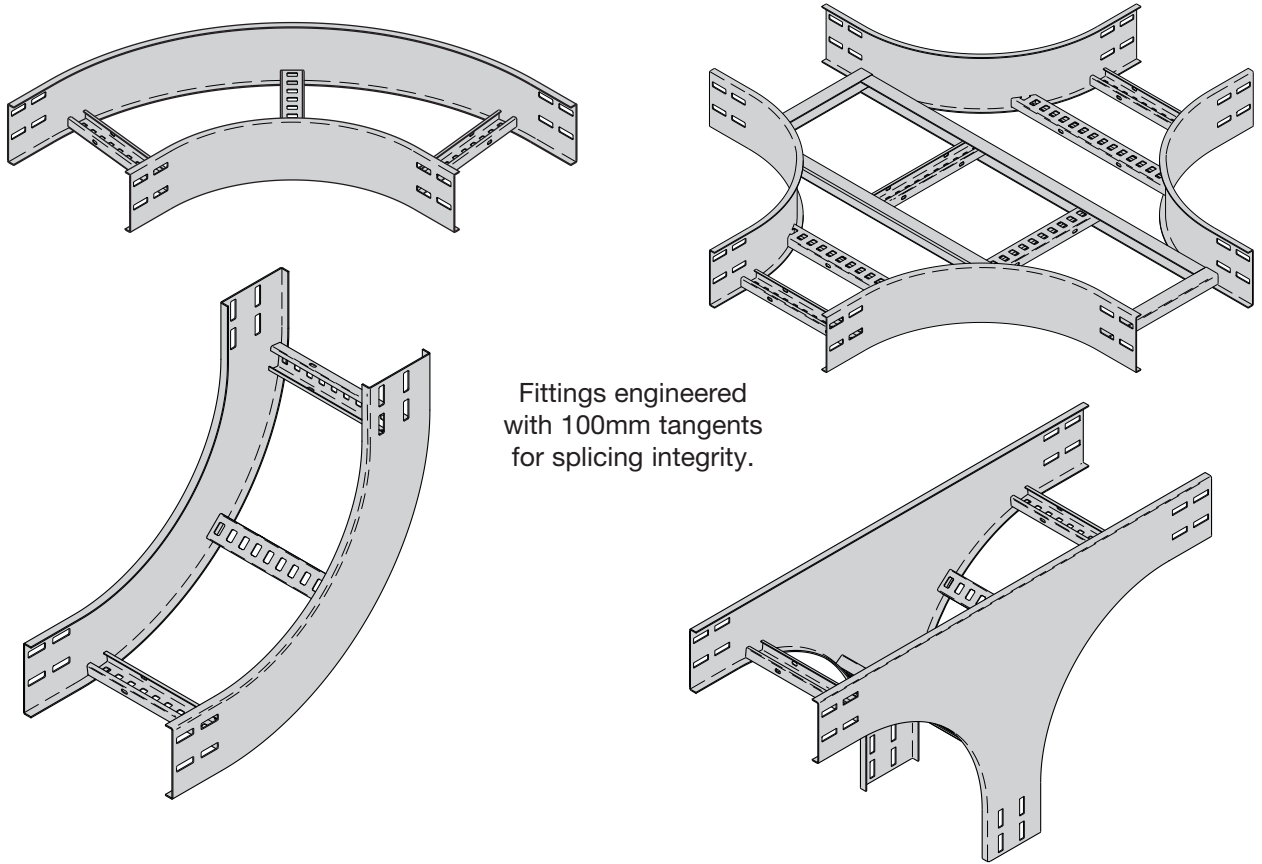

Fittings engineered with 100mm tangents for splicing integrity.

Fittings & Covers

## Fittings Part Numbering

Prefix  
Example: **125 G 300 C D 20C** LVO - 0600 - 90 R0600

Height (mm)	Material	Rung Spacing (mm)	* Rung Shape	* Rung Orientation	Side Rail	Ladder Fitting Type	Width (mm)	Angle † (°)	Radius (mm)
125 = 125mm	** G = Galvanized Steel	300 = 300mm	C = Standard Profile	D = Down	12C = HPL Series	LHB = Horizontal Bend LVI = Vertical Inside Bend LVO = Vertical Outside Bend	0150 = 150mm 0300 = 300mm	30 45 60	R0300 = 300mm
150 = 150mm	X = Stainless Steel 316	* Other Options Available See "Cable Ladder Construction"			15C = SDL Series 20C = HDL Series	LHT = Horizontal Tee † LHX = Horizontal Cross † LVTD = Vertical Tee Down † LVTU = Vertical Tee Up † LCSF = Cable Support Fitting †	0450 = 450mm 0600 = 600mm 0750 = 750mm 0900 = 900mm	90	R0600 = 600mm R0900 = 900mm R1200 = 1200mm

\*\* Not Available with HPL Series

† No angle designation required on these fittings. See fitting page when creating part numbers.

All dimensions are in millimeters unless otherwise specified.

# Cable Ladder Fittings

## Horizontal Bends 90° (LHB)

Splice plates not supplied with fittings.  
Order standard splice plates separately from page 37.  
One (1) pair required to connect to system.

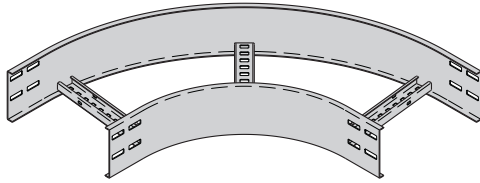

90° Horizontal Bend

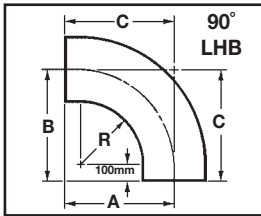

Fittings & Covers

Bend Radius R mm	Ladder Width mm	90° Horizontal Bend Dimensions			
		Catalog No.	A mm	B mm	C mm
300	150	(Pre)LHB-0150-90R0300	475	475	475
	300	(Pre)LHB-0300-90R0300	550	550	550
	450	(Pre)LHB-0450-90R0300	625	625	625
	600	(Pre)LHB-0600-90R0300	700	700	700
	750	(Pre)LHB-0750-90R0300	775	775	775
	900	(Pre)LHB-0900-90R0300	850	850	850
600	150	(Pre)LHB-0150-90R0600	775	775	775
	300	(Pre)LHB-0300-90R0600	850	850	850
	450	(Pre)LHB-0450-90R0600	925	925	925
	600	(Pre)LHB-0600-90R0600	1000	1000	1000
	750	(Pre)LHB-0750-90R0600	1075	1075	1075
	900	(Pre)LHB-0900-90R0600	1150	1150	1150

**(Prefix)** See page 22 for catalog number prefix.

Width dimensions are to inside wall. Manufacturing tolerances apply to all dimensions.

Note: For 900mm and 1200mm bend radius dimensions, download submittals at [www.cooperline.com/iec](http://www.cooperline.com/iec)

## Horizontal Bends 60° (LHB)

Splice plates not supplied with fittings.  
Order standard splice plates separately from page 37.  
One (1) pair required to connect to system.

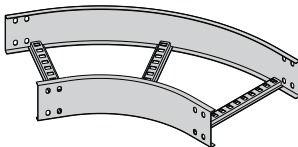

60° Horizontal Bend

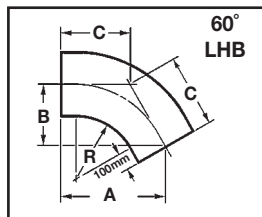

Bend Radius R mm	Ladder Width mm	60° Horizontal Bend Dimensions			
		Catalog No.	A mm	B mm	C mm
300	150	(Pre)LHB-0150-60R0300	476	275	317
	300	(Pre)LHB-0300-60R0300	541	312	360
	450	(Pre)LHB-0450-60R0300	606	350	404
	600	(Pre)LHB-0600-60R0300	670	387	447
	750	(Pre)LHB-0750-60R0300	735	425	490
	900	(Pre)LHB-0900-60R0300	800	425	534
600	150	(Pre)LHB-0150-60R0600	735	425	490
	300	(Pre)LHB-0300-60R0600	800	462	534
	450	(Pre)LHB-0450-60R0600	865	500	577
	600	(Pre)LHB-0600-60R0600	930	537	620
	750	(Pre)LHB-0750-60R0600	995	575	663
	900	(Pre)LHB-0900-60R0600	1060	612	707

**(Prefix)** See page 22 for catalog number prefix.

Width dimensions are to inside wall. Manufacturing tolerances apply to all dimensions.

Note: For 900mm and 1200mm bend radius dimensions, download submittals at [www.cooperline.com/iec](http://www.cooperline.com/iec)

## Horizontal Bends 45° (LHB)

Splice plates not supplied with fittings.  
Order standard splice plates separately from page 37.  
One (1) pair required to connect to system.

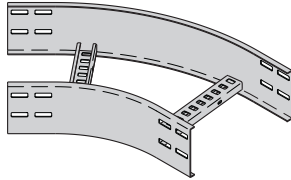

45° Horizontal Bend

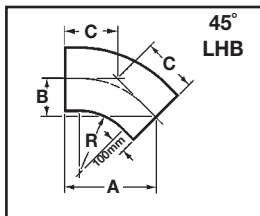

Bend Radius R mm	Ladder Width mm	45° Horizontal Bend Dimensions			
		Catalog No.	A mm	B mm	C mm
300	150	(Pre)LHB-0150-45R0300	437	181	256
	300	(Pre)LHB-0300-45R0300	490	203	287
	450	(Pre)LHB-0450-45R0300	543	225	318
	600	(Pre)LHB-0600-45R0300	596	247	349
	750	(Pre)LHB-0750-45R0300	649	269	380
	900	(Pre)LHB-0900-45R0300	702	291	411
600	150	(Pre)LHB-0150-45R0600	649	269	380
	300	(Pre)LHB-0300-45R0600	702	291	411
	450	(Pre)LHB-0450-45R0600	755	313	443
	600	(Pre)LHB-0600-45R0600	809	335	474
	750	(Pre)LHB-0750-45R0600	862	357	505
	900	(Pre)LHB-0900-45R0600	915	379	536

(Prefix) See page 22 for catalog number prefix.

Width dimensions are to inside wall. Manufacturing tolerances apply to all dimensions.

Note: For 900mm and 1200mm bend radius dimensions, download submittals at [www.cooperblinc.com/iec](http://www.cooperblinc.com/iec)

## Horizontal Bends 30° (LHB)

Splice plates not supplied with fittings.  
Order standard splice plates separately from page 37.  
One (1) pair required to connect to system.

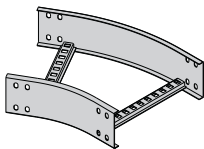

30° Horizontal Bend

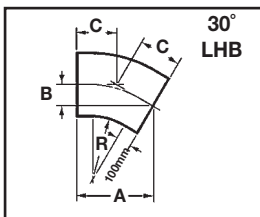

Bend Radius R mm	Ladder Width mm	30° Horizontal Bend Dimensions			
		Catalog No.	A mm	B mm	C mm
300	150	(Pre)LHB-0150-30R0300	375	100	200
	300	(Pre)LHB-0300-30R0300	412	110	221
	450	(Pre)LHB-0450-30R0300	450	120	241
	600	(Pre)LHB-0600-30R0300	487	130	261
	750	(Pre)LHB-0750-30R0300	525	140	281
	900	(Pre)LHB-0900-30R0300	562	150	301
600	150	(Pre)LHB-0150-30R0600	525	140	281
	300	(Pre)LHB-0300-30R0600	562	150	301
	450	(Pre)LHB-0450-30R0600	600	160	321
	600	(Pre)LHB-0600-30R0600	627	170	341
	750	(Pre)LHB-0750-30R0600	675	180	361
	900	(Pre)LHB-0900-30R0600	712	190	381

(Prefix) See page 22 for catalog number prefix.

Width dimensions are to inside wall. Manufacturing tolerances apply to all dimensions.

Note: For 900mm and 1200mm bend radius dimensions, download submittals at [www.cooperblinc.com/iec](http://www.cooperblinc.com/iec)

All dimensions are in millimeters unless otherwise specified.

# Cable Ladder Fittings

## Horizontal Tee (LHT)

Splice plates not supplied with fittings.  
Order standard splice plates separately from page 37.  
Two (2) pair required to connect to system.

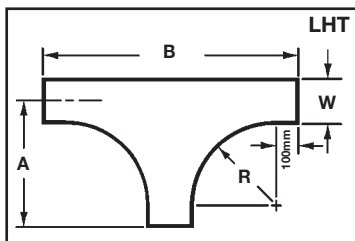
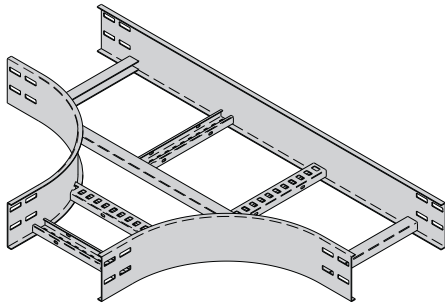

Bend Radius R mm	Ladder Width mm	Horizontal Cross		
		Catalog Number	Dimensions	
			A mm	B mm
300	150	(Pre)LHT-0150-R0300	475	950
	300	(Pre)LHT-0300-R0300	550	1000
	450	(Pre)LHT-0450-R0300	625	1250
	600	(Pre)LHT-0600-R0300	700	1400
	750	(Pre)LHT-0750-R0300	775	1500
	900	(Pre)LHT-0900-R0300	850	1700
600	150	(Pre)LHT-0150-R0600	775	1550
	300	(Pre)LHT-0300-R0600	850	1700
	450	(Pre)LHT-0450-R0600	925	1850
	600	(Pre)LHT-0600-R0600	1000	2000
	750	(Pre)LHT-0750-R0600	1075	2150
	900	(Pre)LHT-0900-R0600	1150	2300

(Prefix) See page 22 for catalog number prefix.

Width dimensions are to inside wall. Manufacturing tolerances apply to all dimensions.

Note: For 900mm and 1200mm bend radius dimensions, download submittals at [www.cooperbline.com/iec](http://www.cooperbline.com/iec)

## Horizontal Cross (LHX)

Splice plates not supplied with fittings.  
Order standard splice plates separately from page 37.  
Three (3) pair required to connect to system.

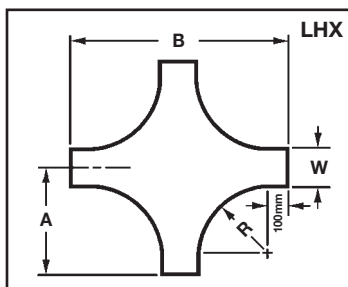
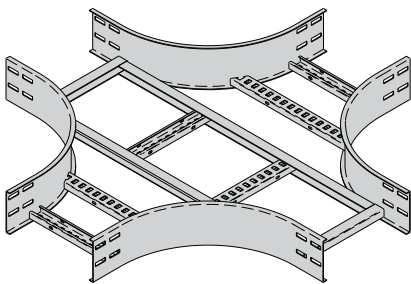

Bend Radius R mm	Ladder Width mm	Horizontal Cross		
		Catalog Number	Dimensions	
			A mm	B mm
300	150	(Pre)LHX-0150-R0300	475	900
	300	(Pre)LHX-0300-R0300	550	1100
	450	(Pre)LHX-0450-R0300	625	1250
	600	(Pre)LHX-0600-R0300	700	1400
	750	(Pre)LHX-0750-R0300	775	1550
	900	(Pre)LHX-0900-R0300	850	1700
600	150	(Pre)LHX-0150-R0600	775	1550
	300	(Pre)LHX-0300-R0600	850	1700
	450	(Pre)LHX-0450-R0600	925	1850
	600	(Pre)LHX-0600-R0600	1000	2000
	750	(Pre)LHX-0750-R0600	1075	2150
	900	(Pre)LHX-0900-R0600	1150	2300

(Prefix) See page 22 for catalog number prefix.

Width dimensions are to inside wall. Manufacturing tolerances apply to all dimensions.

Note: For 900mm and 1200mm bend radius dimensions, download submittals at [www.cooperbline.com/iec](http://www.cooperbline.com/iec)

# Cable Ladder Fittings

## Vertical Bends 90° & 60° (LVO, LVI)

Splice plates not supplied with fittings.  
Order standard splice plates separately from page 37.  
One (1) pair required to connect to system.

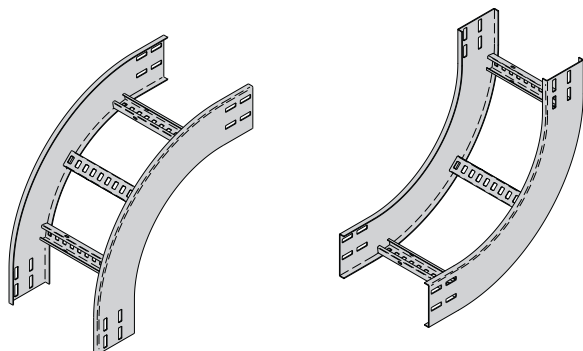

90° Vertical Outside

90° Vertical Inside

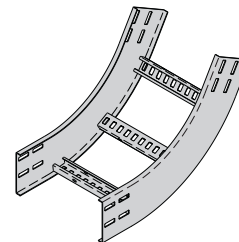
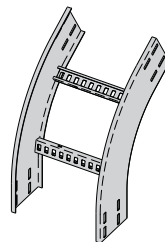

60° Vertical Outside

60° Vertical Inside

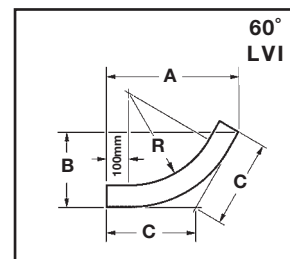
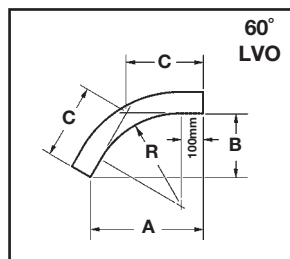
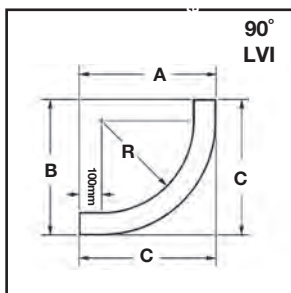
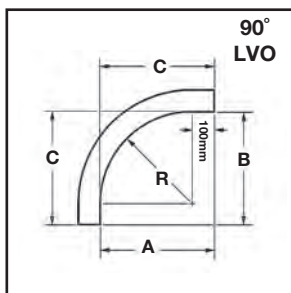

Bend Radius R mm	Ladder Width Insert mm	(*) Insert "VO" for Vert. Outside Bend "VI" for Vert. Inside Bend Catalog No.	VO Side Rail Height 125mm - 150mm			VI Side Rail Height					
			A mm	B mm	C mm	125mm			150mm		
						A mm	B mm	C mm	A mm	B mm	C mm
<b>90°</b>											
300	150	(Prefix)L(*)-0150-90R0300	400	400	400	525	525	525	550	550	550
	300	(Prefix)L(*)-0300-90R0300									
	450	(Prefix)L(*)-0450-90R0300									
	600	(Prefix)L(*)-0600-90R0300									
	750	(Prefix)L(*)-0750-90R0300									
	900	(Prefix)L(*)-0900-90R0300									
600	150	(Prefix)L(*)-0150-90R0600	700	700	700	825	825	825	850	850	850
	300	(Prefix)L(*)-0300-90R0600									
	450	(Prefix)L(*)-0450-90R0600									
	600	(Prefix)L(*)-0600-90R0600									
	750	(Prefix)L(*)-0750-90R0600									
	900	(Prefix)L(*)-0900-90R0600									
<b>60°</b>											
300	150	(Prefix)L(*)-0150-60R0300	410	237	273	518	300	345	540	312	360
	300	(Prefix)L(*)-0390-60R0300									
	450	(Prefix)L(*)-0450-60R0300									
	600	(Prefix)L(*)-0600-60R0300									
	750	(Prefix)L(*)-0750-60R0300									
	900	(Prefix)L(*)-0900-60R0300									
600	150	(Prefix)L(*)-0150-60R0600	670	386	446	778	449	519	780	462	533
	300	(Prefix)L(*)-0300-60R0600									
	450	(Prefix)L(*)-0450-60R0600									
	600	(Prefix)L(*)-0600-60R0600									
	750	(Prefix)L(*)-0750-60R0600									
	900	(Prefix)L(*)-0900-60R0600									

(Prefix) See page 22 for catalog number prefix.  
Manufacturing tolerances apply to all dimensions.

Note: For 900mm and 1200mm bend radius dimensions, download submittals at [www.cooperline.com/iec](http://www.cooperline.com/iec)

All dimensions are in millimeters unless otherwise specified.

# Cable Ladder Fittings

## Vertical Bends 45° & 30° (LVO, LVI)

Splice plates not supplied with fittings.  
Order standard splice plates separately from page 37.  
One (1) pair required to connect to system.

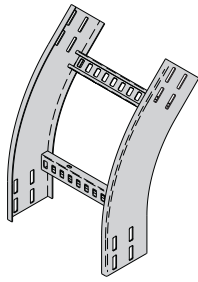

45° Vertical Outside

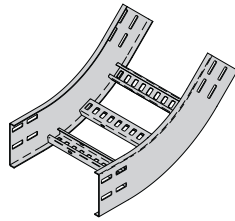

45° Vertical Inside

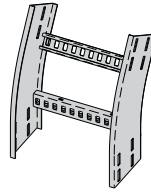

30° Vertical Outside

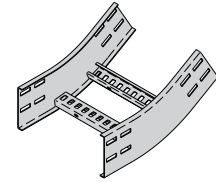

30° Vertical Inside

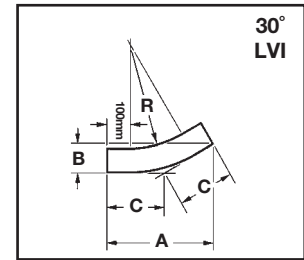
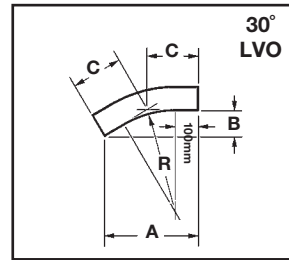
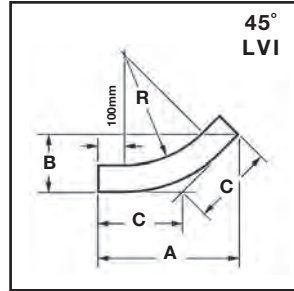
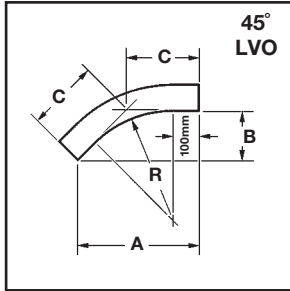

Bend Radius R mm	Ladder Width Insert mm	(*) Insert "VO" for Vert. Outside Bend "VI" for Vert. Inside Bend Catalog No.	VO Side Rail Height 125mm - 150mm			VI Side Rail Height					
			A mm	B mm	C mm	125mm			150mm		
						A mm	B mm	C mm	A mm	B mm	C mm
<b>45°</b>											
300	150	(Prefix)L(*)-0150-45R0300	383	159	226	469	195	276	681	283	400
	300	(Prefix)L(*)-0300-45R0300									
	450	(Prefix)L(*)-0450-46R0300									
	600	(Prefix)L(*)-0600-45R0300									
	750	(Prefix)L(*)-0750-45R0300									
600	900	(Prefix)L(*)-0900-45R0300	595	246	373	487	203	286	699	290	411
	150	(Prefix)L(*)-0150-45R0600									
	300	(Prefix)L(*)-0300-45R0600									
	450	(Prefix)L(*)-0450-45R0600									
	600	(Prefix)L(*)-0600-45R0600									
300	750	(Prefix)L(*)-0750-45R0600	337	90	180	399	107	214	417	110	221
	900	(Prefix)L(*)-0900-45R0600									
	150	(Prefix)L(*)-0150-30R0300									
	300	(Prefix)L(*)-0390-30R0300									
	450	(Prefix)L(*)-0450-30R0300									
600	600	(Prefix)L(*)-0600-30R0300	487	130	261	549	147	294	562	150	301
	750	(Prefix)L(*)-0750-30R0300									
	900	(Prefix)L(*)-0900-30R0300									
	150	(Prefix)L(*)-0150-30R0600									
	300	(Prefix)L(*)-0300-30R0600									
300	450	(Prefix)L(*)-0450-30R0600	337	90	180	399	107	214	417	110	221
	600	(Prefix)L(*)-0600-30R0600									
	750	(Prefix)L(*)-0750-30R0600									
	900	(Prefix)L(*)-0900-30R0600									
	150	(Prefix)L(*)-0150-30R0300									
600	300	(Prefix)L(*)-0390-30R0300	487	130	261	549	147	294	562	150	301
	450	(Prefix)L(*)-0450-30R0600									
	600	(Prefix)L(*)-0600-30R0600									
	750	(Prefix)L(*)-0750-30R0600									
	900	(Prefix)L(*)-0900-30R0600									

(Prefix) See page 22 for catalog number prefix.  
Manufacturing tolerances apply to all dimensions.

Note: For 900mm and 1200mm bend radius dimensions, download submittals at  
[www.cooperblineline.com/iec](http://www.cooperblineline.com/iec)

All dimensions are in millimeters unless otherwise specified.

## Vertical Tee Up/Down (LVTU/LVTD)

Splice plates not supplied with fittings.

Order standard splice plates separately from page 37.

Two (2) pair required to connect to system.

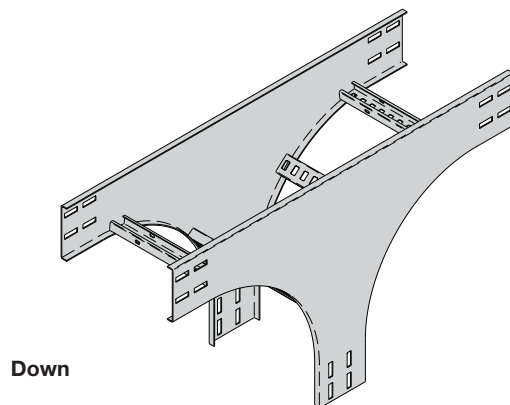
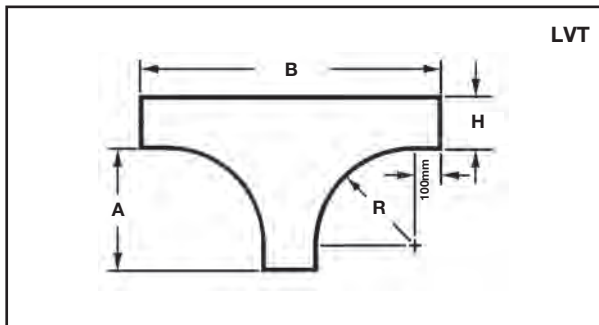

Down

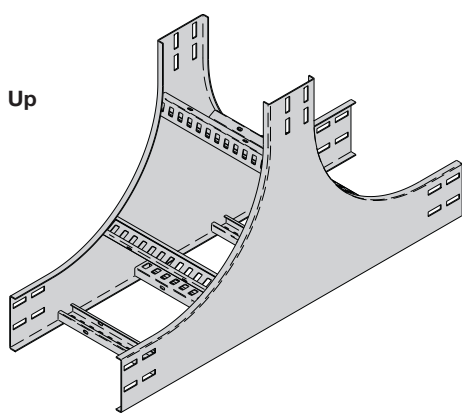

Up

Fittings & Covers

Bend Radius R mm	Ladder Width mm	Vertical Tee Down Catalog No.	Vertical Tee Up Catalog No.	Side Rail Height "H"			
				125mm		150mm	
				A mm	B mm	A mm	B mm
300	150	(Prefix)LVTD-0150-R0300	(Prefix)LVTU-0150-R0300	400	925	400	950
	300	(Prefix)LVTD-0300-R0300	(Prefix)LVTU-0300-R0300				
	450	(Prefix)LVTD-0450-R0300	(Prefix)LVTU-0450-R0300				
	600	(Prefix)LVTD-0600-R0300	(Prefix)LVTU-0600-R0300				
	750	(Prefix)LVTD-0750-R0300	(Prefix)LVTU-0750-R0300				
	900	(Prefix)LVTD-0900-R0300	(Prefix)LVTU-0900-R0300				
600	150	(Prefix)LVTD-0150-R0600	(Prefix)LVTU-0150-R0600	700	1525	700	1550
	300	(Prefix)LVTD-0300-R0600	(Prefix)LVTU-0300-R0600				
	450	(Prefix)LVTD-0450-R0600	(Prefix)LVTU-0450-R0600				
	600	(Prefix)LVTD-0600-R0600	(Prefix)LVTU-0600-R0600				
	750	(Prefix)LVTD-0750-R0600	(Prefix)LVTU-0750-R0600				
	900	(Prefix)LVTD-0900-R0600	(Prefix)LVTU-0900-R0600				

(Prefix) See page 22 for catalog number prefix.

Manufacturing tolerances apply to all dimensions.

Note: For 900mm and 1200mm bend radius dimensions, download submittals at [www.cooperbline.com/iec](http://www.cooperbline.com/iec)

All dimensions are in millimeters unless otherwise specified.

# Cable Ladder Fittings

## Cable Support Fittings (LCSF)

Splice plates not supplied with fittings.  
 Order standard splice plates separately from page 37.  
 One (1) pair required to connect to system.

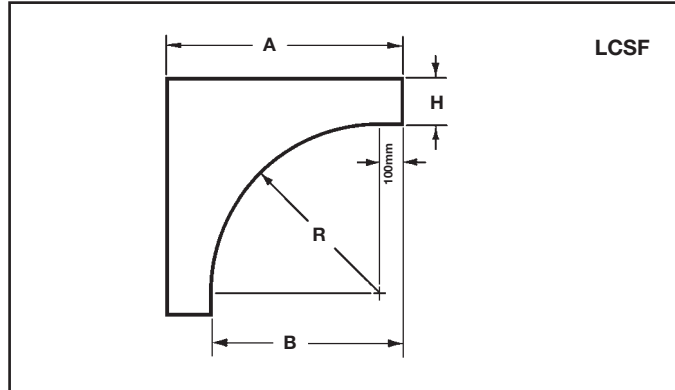
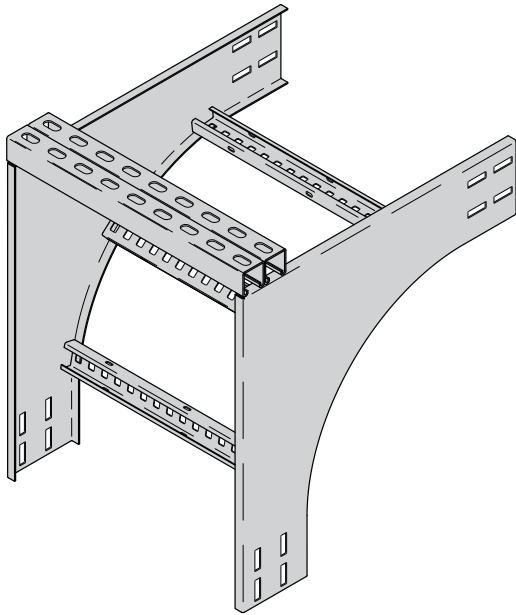

This fitting is recommended for use at the top of vertical runs to support the weight of the cables. The top cross brace is drilled for installing eye bolts, ordered separately.

Bend Radius R mm	Ladder Width mm	Catalog No. mm	Side Rail Height "H"			
			125mm		150mm	
			A mm	B mm	A mm	B mm
300	150	(Prefix)LCSF-0150-R0300	525	400	550	400
	300	(Prefix)LCSF-0300-R0300				
	450	(Prefix)LCSF-0450-R0300				
	600	(Prefix)LCSF-0600-R0300				
	750	(Prefix)LCSF-0750-R0300				
	900	(Prefix)LCSF-0900-R0300				
600	150	(Prefix)LCSF-0150-R0600	825	700	850	700
	300	(Prefix)LCSF-0300-R0600				
	450	(Prefix)LCSF-0450-R0600				
	600	(Prefix)LCSF-0600-R0600				
	750	(Prefix)LCSF-0750-R0600				
	900	(Prefix)LCSF-0900-R0600				

**(Prefix)** See page 22 for catalog number prefix.

Manufacturing tolerances apply to all dimensions.

Note: For 900mm and 1200mm bend radius dimensions, download submittals at [www.cooperblineline.com/iec](http://www.cooperblineline.com/iec)

# Cable Ladder Fittings

B-Line Cable Ladder Reducing and Expanding Fittings are designed to support cables as they transition directions. Side rails are C-shaped with standard 300mm rung spacing.

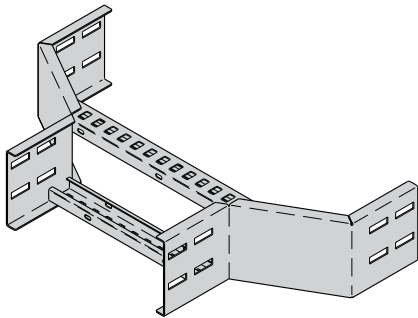
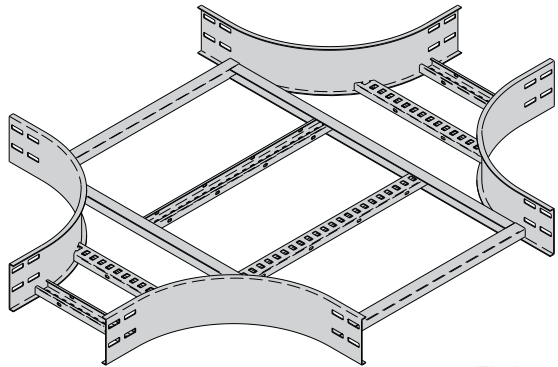

Fittings engineered with 100mm tangents for splicing integrity.

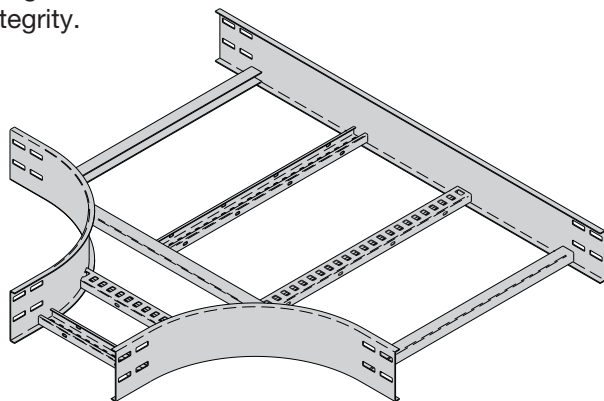
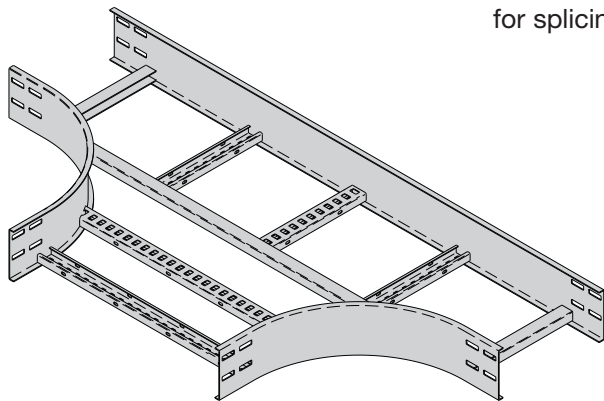

Fittings & Covers

## Reducing & Expanding Fittings Part Numbering

Prefix

Example: **125 G 300 C D 15C LRR - 0600 - 0300 R0300**

Height	Material	Rung Spacing (mm)	* Rung Shape	* Rung Orientation	Side Rail	Ladder Fitting Type	Width 1	Width 2	Radius
<b>125</b> = 125mm	<b>** G</b> = Galvanized Steel	<b>300</b> = 300mm	<b>C</b> = Standard Profile	<b>D</b> = Down	<b>12C</b> = HPL Series	<b>LRR</b> = Right Reducer <b>LLR</b> = Left Reducer <b>LSR</b> = Straight Reducer	<b>0150</b> = 150mm <b>0300</b> = 300mm <b>0450</b> = 450mm <b>0600</b> = 600mm <b>0750</b> = 750mm <b>0900</b> = 900mm	<b>0150</b> = 150mm <b>0300</b> = 300mm <b>0450</b> = 450mm <b>0600</b> = 600mm <b>0750</b> = 750mm <b>0900</b> = 900mm	<b>R0300</b> = 300mm <b>R0600</b> = 600mm <b>R0900</b> = 900mm <b>R1200</b> = 1200mm
<b>150</b> = 150mm	<b>X</b> = Stainless Steel 316	<b>* Other Options Available</b> See "Cable Ladder Construction"			<b>15C</b> = SDL Series <b>20C</b> = HDL Series	<b>LET</b> = Horizontal Expanding Tee <b>LRT</b> = Horizontal Reducing Tee <b>LRX</b> = Horizontal Expanding/Reducing Cross			

\*\* Not available with HPL Series

All dimensions are in millimeters unless otherwise specified.

# Cable Ladder Fittings

## Reducers (LLR, LSR, LRR)

Splice plates not supplied with fittings.  
Order standard splice plates separately from page 37.  
One (1) pair required to connect to system.

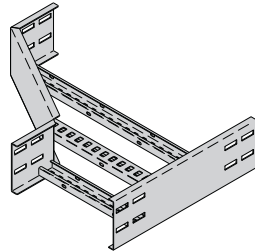

Left Reducer

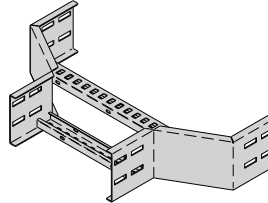

Straight Reducer

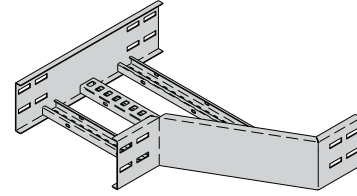

Right Reducer

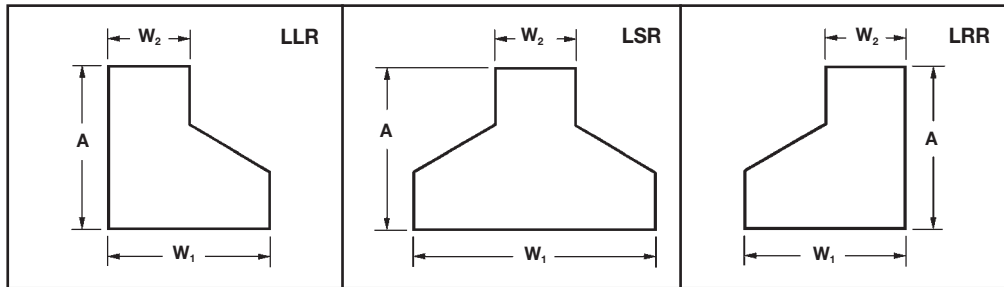

Ladder Width		Left Hand Reducer		Straight Reducer		Right Hand Reducer	
W <sub>1</sub>	W <sub>2</sub>	Catalog No.	A	Catalog No.	A	Catalog No.	A
mm	mm		mm		mm		mm
300	150	(Prefix)LLR-0300-0150	337	(Prefix)LSR-0300-0150	293	(Prefix)LRR-0300-0150	337
450	150	(Prefix)LLR-0450-0150	423	(Prefix)LSR-0450-0150	337	(Prefix)LRR-0450-0150	423
	300	(Prefix)LLR-0450-0300	337	(Prefix)LSR-0450-0300	293	(Prefix)LRR-0450-0300	337
600	150	(Prefix)LLR-0600-0150	510	(Prefix)LSR-0600-0150	380	(Prefix)LRR-0600-0150	510
	300	(Prefix)LLR-0600-0300	423	(Prefix)LSR-0600-0300	337	(Prefix)LRR-0600-0300	423
	450	(Prefix)LLR-0600-0450	337	(Prefix)LSR-0600-0450	293	(Prefix)LRR-0600-0450	337
750	150	(Prefix)LLR-0750-0150	596	(Prefix)LSR-0750-0150	423	(Prefix)LRR-0750-0150	596
	300	(Prefix)LLR-0750-0300	510	(Prefix)LSR-0750-0300	380	(Prefix)LRR-0750-0300	510
	450	(Prefix)LLR-0750-0450	423	(Prefix)LSR-0750-0450	337	(Prefix)LRR-0750-0450	423
	600	(Prefix)LLR-0750-0600	337	(Prefix)LSR-0750-0600	293	(Prefix)LRR-0750-600	337
900	150	(Prefix)LLR-0900-0150	683	(Prefix)LSR-0900-0150	467	(Prefix)LRR-0900-0150	683
	300	(Prefix)LLR-0900-0300	596	(Prefix)LSR-0900-0300	423	(Prefix)LRR-0900-0300	596
	450	(Prefix)LLR-0900-0450	510	(Prefix)LSR-0900-0450	380	(Prefix)LRR-0900-0450	510
	600	(Prefix)LLR-0900-0600	423	(Prefix)LSR-0900-0600	337	(Prefix)LRR-0900-0600	423
	750	(Prefix)LLR-0900-0750	337	(Prefix)LSR-0900-0750	293	(Prefix)LRR-0900-0750	337

(Prefix) See page 30 for catalog number prefix.

Width dimensions are to inside wall.

Manufacturing tolerances apply to all dimensions.

Note: For 900mm and 1200mm bend radius dimensions, download submittals at [www.cooperblineline.com/iec](http://www.cooperblineline.com/iec)

## Horizontal Expanding Tee (LET)

Splice plates not supplied with fittings.  
Order standard splice plates separately from page 37.  
Two (2) pair required to connect to system.

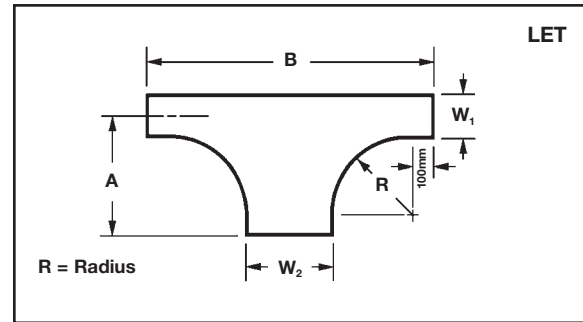
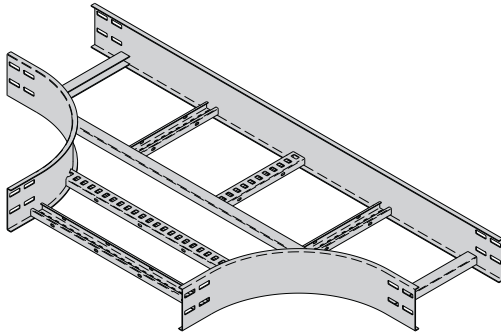

Bend Radius	Ladder Width		Horizontal Expanding Tee			
	R mm	W <sub>1</sub> mm	W <sub>2</sub> mm	Dimensions		
			Catalog Number	A mm	B mm	
300	150	300	(Pre)LET-0150-0300-R0300	475	1100	
		450	(Pre)LET-0150-0450-R0300	475	1250	
		600	(Pre)LET-0150-0600-R0300	475	1400	
		750	(Pre)LET-0150-0750-R0300	475	1550	
		900	(Pre)LET-0150-0900-R0300	475	1700	
	300	300	450	(Pre)LET-0300-0450-R0300	550	1250
			600	(Pre)LET-0300-0600-R0300	550	1400
			750	(Pre)LET-0300-0750-R0300	550	1550
			900	(Pre)LET-0300-0900-R0300	550	1700
	450	450	600	(Pre)LET-0450-0600-R0300	625	1400
			750	(Pre)LET-0450-0750-R0300	625	1550
			900	(Pre)LET-0450-0900-R0300	625	1700
	600	600	750	(Pre)LET-0600-0750-R0300	700	1550
			900	(Pre)LET-0600-0900-R0300	700	1700
	600	150	300	(Pre)LET-0150-0300-R0600	775	1700
			450	(Pre)LET-0150-0450-R0600	775	1850
600			(Pre)LET-0150-0600-R0600	775	2000	
750			(Pre)LET-0150-0750-R0600	775	2150	
900			(Pre)LET-0150-0900-R0600	775	2300	
300		300	450	(Pre)LET-0300-0450-R0600	850	1850
			600	(Pre)LET-0300-0600-R0600	850	2000
			750	(Pre)LET-0300-0750-R0600	850	2150
			900	(Pre)LET-0300-0900-R0600	850	2300
450		450	600	(Pre)LET-0450-0600-R0600	925	2000
			750	(Pre)LET-0450-0750-R0600	925	2150
			900	(Pre)LET-0450-0900-R0600	925	2300
600		600	750	(Pre)LET-0600-0750-R0600	1000	2150
			900	(Pre)LET-0600-0900-R0600	1000	2300
750		900	(Pre)LET-0750-0900-R0600	1075	2300	

(Prefix) See page 30 for catalog number prefix.

Width dimensions are to inside wall.

Manufacturing tolerances apply to all dimensions.

Note: For 900mm and 1200mm bend radius dimensions, download submittals at [www.cooperblineline.com/iec](http://www.cooperblineline.com/iec)

All dimensions are in millimeters unless otherwise specified.

# Cable Ladder Fittings

## Horizontal Reducing Tee (LRT)

Splice plates not supplied with fittings.  
Order standard splice plates separately from page 37.  
Two (2) pair required to connect to system.

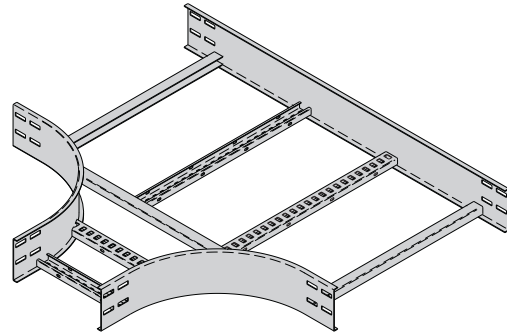
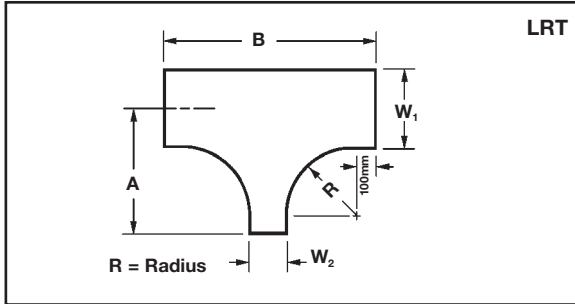

Bend Radius	Ladder Width		Horizontal Reducing Tee			
	R mm	W <sub>1</sub> mm	W <sub>2</sub> mm	Catalog Number	Dimensions	
				A mm	B mm	
300	300	150		(Pre)LRT-0300-0150-R0300	550	950
		150		(Pre)LRT-0450-0150-R0300	625	950
	450	300		(Pre)LRT-0450-0300-R0300	625	1100
		150		(Pre)LRT-0600-0150-R0300	700	950
	600	300		(Pre)LRT-0600-0300-R0300	700	1100
		450		(Pre)LRT-0600-0450-R0300	700	1250
	750	150		(Pre)LRT-0750-0150-R0300	775	950
		300		(Pre)LRT-0750-0300-R0300	775	1100
		450		(Pre)LRT-0750-0450-R0300	775	1250
		600		(Pre)LRT-0750-0600-R0300	775	1400
	900	150		(Pre)LRT-0900-0150-R0300	850	950
		300		(Pre)LRT-0900-0300-R0300	850	1100
450			(Pre)LRT-0900-0450-R0300	850	1250	
600			(Pre)LRT-0900-0600-R0300	850	1400	
600	300	150		(Pre)LRT-0300-0150-R0600	830	1550
		150		(Pre)LRT-0450-0150-R0600	925	1550
	450	300		(Pre)LRT-0450-0300-R0600	925	1700
		150		(Pre)LRT-0600-0150-R0600	1000	1550
	600	300		(Pre)LRT-0600-0300-R0600	1000	1700
		450		(Pre)LRT-0600-0450-R0600	1000	1850
	750	150		(Pre)LRT-0750-0150-R0600	1075	1550
		300		(Pre)LRT-0750-0300-R0600	1075	1700
		450		(Pre)LRT-0750-0450-R0600	1075	1850
		600		(Pre)LRT-0750-0600-R0600	1075	2000
	900	150		(Pre)LRT-0900-0150-R0600	1150	1550
		300		(Pre)LRT-0900-0300-R0600	1150	1700
450			(Pre)LRT-0900-0450-R0600	1150	1850	
600			(Pre)LRT-0900-0600-R0600	1150	2000	
	750		(Pre)LRT-0900-0750-R0600	1150	2150	

**(Prefix)** See page 30 for catalog number prefix.

Width dimensions are to inside wall.

Manufacturing tolerances apply to all dimensions.

Note: For 900mm and 1200mm bend radius dimensions, download submittals at [www.cooperbline.com/iec](http://www.cooperbline.com/iec)

## Horizontal Expanding/Reducing Cross (LRX)

Splice plates not supplied with fittings.  
 Order standard splice plates separately from page 37.  
 Three (3) pair required to connect to system.

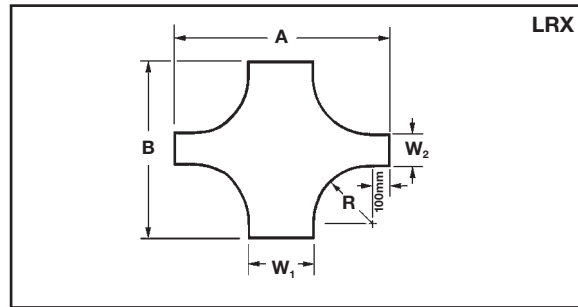
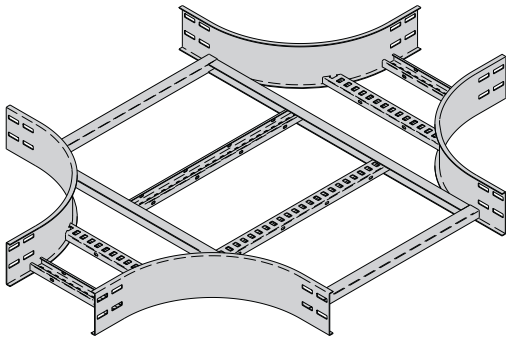

Fittings & Covers

Bend Radius R mm	Ladder Width		Horizontal Expanding/Reducing Cross			
	W <sub>1</sub> mm	W <sub>2</sub> mm	Catalog Number	A mm	B mm	
300	300	150	(Pre)LRX-0300-0150-R0300	1100	950	
		450	150	(Pre)LRX-0450-0150-R0300	1250	950
			300	(Pre)LRX-0450-0300-R0300	1250	1100
	600	150	(Pre)LRX-0600-0150-R0300	1400	950	
		300	(Pre)LRX-0600-0300-R0300	1400	1100	
		450	(Pre)LRX-0600-0450-R0300	1400	1250	
			(Pre)LRX-0600-0600-R0300	1400	1250	
	750	150	(Pre)LRX-0750-0150-R0300	1550	950	
		300	(Pre)LRX-0750-0300-R0300	1550	1100	
		450	(Pre)LRX-0750-0450-R0300	1550	1250	
		600	(Pre)LRX-0750-0600-R0300	1550	1400	
			(Pre)LRX-0750-0750-R0300	1550	1400	
900	150	(Pre)LRX-0900-0150-R0300	1700	950		
	300	(Pre)LRX-0900-0300-R0300	1700	1100		
	450	(Pre)LRX-0900-0450-R0300	1700	1250		
	600	(Pre)LRX-0900-0600-R0300	1700	1400		
	750	(Pre)LRX-0900-0750-R0300	1700	1550		
600	300	150	(Pre)LRX-0300-0150-R0600	1700	1550	
		450	150	(Pre)LRX-0450-0150-R0600	1850	1550
			300	(Pre)LRX-0450-0300-R0600	1850	1700
	600	150	(Pre)LRX-0600-0150-R0600	2100	1550	
		300	(Pre)LRX-0600-0300-R0600	2100	1700	
		450	(Pre)LRX-0600-0450-R0600	2100	1850	
	750	150	(Pre)LRX-0750-0150-R0600	2150	1550	
		300	(Pre)LRX-0750-0300-R0600	2150	1700	
		450	(Pre)LRX-0750-0450-R0600	2150	1850	
		600	(Pre)LRX-0750-0600-R0600	2150	2000	
	900	150	(Pre)LRX-0900-0150-R0600	2300	1550	
		300	(Pre)LRX-0900-0300-R0600	2300	1700	
		450	(Pre)LRX-0900-0450-R0600	2300	1850	
		600	(Pre)LRX-0900-0600-R0600	2300	2000	
		750	(Pre)LRX-0900-0750-R0600	2300	2150	

(Prefix) See page 30 for catalog number prefix.

Width dimensions are to inside wall.

Manufacturing tolerances apply to all dimensions.

Note: For 900mm and 1200mm bend radius dimensions, download submittals at [www.cooperline.com/iec](http://www.cooperline.com/iec)

All dimensions are in millimeters unless otherwise specified.

# Cable Ladder Fittings

## Fitting Covers

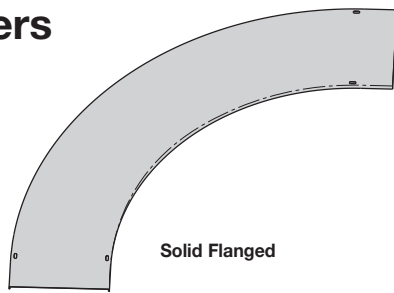

Solid Flanged

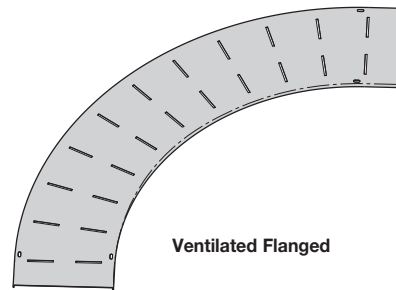

Ventilated Flanged

A full range of covers are available for fittings.

**Solid covers** should be used when maximum enclosure of the cable is desired and no accumulation of heat is expected.

**Ventilated covers** allow heat to escape.

B-Line recommends that covers be placed on vertical cable ladder runs to a height of 1.5m to 2.5m above the floor to isolate both cables and personnel.

**Flanged covers** have a 12mm flange. Cover clamps are not included with the cover and must be ordered separately.

### Fitting Covers Part Numbering

Example: **CCF S G15 LVO - 0600 - 90 R0600 - 150\*\*\***

Flanged Cover	Cover Type	Material	Ladder Fitting Type	Width	Angle † (°)	Radius	Side Rail Height
	<b>S</b> = Solid	<b>G15</b> = Galvanized Steel	<b>LHB</b> = Horizontal Bend <b>LVI</b> = Vertical Inside Bend <b>LVO</b> = Vertical Outside Bend	<b>0150</b> = 150mm <b>0300</b> = 300mm <b>0450</b> = 450mm <b>0600</b> = 600mm <b>0750</b> = 750mm <b>0900</b> = 900mm	<b>30</b> <b>45</b> <b>60</b> <b>90</b>	<b>R0300</b> = 300mm <b>R0600</b> = 600mm <b>R0900</b> = 900mm <b>R1200</b> = 1200mm	<b>125</b> = 125mm <b>150</b> = 150mm
	<b>L</b> = Louvered	<b>X10</b> = Stainless Steel 316	<b>LHT</b> = Horizontal Tee † <b>LHX</b> = Horizontal Cross † <b>LVTD</b> = Vertical Tee Down † <b>LVTU</b> = Vertical Tee Up † <b>LCSF</b> = Cable Support Fitting †				*** Required for VO, VTD, CSF only
	<b>P</b> = Peaked						

† No angle designation required on these fitting covers.

### Expanding & Reducing Fitting Covers Part Numbering

Example: **CCF S X10 LRR - 0600 - 0300 R0300**

Flanged Cover	Cover Type	Material	Ladder Fitting Type	Width 1	Width 2	Radius
	<b>S</b> = Solid	<b>G15</b> = Galvanized Steel	<b>LRR</b> = Right Reducer <b>LLR</b> = Left Reducer <b>LSR</b> = Straight Reducer	<b>0150</b> = 150mm <b>0300</b> = 300mm <b>0450</b> = 450mm <b>0600</b> = 600mm <b>0750</b> = 750mm <b>0900</b> = 900mm	<b>0150</b> = 150mm <b>0300</b> = 300mm <b>0450</b> = 450mm <b>0600</b> = 600mm <b>0750</b> = 750mm <b>0900</b> = 900mm	<b>R0300</b> = 300mm <b>R0600</b> = 600mm <b>R0900</b> = 900mm <b>R1200</b> = 1200mm
	<b>L</b> = Louvered	<b>X10</b> = Stainless Steel 316	<b>LRX</b> = Expanding & Reducing Cross <b>LET</b> = Expanding Tee <b>LRT</b> = Reducing Tee			
	<b>P</b> = Peaked					

See page 20 for cover clamp options.

All dimensions are in millimeters unless otherwise specified.

# Cable Ladder Accessories

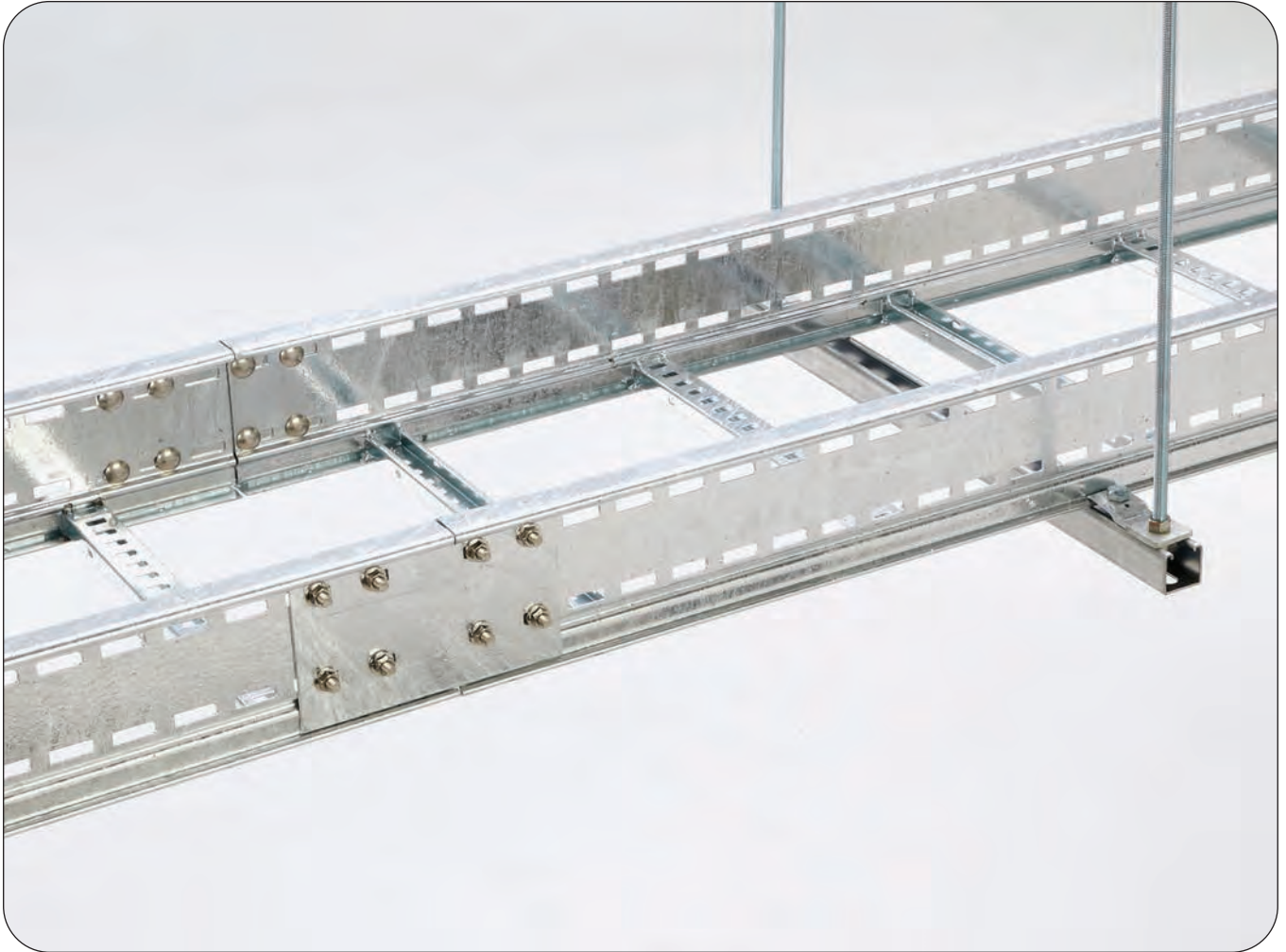

Accessories



# Cable Ladder Accessories

## Standard Splice Plates

- Not included with straight sections or fittings.
- Standard 8-slot pattern.
- Supplied in pairs with hardware.
- (\*) Insert G or SS6

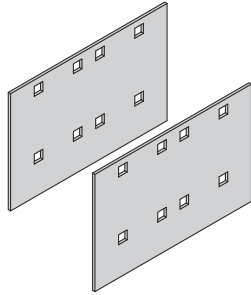

Ladder Height mm	Catalog No.
125	LSP125(*)
150	LSP150(*)

## Expansion Splice Plates

- Expansion plates allow for 25mm expansion or contraction of the cable ladder, or where expansion joints occur in the supporting structure.
- Supplied in pairs with hardware.
- (\*) Insert G or SS6

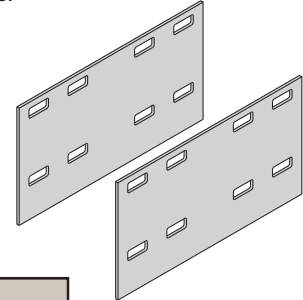

Ladder Height mm	Catalog No.
125	LES125(*)
150	LES150(*)

## Vertical Adjustable Splice Plates

- These plates provide for changes in elevation that do not conform to standard vertical fittings.
- Supplied in pairs with hardware.
- **Bonding Jumpers are not required.**
- (\*) Insert G or SS6

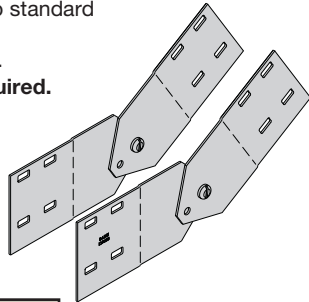

Ladder Height mm	Catalog No.
125	LVA125(*)
150	LVA150(*)

## Reducing Coupler Plate

- For offset transitions.
- Supplied as one plate with hardware.
- (\*) Insert G or SS6

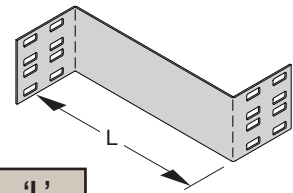

Ladder Height mm	Catalog No.	'L' mm
125	LSR125(*)150	150
	LSR125(*)300	300
	LSR125(*)450	450
	LSR125(*)600	600
	LSR125(*)750	750
150	LSR150(*)150	150
	LSR150(*)300	300
	LSR150(*)450	450
	LSR150(*)600	600
	LSR150(*)750	750

## Horizontal Adjustable Splice Plates

- Offered to adjust a cable ladder run for changes in direction in a horizontal plane that do not conform to standard horizontal fittings.
- Supplied in pairs with hardware.
- Rail extensions 1000mm length standard, LHA splices included.
- (\*) Insert G or SS6

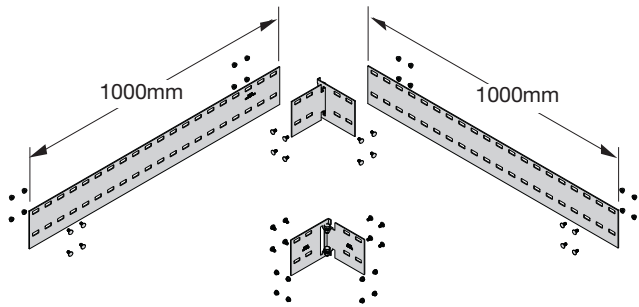
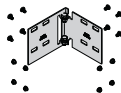
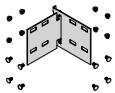

### Splice Kit

Ladder Height mm	Catalog No.
125	LHA125(*)
150	LHA150(*)

### Rail Extension Kit

Ladder Height mm	Catalog No.
125	LRE125(*)-1000
150	LRE150(*)-1000

## Reversing Splice Plates

- For reversing ladder orientation.
- Supplied as one pair with hardware.
- (\*) Insert G or SS6

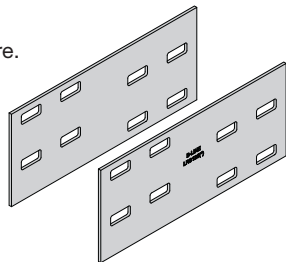

Ladder Height mm	Catalog No.
125	LRS125(*)
150	LRS150(*)

## Splice Hardware

**Catalog No. M10x20 SNCB(\*)**

Square Neck Coach Bolt

**Catalog No. M10 SFHN(\*)**

Serrated Flange Hex Nut

**Catalog No. M10 ELAS(\*)**

Elastic Stop Nut

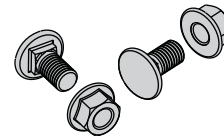

**Finish (\*):** HDG = Hot Dipped Galvanized  
SS6 = Stainless Steel 316

## Heavy Duty Expansion Splice Plates

Heavy Duty Expansion Splice Plates are engineered to eliminate the recommended additional support at each expansion joint where cable ladder systems are utilized. They allow installers to support an expansion joint without additional supports versus the traditional two supports.

Expansion joints are common in long-run outdoor applications where temperature variations result in thermal expansion and contraction of the cable ladder system. The installer using the traditional expansion splice would be required to install two supports, one on either side of the expansion joint. By utilizing the B-Line Heavy Duty Expansion Splice Plate, no additional supports are required.

- NEMA VE 2 Compliant
- Lowest total cost of installation solution
- Wrap-around design supports the side rail on bottom of each ladder section
- Available Offering:
  - Hot dip galvanized steel
  - Stainless steel 316
- Designed for easy installation in a variety of applications
- Supplied in pairs with hardware
- Utilize with B-Line Cable Ladder Systems
  - HPL, SDL, & HDL

Heavy Duty Expansion Splice Plates are one of five key attributes of the B-Line cable ladder system that combine to yield significant opportunities to reduce structural steel supports in heavy industrial applications by up to 66%. To learn more, visit [www.cooperblineline.com/sss](http://www.cooperblineline.com/sss).

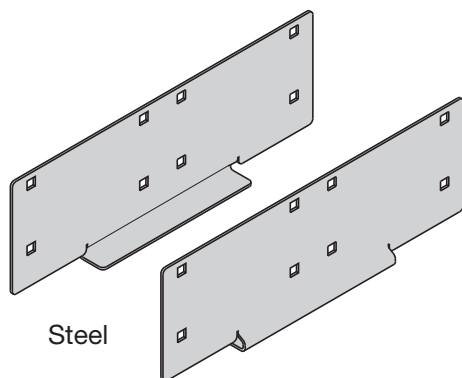

Steel Ladder Height	Catalog No.	
	HDG	SS6
125	LHE125G	LHE125SS6
150	LHE150G	LHE150SS6

All dimensions are in millimeters unless otherwise specified.

# Cable Ladder Accessories

## Tee/Wall Connector

- For field connecting ladder to a wall or to another ladder as a tee.
- Supplied in pairs with hardware.
- (\*) Insert G or SS6

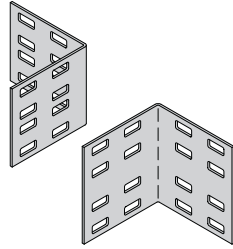

Ladder Height mm	Catalog No.
125	LTC125(*)
150	LTC150(*)

## Bonding Jumper

Use at each expansion splice and where the cable ladder is not mechanically/electrically continuous to ground.

- Sold individually.
- Hardware included.
- Bonding jumper is 406mm long.

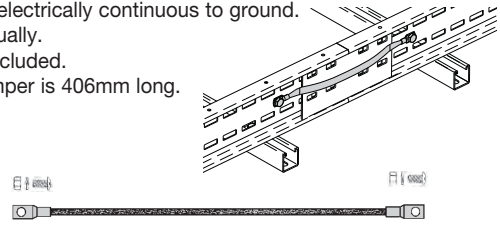

Catalog No.	Copper Wire	Ampacity
99-N1	9 Strands #1	600

## Blind End

- For finished look to end of ladder.
- Supplied as one plate with hardware.
- (\*) Insert G or SS6

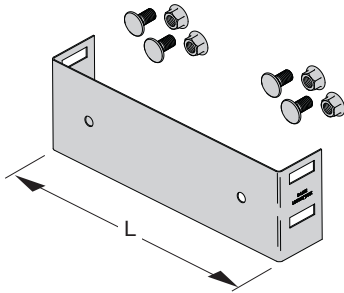

Ladder Height mm	Catalog No.	'L' mm
125	LBE125(*)150	150
	LBE125(*)300	300
	LBE125(*)450	450
	LBE125(*)600	600
	LBE125(*)900	900
150	LBE150(*)150	150
	LBE150(*)300	300
	LBE150(*)450	450
	LBE150(*)600	600
	LBE150(*)900	900

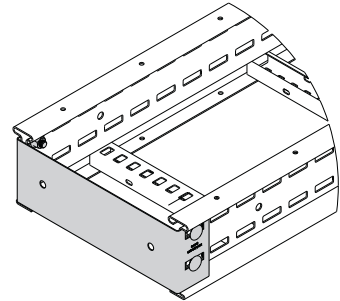

## Ladder Drop-Out

- Specially-designed Ladder Drop-Outs provide a rounded surface with 100mm radius to protect cable as it exits from the cable ladder, preventing damage to insulation. The drop-out will attach to any desired rung.
- Supplied with hardware.
- (\*) Insert G or SS6

Catalog No.	Ladder Width mm
LDO(*)150	150
LDO(*)300	300
LDO(*)450	450
LDO(*)600	600
LDO(*)750	750
LDO(*)900	900

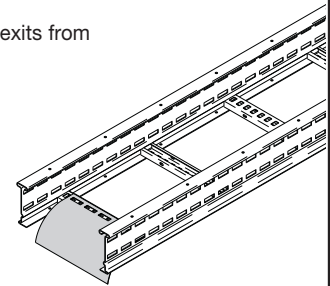
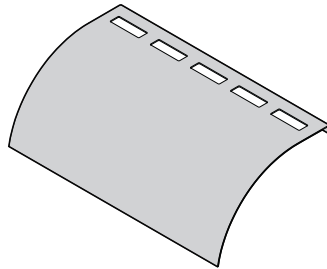

## Threaded Rod (ATR) & Rod Coupling

Loading based on safety factor 5.

See B-Line Strut Systems Catalog for other size and finish options.

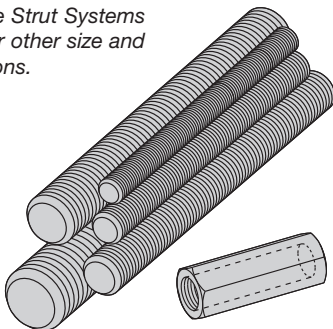

Catalog No. & Size	Threads Size	Recommended Load kN	Wt./30.5m kg
ATR M6	M6	1.32	6.1
ATR M8	M8	2.42	10.7
ATR M10	M10	3.66	15.3
ATR M12	M12	5.35	24.4

## Cable Ladder Clamp/Guide - SDL & HDL Series

- Features a no-twist design.
- Has four times the strength of the traditional design.
- Each side is labelled to ensure proper installation.
- Supplied in pairs without hardware.
- (\*) Insert G or SS6

Patent # RE35479

Catalog No.	Overall Length	Hardware Size
9(*)-1204	38mm	M6
9(*)-1208	57mm	M10
9(*)-1205	57mm	M12

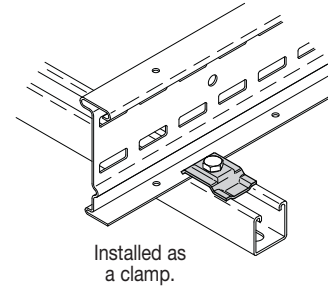
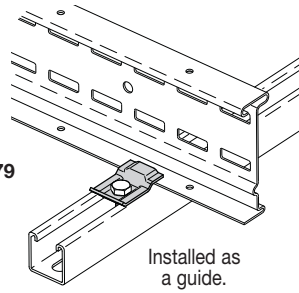

When installing this device as an expansion guide on the outside flange of *Side Rail*, use the Catalog No. **B202** Square Washer (see page 130) in order to properly elevate the guide.

## Cable Ladder Clamp/Guide - HPL Series

- Improves performance - see HPL Series Load Tables below
- Both LHD-121X and LHD-123X are sold in pairs
  - LHD-121X - requires mounting hardware (not included)
  - LHD-123X includes side rail attachment hardware - requires mounting hardware (not included)
- Material: SS6
- Thickness: 6mm
- Patent Pending

Catalog Number	Description	Side Rail Mtg. Hardware	Mounting Hardware
LHD-121X	1-Hole Hold Down Plate	None Required	(1) M12 HHCS
LHD-123X	3-Hole Hold Down Clamp	Includes (2) M10 SNCB & SFHN	(1) M12 HHCS

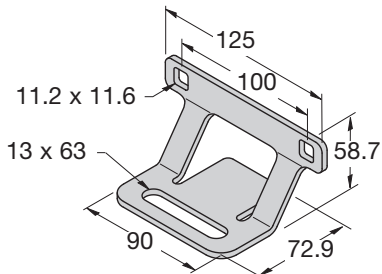
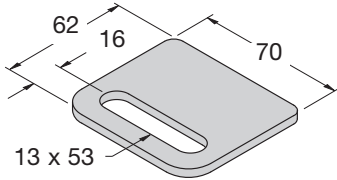

Height	Material	LHD-123X	Span (m)	Loads (kg/m)	LHD-121X	Span (m)	Loads (kg/m)
HPL Series 125mm	SS6		3	345		3	293
			4	166		4	143
			5	99		5	86
			6	90		6	79
HPL Series 150mm	SS6		3	391		3	345
			4	212		4	184
			5	130		5	113
			6	98		6	96

All dimensions are in millimeters unless otherwise specified.

# Cable Ladder Accessories

## Straight Divider

- Standard length: 3000mm (3m) or 1000mm (1m).
- Order catalog number based on loading depth.
- Supplied with mounting hardware.
- Supplied with 99-9982 divider splice.
- (\*) Insert G or SS6

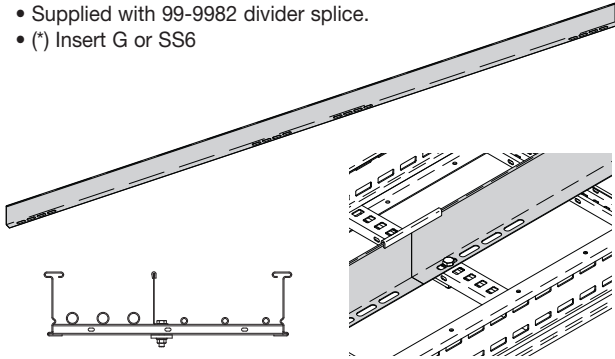

Catalog No.	Side Rail Height mm	Length mm
LSD125(*)-3000	125	3000
LSD150(*)-3000	150	3000

## Bendable Divider

- Horizontal Bend Barriers are flexible in order to conform to any horizontal fitting radius. Cut to length.
- Order catalog number based on loading depth.
- Supplied with mounting hardware.
- Standard length is 1000mm (1m), sold individually.
- Supplied with 99-9982 divider splice.
- (\*) Insert G or SS6

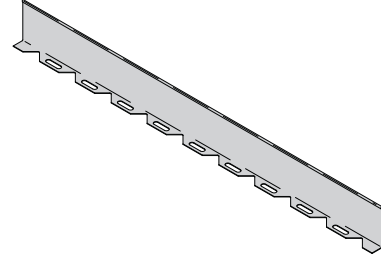

Catalog No.	Side Rail Height mm	Length mm
LBD125(*)-1000	125	1000
LBD150(*)-1000	150	1000

## Vertical Dividers

- Vertical Bend Barriers are preformed to conform to a specific vertical fitting.
- Supplied with mounting hardware and a 99-9982 Divider Splice.
- (\*) Insert G or SS6 for finish
- (\*\*) Insert 30, 45, 60 or 90 for degrees
- (\*\*\*) Insert 300 for 300mm, 600 for 600mm, 900 for 900mm, or 1200 for 1200mm for radius

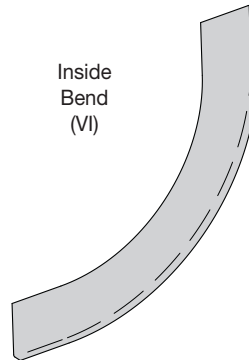

Inside Bend (VI)

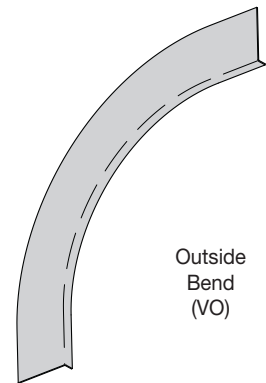

Outside Bend (VO)

Side Rail Height	Catalog No.		Divider Height mm
	Inside Bend	Outside Bend	
125	LID125(*)(**)(***)	LOD125(*)(**)(***)	100
150	LID150(*)(**)(***)	LOD150(*)(**)(***)	125

## Divider Splice

- Plastic splice holds adjoining barrier strips in straight alignment.

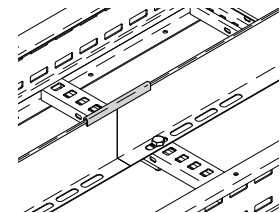
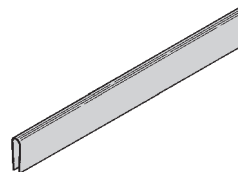

Catalog No.	99-9982
-------------	---------

All dimensions are in millimeters unless otherwise specified.

# Cable Ladder Weight Tables

## HPL Series Cable Ladder

Height	Material	Series		Tray Width					
				150mm	300mm	450mm	600mm	750mm	900mm
125mm	SS6	HPL	kg/m	4.4	4.8	5.3	5.7	6.6	7.1
			Strength to Weight Ratio*	78.4	71.9	65.1	60.5	52.3	48.6
150mm	SS6	HPL	kg/m	4.8	5.3	5.7	6.2	7.0	7.5
			Strength to Weight Ratio*	81.5	73.8	68.6	63.1	55.9	52.1

## SDL & HDL Series Cable Ladder

Height	Material	Series		Tray Width					
				150mm	300mm	450mm	600mm	750mm	900mm
125mm	HDG	SDL	kg/m	5.7	6.2	6.7	7.2	8.4	9.0
			Strength to Weight Ratio*	73.7	67.7	62.7	58.3	50.0	46.7
		HDL	kg/m	7.3	7.8	8.3	8.8	10.0	10.7
			Strength to Weight Ratio*	60.5	56.7	53.3	50.2	44.2	41.3
125mm	SS6	SDL	kg/m	5.3	5.8	6.2	6.7	7.8	8.4
			Strength to Weight Ratio*	83.2	76.0	71.1	65.8	56.5	52.5
		HDL	kg/m	6.8	7.3	7.7	8.2	9.3	9.9
			Strength to Weight Ratio*	67.4	62.7	59.5	55.9	49.2	46.3
150mm	HDG	SDL	kg/m	6.3	6.8	7.3	7.8	9.0	9.6
			Strength to Weight Ratio*	83.3	77.2	71.9	67.3	58.3	54.7
		HDL	kg/m	8.2	8.7	9.2	9.7	10.9	11.5
			Strength to Weight Ratio*	70.4	66.3	62.7	59.5	52.9	50.2
150mm	SS6	SDL	kg/m	5.9	6.3	6.8	7.2	8.4	9.0
			Strength to Weight Ratio*	80.3	75.2	69.7	65.8	56.4	52.7
		HDL	kg/m	7.6	8.1	8.5	9.0	10.1	10.7
			Strength to Weight Ratio*	63.4	59.5	56.7	53.6	47.7	45.0

\* Strength to Weight Ratio determined by dividing 3m span load by weight.  
Weights are for 300mm rung spacing, C-rung, slotted side rail.

To download all ladder weights, visit; [www.cooperblineline.com/iec](http://www.cooperblineline.com/iec)

All dimensions are in millimeters unless otherwise specified.

## Metric Cable Ladder Technical Guide

The technical data contained within this guide is intended to provide the engineer with adequate information to design and specify an efficient and robust cable ladder system. B-Line recommends that the engineer considers the following subjects when designing the cable ladder system which are detailed within the corresponding sections of this guide:

1. Side Rail and Rung Design
2. Materials
3. Finish
4. Corrosion
5. Load Performance Type Tests
6. Environmental Loads
7. Impact
8. Electrical Continuity
9. Free Base Area
10. Thermal Contraction and Expansion
11. Support and Installation Recommendations
12. Cable Restraint

### 1. Side Rail and Rung Design

B-Line cable ladder side rail uses a high performance rolled I-Beam profile. The more complex the structural profile, the higher the strength yielded by the profile. The rolled I-Beam profile provides greater performance than standard C-section and complex C-section profiles commonly used in cable ladder designs. Due to the higher performance provided by the I-Beam it allows for a reduced material gauge thickness, reducing product weight.

The slotted side rail is designed to provide equally spaced slots along the entire length. These allow for the installer to field cut and modify the standard length and connect new lengths and/or fittings with a standard splice plate without the need for on-site drilling. The slots also allow the designer and installer to use the slots for the attachment of additional accessories and equipment, again without the need to drill the cable ladder. In addition, the slots result in a lighter weight ladder with increased ventilation.



## 2. Materials

MATERIAL	STANDARD	GRADE
Steel	BS EN 10025-2 : 2004	S275 or equivalent
Stainless Steel	BS EN 10088-2 : 2005	1.4404 (AISI 316)

### Steel Grade S275:

B-Line cable ladder is manufactured from continuously roll formed Grade S275 structural steel or equivalent. Use of a structural grade steel guarantees the material to meet the minimum structural and chemical properties specified in the BS EN 10025-2 : 2004 standard.

### Steel Grade S275:

Typical Chemical Composition												
Name	Number	Deoxidation Method	C % For thickness range			Si max	Mn max	P max	S max	N max	Cu max	Other
			=< 16	> 16 =<40	>40	%	%	%	%	%	%	%
S275	1.0145	FF	0,21	0,21	0,21	-	1,6	0,035	0,035	-	0,60	-

Typical Mechanical Properties															
Name	Number	ReH Minimum Yield strength (MPa ) for nominal thickness(mm)								R m (MPa) for nominal thickness (mm)					
		<16	=>16	>40	>63	>80	>100	>150	>200	>250	<3	=>3	>100	>150	>250
			=< 40	=< 63	=< 80	=< 100	=< 150	=< 200	=< 250	=< 400		=< 100	=< 150	<= 250	=< 400
S275	1.0145	275	265	255	245	235	225	215	205	195	430-580	410-560	400-540	380-540	380-540

## Stainless Steel Grade 1.4404 (AISI 316L):

B-Line cable ladder is manufactured from continuously roll formed Grade 1.4404 (AISI 316L) stainless steel. Grade 1.4404 is a non-magnetic stainless steel and part of the “austenitic” group of stainless steels. It is designed to withstand corrosive atmospheres, low and high ambient and operating temperatures. Grade 1.4404 is a superior grade of stainless steel due to it containing molybdenum. This enhances its resistance to corrosion and makes it appropriate for use in marine salt laden saliferous environments. The importance of using Grade 1.4404 (AISI 316L) relates to the corrosion resistance of the steel after welding. Stainless steel resists corrosion because it forms an impervious passive oxide layer on its surface which forms when oxygen is present. When stainless steel is welded it may lead to a chromium carbide to precipitate at the grain boundaries, depleting the chromium within the austenite and preventing the passive oxide layer from forming. Due to the grain boundaries being small and highly anodic, a rapid corrosion can occur. This process can be prevented by using stainless steels with a carbon content of less than 0.03%. Grade 1.4404 typically has less than 0.03% carbon content.

There are a number of important factors that can make the use of stainless steel imperative. These factors can include long term maintenance costs, corrosion resistance, aesthetic appearance, and ambient operating temperature. Grade 1.4404 stainless steel exhibits stable structural properties such as yield strength and high creep strength at lowered and elevated ambient operating temperatures.

B-Line cable ladder is welded using a stainless steel welding wire to ensure each weldment exhibits the same corrosion resistance as the base metal. Localized staining in the weld area/heat effected zone may occur when exposed to severe corrosive environments. The shielding gases and low carbon materials used in our welding processes minimise carbon contamination during welding to reduce staining and stress corrosion.

## Stainless Steel Grade 1.4404 (AISI 316L):

Typical Chemical Composition													
Name	Number	C	Si	Mn	P max.	S	N	Cr	Cu	Mo	Nb	Ni	Others
Standard Grades													
X2CrNiMo17-12-2	1.4404	≤0,030	≤1,00	≤2,00	0,045	≤0,015	≤0,11	16,5-18,5	-	2,00-2,50	-	10,0-13,0	-

Austenitic steels in solution annealed condition

Typical Mechanical Properties						
Name	Number	Product Form	Thickness max	R <sub>p0.2</sub>	R <sub>m</sub>	A
			mm	MPa	MPa	%
Standard grades						
X2CrNiMo17-12-2	1.4404	C	8	240	530-680	40
		H	13,5	220	530-680	40
		P	75	220	520-670	45
		H	13,5	220	530-730	35
		P	75	220	520-720	35

## 3. Finish

### Zinc Coatings

Zinc protects steel in two ways. First it protects the steel as a coating and second as a sacrificial anode to repair bare areas such as cut edges, scratches, and gouges. The corrosion protection of zinc is directly related to its thickness and the environment. This means a .2 mil coating will last twice as long as a .1 mil coating in the same environment.

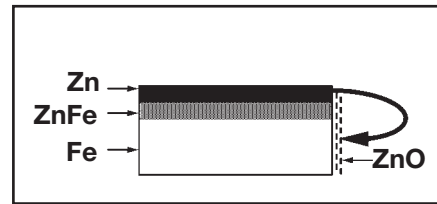

Galvanizing also protects cut and drilled edges.

### Hot Dip Galvanized After Fabrication

(Hot dip galvanized or batch hot dip galvanized)

Hot Dip Galvanized After Fabrication cable ladder products are fabricated from steel and then completely immersed in a bath of molten zinc. A metallic bond occurs resulting in a zinc coating that completely coats all surfaces, including edges and welds.

Another advantage of this method is coating thickness. Cable ladders hot dip galvanized after fabrication to provide an average minimum zinc coating thickness in accordance with BS EN ISO 1461. The zinc thickness is controlled by the amount of time each part is immersed in the molten zinc bath as well as the speed at which it is removed. The term "double dipping" refers to parts too large to fit into the galvanizing kettle and, therefore, must be dipped one end at a time. It does not refer to extra coating thickness.

The layer of zinc which bonds to steel provides a dual protection against corrosion. It protects first as an overall barrier coating. If this coating happens to be scratched or gouged, zinc's secondary defense is called upon to protect the steel by galvanic action.

Hot dip galvanizing after fabrication is recommended for prolonged outdoor exposure and will protect steel for many years in most outdoor environments and in many aggressive industrial environments .

## 4. Corrosion

IEC 61357 : 2006 section 6.5.2, Table 1 "classification for resistance against corrosion" defines the classification class of various materials and finishes used in the manufacture and supply of cable ladder systems against resistance to corrosion.

In accordance with this classification table, B-Line cable ladder can be supplied as to meet the following classifications:

Steel HDG : Class 6

Stainless Steel 1.4404 : Class 9B

Stainless Steel 1.4404 : Class 9D

### Stainless Steel

Several important conditions could make the use of stainless steel imperative. These include long term maintenance costs, corrosion resistance, appearance and locations where product contamination is undesirable. Stainless steel exhibits stable structural properties such as yield strength and high creep strength at elevated temperatures.

## 5. Load Performance Type Tests

B-Line cable ladder has been performance load tested in full compliance with the requirements of IEC 61537 : 2006 standard titled “Cable Management - Cable Tray Systems and Cable Ladder Systems” and load and deflection results published within this catalog are based upon these tests. Type load tests have been witnessed by DNV independent third party inspectorates. We recommend that the specifying engineer insists upon independent third party certificates confirming compliance to the IEC standard and published load tables within the manufacturer’s catalog.

B-Line has tested our cable ladder to the following type tests detailed within the IEC 61537 standard:

### Type Test - II

- L = Intermediate Span
- S = Splice Location (Mid-span)
- UDL = Uniform Distributed Load
- A,B,C = Support Positions
- D = Deflection Measuring Point (Mid-span)

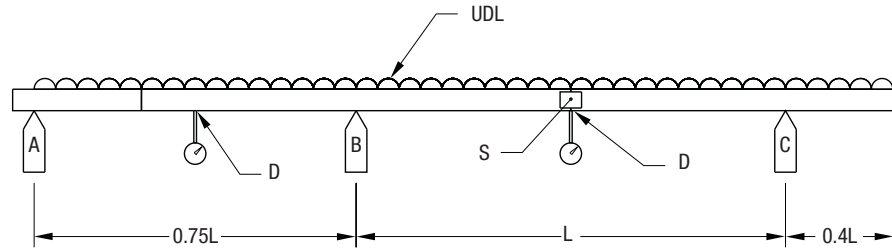

## 6. Environmental Loads

### Wind Loads

Wind loads need to be considered for all outdoor cable ladder installations. The most severe loading to be considered is impact pressure normal to the cable ladder side rails.

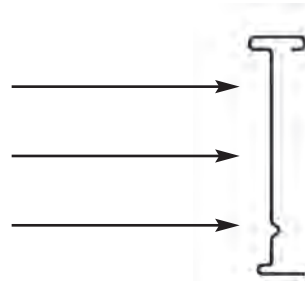

The impact pressure corresponding to several wind velocities are given below in Table 1.

**Table 1**  
**Impact Pressures**

V (km/h)	P (kg/m <sup>2</sup> )	V (km/h)	P (kg/m <sup>2</sup> )	V (km/h)	P (kg/m <sup>2</sup> )
24	2.83	104	52.70	184	164.94
32	4.98	112	61.00	192	179.58
40	7.81	120	70.27	200	195.20
48	11.22	128	80.03	208	211.30
56	15.27	136	90.28	216	227.41
64	19.96	144	101.02	224	244.49
72	25.28	152	112.73	232	262.54
80	31.18	160	124.93	240	281.09
88	37.72	168	137.62		
96	44.94	176	150.79		

V= Wind Velocity      P= Impact Pressure

Note: These values are for an air density of 16.02 kg/m<sup>3</sup> corresponding to a temperature of 15.5° C and barometric pressure of 10,355 kg/m<sup>2</sup>.

**Example Calculation:** Side load for 150mm side rail with 160 km/h wind

$$\frac{124.93 \times 150}{1000} = 18.74 \text{ kg/m}$$

When covers are installed on outdoor cable ladders, another factor to be considered is the aerodynamic effect which can produce a lift strong enough to separate a cover from a ladder. Wind moving across a covered ladder (see detail 2) creates a positive pressure inside the ladder and a negative pressure above the cover. This pressure difference can lift the cover off the ladder.

Detail 2

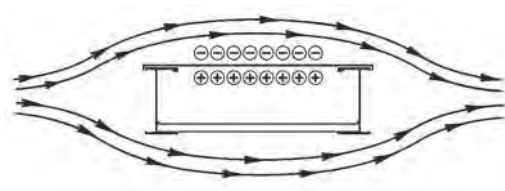

B-Line recommends the use of high performance cover clamps when covered ladders are installed in an area where strong winds occur.

## Ice Loads

Glaze ice is the most commonly seen form of ice build-up. It is the result of rain or drizzle freezing on impact with an exposed object. Generally, only the top surface (or the cover) and the windward side of a cable ladder system is significantly coated with ice. The maximum design load to be added due to ice should be calculated as follows:

$$LI = \left( \frac{W \times TI}{1,000,000} \right) \times DI \text{ where;}$$

LI= Ice Load (kg/m)

W= Cable Tray Width (mm)

TI= Maximum Ice Thickness (mm)

DI= Ice Density = 913 kg/m<sup>3</sup>

the maximum ice thickness will vary depending on location. A thickness of 12mm can be used as a conservative standard.

### Example Calculation:

Ice Loads for 600mm wide tray with 12mm thick ice;

$$\frac{600 \times 12}{1,000,000} \times 913 = 6.57 \text{ kg/m}$$

## Snow Loads

Snow is measured by density and thickness. The density of snow varies almost as much as its thickness. The additional design load from snowfall should be determined using the building codes which apply for each installation.

## 7. Impact

B-Line cable ladder conforms to an Impact Test Value of 50J based on the IEC 61537:2006, Section 10.9.

## 8. Electrical Continuity

Electrical continuity testing of B-Line cable ladder was conducted in accordance with IEC 61357 : 2006, section 11.1.2 and results in an electrical impedance less than 50milli ohms across the joint and 5 milli ohms per metre without a joint.

## 9. Free Base Area

In accordance with IEC 61537; 2006, section 6.8, Table 5 “Free Base Area Classification” B-Line cable ladder has a classification of ‘Y’ on standard 300mm rung spacing and a calculated free base area of 86%.

## 10. Thermal Contraction and Expansion

It is important that thermal contraction and expansion be considered when installing cable ladder systems. The length of the straight cable tray runs and the temperature differential govern the number of expansion splice plates required (see Table 2 below).

The cable ladder should be anchored at the support nearest to its midpoint between the expansion splice plates and secured by expansion guides at all other support locations (see Figure 1). The cable ladder should be permitted longitudinal movement in both directions from that fixed point. When used, covers should be overlapped at expansion splices.

Accurate gap settings at the time of installation are necessary for the proper operation of the expansion splice plates. The following procedure should assist the installer in determining the correct gap: (see Figure 2)

- 1 Plot the highest expected metal temperature on the maximum temperature line.
- 2 Plot the lowest expected metal temperature on the minimum temperature line.
- 3 Draw a line between the maximum and minimum points.
- 4 Plot the metal temperature at the time of installation to determine the gap setting.

Figure 1

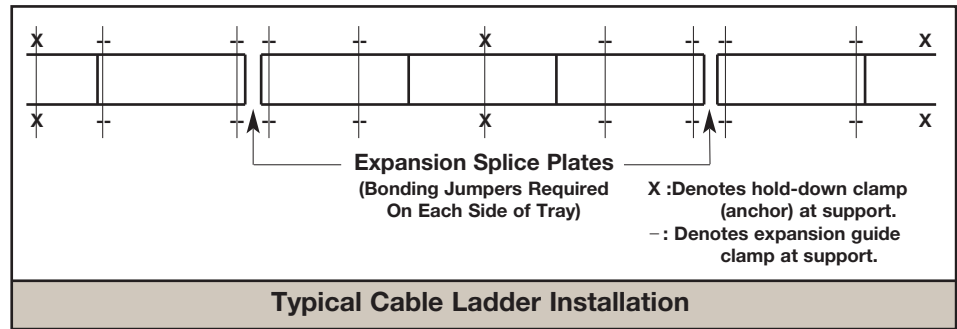

Figure 2

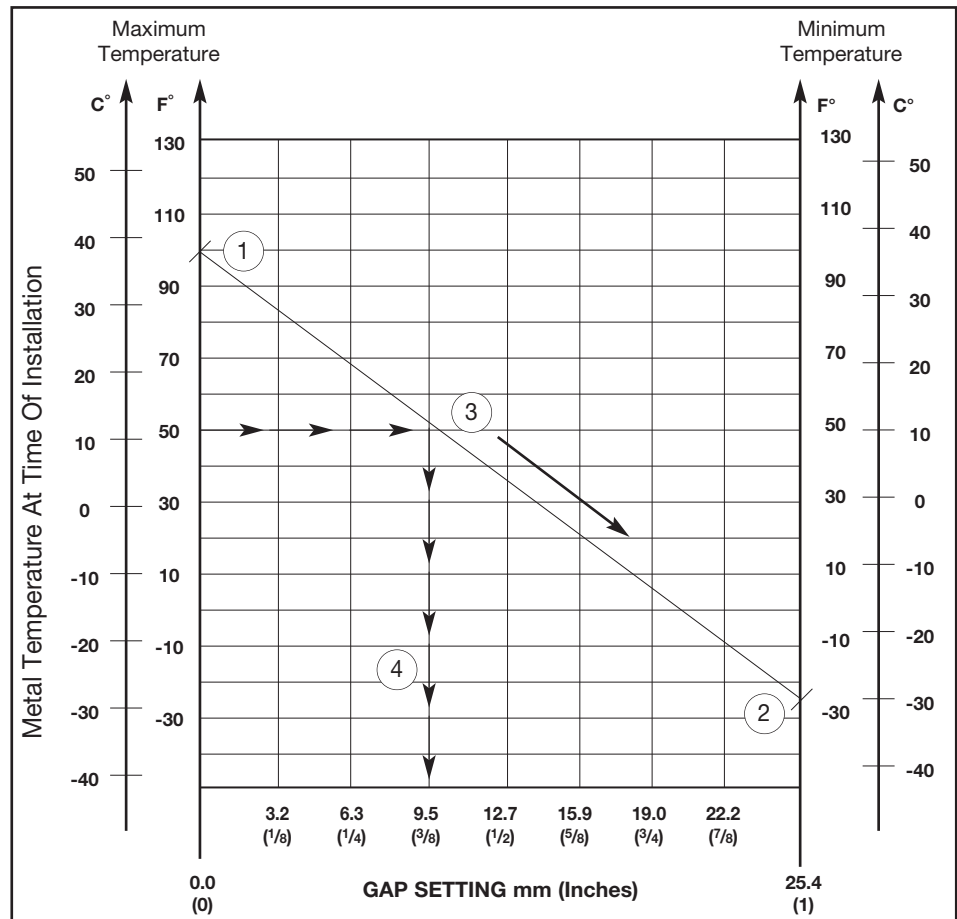

Table 2

Maximum Spacing Between Expansion Joints For 25mm Movement							
Temperature Differential		Steel		Stainless Steel 304		Stainless Steel 316	
°C	°F	m	Feet	m	Feet	m	Feet
13.9	25	156.0	512	105.7	347	115.5	379
27.8	50	78.0	256	53.0	174	57.6	189
41.7	75	52.1	171	35.4	116	38.4	126
55.6	100	39.0	128	26.5	87	29.0	95
69.4	125	31.1	102	21.0	69	23.2	76
83.3	150	25.9	85	17.7	58	19.2	63
97.2	175	22.2	73	15.2	50	16.4	54

Note: every pair of expansion splice plates requires two earth continuity connectors for grounding continuity.

## 11. Support and Installation Recommendations

### Deflection

Deflection in a cable ladder system is primarily an aesthetic consideration. When a cable ladder system is installed in a prominent location, a maximum simple beam deflection of 1/100 of support span can be used as a guideline to minimize visual deflection.

There are two typical beam configurations: simple beam and continuous beam.

An example of a simple beam is a single straight section of cable ladder supported, but not fastened at either end. When the ladder is loaded the cable ladder is allowed to flex. Simple beam support is seldom used in field installations.

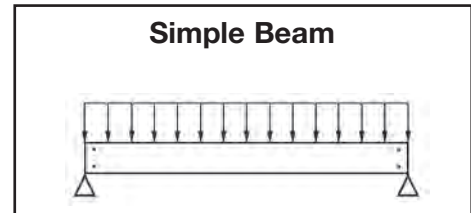

Continuous beam is the beam configuration most commonly used in cable ladder installations. An example of this configuration is where cable ladders are installed across several supports to form a number of spans. The continuous beam possesses traits of both simple and fixed beams. When equal loads are applied to all spans simultaneously, the counter balancing effect of the loads on both sides of a support restricts the movement of the cable ladder at the support. The effect is similar to that of a fixed beam. The end spans behave substantially like simple beams. When cable ladders of identical design are compared, the continuous beam installation will typically have approximately half the deflection of a simple beam of the same span. The following factors should be considered when addressing cable ladder deflection:

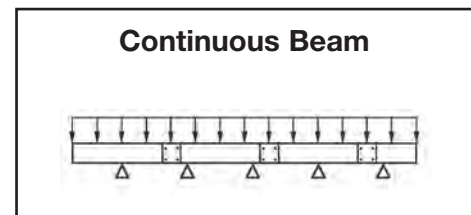

1. Deflection in a cable ladder system can be reduced by decreasing the support span, or by using a taller or stronger cable ladder.
2. Economic consideration must be given when addressing cable deflection criteria. Eliminating deflection can mean purchasing a stronger ladder at higher cost.
3. The location of splices in a continuous span will affect the deflection of the cable ladder system. The splices should be located at points of minimum stress whenever practical. B-Line recommends the following for splice installation:

Straight section lengths should be equal to or greater than the span length to ensure not more than one splice between supports.

See the figures below for splicing configuration samples.

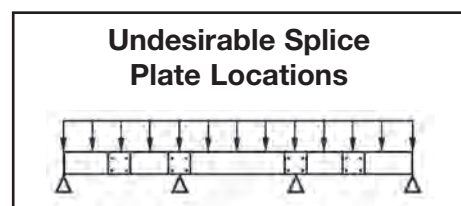
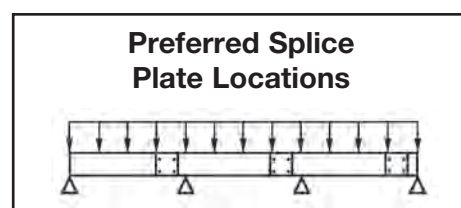
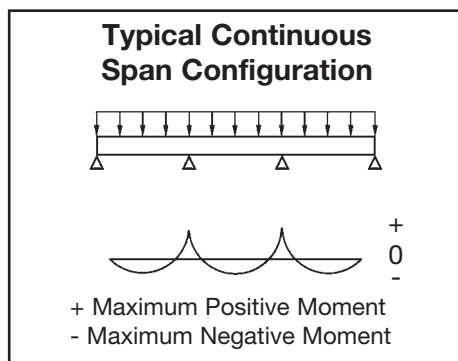

# Technical Guide

## Future Expansion Requirements

One of the many features of cable ladder is the ease of adding cables to an existing system. Future expansion should always be considered when selecting a cable ladder, and allowance should be made for additional fill area and load capacity. A minimum of 50% expansion allowance is recommended.

## Transit Limitations

Consideration should be given to the space available for moving the cable ladder from delivery to its final installation location. Shorter cable ladder allows for more maneuverability in tight spaces.

## Installation

Shorter cable ladder lengths are typically easier to maneuver on the job site during installation. Two people may be needed to manipulate longer cable ladder sections, while shorter sections might be handled by one person. Although longer cable ladder lengths are more difficult to maneuver, they can reduce installation time due to the fact that there are fewer splice connections. This trade-off should be evaluated for each set of job site restrictions.

<b>WARNING!</b> Do not use as a walkway, climbing ladder or support for personnel. Use only as a mechanical support for cables & tubing.		
Catalog Number: 125G300CA20NLHB-0600-90R0600	Cable Ladder Horizontal Bend	U
Sales Order: 9465565 0010	Piece 001 of 999	<b>COOPER B-Line</b> www.cooperbline.com
Mark Number: Item Mark # 123456	Ship Date: 01/11/2011	 123456789012345
Purchase Order: Customer PO 123456		

## 12. Cables and Cable Restraint

### Type of Cable

In general, small, highly flexible cables should be installed in cable ladders with close rung spacing of 200mm or less. Larger, less flexible cables are typically installed in cable ladders having 300mm rung spacing. Cable ladders having rung spacing greater than 300mm should be used for very large, stiff cables to reduce cost and facilitate cable drop-outs.

### Cable Exposure

Many cable jackets are manufactured to withstand the environment without additional protection, favoring the use of the cable ladder. Cable jackets should be evaluated during project design for suitability in the project application.

### Cable Attachment

A major advantage of cable ladder is the freedom of entry and exit of the cables. Another advantage of cable ladder is the ability to secure cables in the cable ladder. With standard rungs, the cables may be attached with either cable ties or cable clamps. Cable attachment is particularly important on vertical runs or when the ladder is installed on its side. Ladder rung spacing should be chosen to provide adequate cable attachment points while allowing the cables to exit the system.

### Cable Flexibility

The proper bend radius for cable ladder fittings is usually determined by the bend radius and stiffness of the cables to be installed. Typically, the cable manufacturer will recommend a minimum bend allowance for each cable. The fitting radius should be equal to or larger than the minimum bend radius of the largest cable which may ever be installed in the system. When several cables are to be installed in the same cable ladder, a larger bend radius may be desirable to ease cable installation.

### Space Limitations

The overall dimensions for a cable ladder fitting will increase as the bend radius increases. Size and cost make the smallest acceptable fitting radius most desirable. When large radius fittings are required, the system layout must be designed to allow adequate space.

**The following factors should be considered when determining the appropriate cable ladder system.**

#### Material & Finish

- Standards Available
- Corrosion
- Thermal Contraction and Expansion
- Installation Considerations and Electrical Grounding Capacity

#### Strength

- Environmental Loads
- Concentrated Loads
- Support Span
- Deflection
- Rung/Trough Data
- Load Capacity
- Cable Data

#### Width & Available Loading Depth

- Cable Diameter
- Allowable Cable Fill
- Barrier Requirements
- Future Expansion Requirements
- Space Limitations

#### Length

- Lengths Available
- Support Spans (Not to exceed the length of straight sections)
- Space Limitations
- Installation

#### Loading Possibilities

- Power Application
- Data/Communication Cabling
- Other Factors to Consider

#### Bottom Type

- Type of Cable
- Cost vs. Strength
- Cable Exposure
- Cable Attachment

#### Fitting Radius

- Cable Flexibility
- Space Limitations

# Perforated & Solid Bottom Cable Tray - Northern Asia

Straight Sections See pages 55 - 58  
Straight Section Covers See page 75 - 76



Northern Asia  
Perf & Solid Cable Tray

# Perforated & Solid Bottom Cable Tray - Northern Asia

Accessories

See pages 59 - 62



Fittings See pages 63 - 74

Fitting Covers See pages 77 - 78



Perf & Solid Bottom Tray  
Northern Asia

All dimensions are in millimetres unless otherwise specified.

# Cable Tray - Straight Sections - Northern Asia

## Straight Section Part Numbering - 25mm Height

Example: **P 025 V C P 15 SS - 200 - 3000 - NA** (Northern Asia)

Tray Type	Height	Bottom Type	Return Flange Type	Material	Thickness	Type	Width	Length
<b>P =</b> (Perforated & Solid Cable Tray)	<b>025 =</b> 25mm	<b>S = Solid</b> <b>V = Perforated</b>	<b>C = 90°</b>	<b>P = Pre-Galv</b> <b>G = HDGAF</b> <b>SS6 = Stainless Type 316</b>	<b>10 * = 1.0mm</b> <b>15 = 1.5mm</b> <b>20 = 2.0mm</b>	<b>SS =</b> Straight Section	<b>050 = 50mm</b> <b>100 = 100mm</b> <b>150 = 150mm</b> <b>200 = 200mm</b> <b>300 = 300mm</b> <b>400 = 400mm</b> <b>500 = 500mm</b> <b>600 = 600mm</b>	<b>3000 =</b> 3000mm

\* 1.0mm thickness is only available in widths up to and including 300 (300mm).

Splice plates not supplied with straight sections. Order standard splice plates separately from page 59. One (1) pair required to connect to system.

### 90° Return Flange (C) with Perforated Bottom (V)

Notes:

Perforated slot dimensions and patterns may vary depending on tray size and type.

The 180° return flange is not available on 025 tray heights.

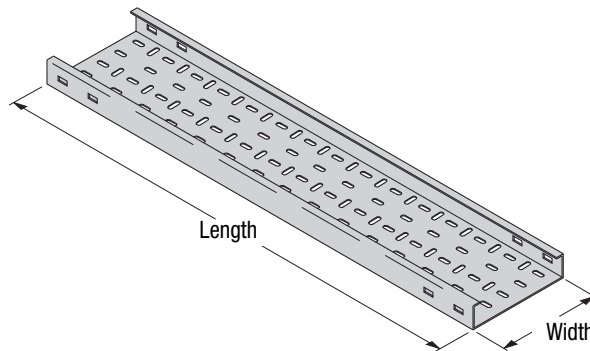

## Perforated & Solid Cable Tray Dimensional Drawing - Tray Height 25mm

### 90° Return Flange (C)

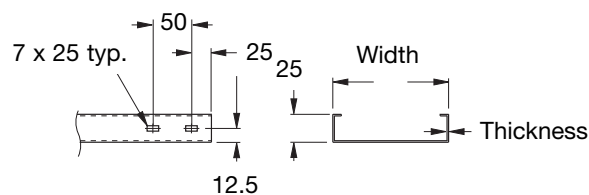

All dimensions are in millimetres unless otherwise specified.

# Cable Tray - Straight Sections - Northern Asia

## Straight Section Part Numbering - 50mm Height

Example: **P 050 V C P 15 SS - 200 - 3000 - NA** (Northern Asia)

Tray Type	Height	Bottom Type	Return Flange Type	Material	Thickness	Type	Width	Length
<b>P =</b> (Perforated & Solid Cable Tray)	<b>050 =</b> 50mm	<b>S = Solid</b> <b>V = Perforated</b>	<b>R = 180°</b> <b>C = 90°</b>	<b>P = Pre-Galv</b> <b>G = HDGAF</b> <b>SS6 = Stainless Type 316</b>	<b>10 * = 1.0mm</b> <b>15 = 1.5mm</b> <b>20 = 2.0mm</b>	<b>SS =</b> Straight Section	<b>050 = 50mm</b> <b>100 = 100mm</b> <b>150 = 150mm</b> <b>200 = 200mm</b> <b>300 = 300mm</b> <b>400 = 400mm</b> <b>500 = 500mm</b> <b>600 = 600mm</b> <b>900 = 900mm</b>	<b>3000 =</b> 3000mm

\* 1.0mm thickness is only available in widths up to and including 300 (300mm).

Splice plates not supplied with straight sections. Order standard splice plates separately from page 59. One (1) pair required to connect to system.

### 180° Return Flange (R) with Solid Bottom (S)

### 90° Return Flange (C) with Perforated Bottom (V)

Note:

Perforated slot dimensions and patterns may vary depending on tray size and type.

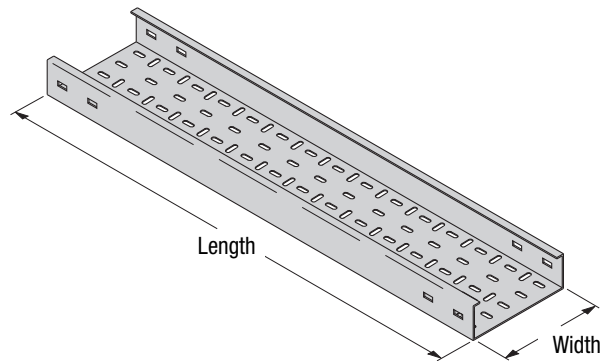
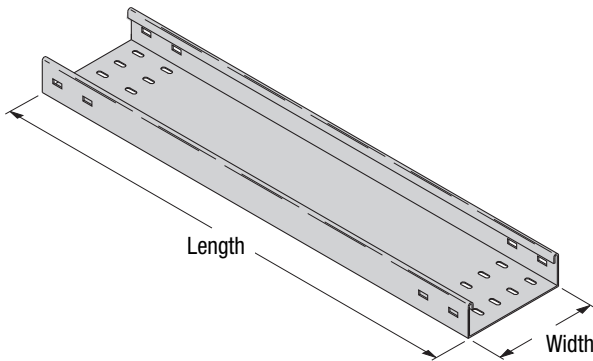

### Perforated & Solid Cable Tray Dimensional Drawing - Tray Height 50mm

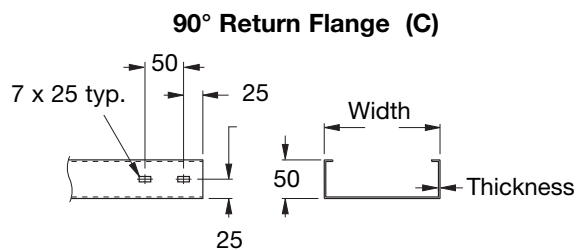
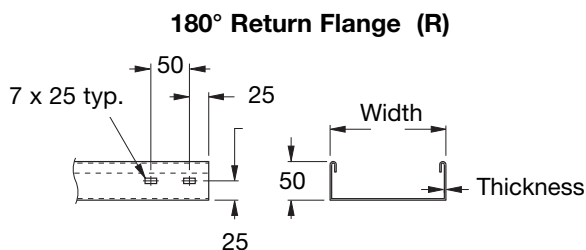

All dimensions are in millimetres unless otherwise specified.

# Cable Tray - Straight Sections - Northern Asia

## Straight Section Part Numbering - 75mm Height

Example: **P 075 V C P 15 SS - 200 - 3000 - NA** (Northern Asia)

Tray Type	Height	Bottom Type	Return Flange Type	Material	Thickness	Type	Width	Length
<b>P =</b> (Perforated & Solid Cable Tray)	<b>075 =</b> 75mm	<b>S = Solid</b> <b>V = Perforated</b>	<b>R = 180°</b> <b>C = 90°</b>	<b>P = Pre-Galv</b> <b>G = HDGAF</b> <b>SS6 = Stainless Type 316</b>	<b>10 * = 1.0mm</b> <b>15 = 1.5mm</b> <b>20 = 2.0mm</b>	<b>SS =</b> Straight Section	<b>100 = 100mm</b> <b>150 = 150mm</b> <b>200 = 200mm</b> <b>300 = 300mm</b> <b>400 = 400mm</b> <b>500 = 500mm</b> <b>600 = 600mm</b> <b>900 = 900mm</b>	<b>3000 =</b> 3000mm

\* 1.0mm thickness is only available in widths up to and including 300 (300mm).

Splice plates not supplied with straight sections. Order standard splice plates separately from page 59. One (1) pair required to connect to system.

Perf & Solid Bottom Tray Northern Asia

### 180° Return Flange (R) with Solid Bottom (S)

### 90° Return Flange (C) with Perforated Bottom (V)

Note:

Perforated slot dimensions and patterns may vary depending on tray size and type.

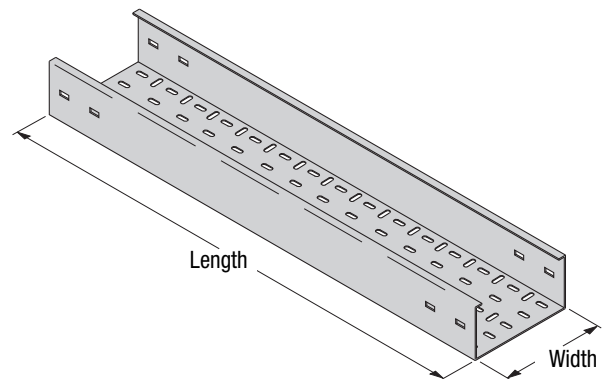
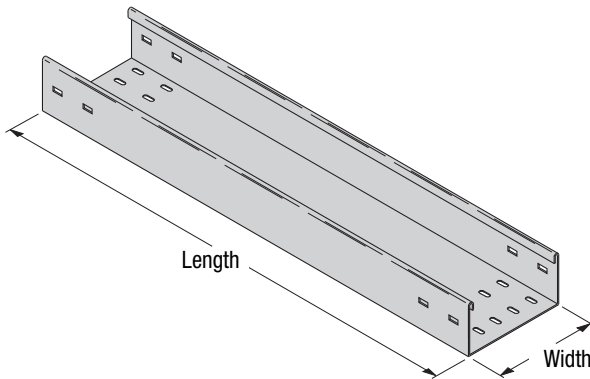

### Perforated & Solid Cable Tray Dimensional Drawing - Tray Height 75mm

#### 180° Return Flange (R)

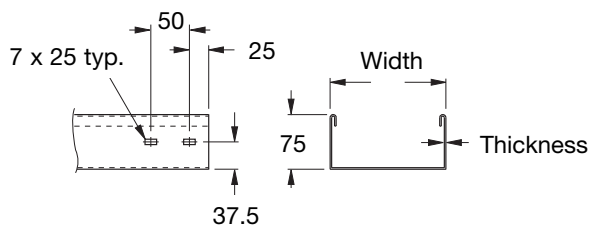

#### 90° Return Flange (C)

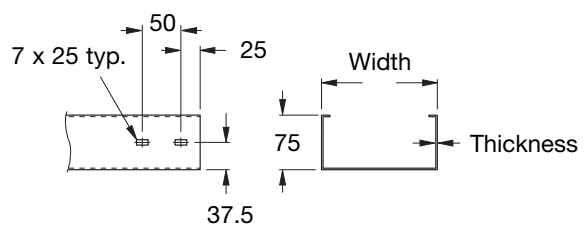

All dimensions are in millimetres unless otherwise specified.

# Cable Tray - Straight Sections - Northern Asia

## Straight Section Part Numbering - 100mm Height

Example: **P 100 V C P 15 SS - 200 - 3000 - NA** (Northern Asia)

Tray Type	Height	Bottom Type	Return Flange Type	Material	Thickness	Type	Width	Length
<b>P =</b> (Perforated & Solid Cable Tray)	<b>100 =</b> 100mm	<b>S = Solid</b> <b>V = Perforated</b>	<b>R = 180°</b> <b>C = 90°</b>	<b>P = Pre-Galv</b> <b>G = HDGAF</b> <b>SS6 = Stainless Type 316</b>	<b>10 * = 1.0mm</b> <b>15 = 1.5mm</b> <b>20 = 2.0mm</b>	<b>SS =</b> Straight Section	<b>100 = 100mm</b> <b>150 = 150mm</b> <b>200 = 200mm</b> <b>300 = 300mm</b> <b>400 = 400mm</b> <b>500 = 500mm</b> <b>600 = 600mm</b> <b>900 = 900mm</b>	<b>3000 =</b> 3000mm

\* 1.0mm thickness is only available in widths up to and including 300 (300mm).

Splice plates not supplied with straight sections. Order standard splice plates separately from page 59. One (1) pair required to connect to system.

### 180° Return Flange (R) with Solid Bottom (S)

### 90° Return Flange (C) with Perforated Bottom (V)

Note:

Perforated slot dimensions and patterns may vary depending on tray size and type.

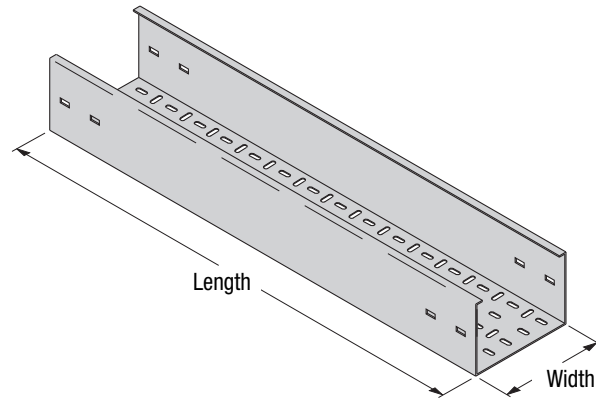
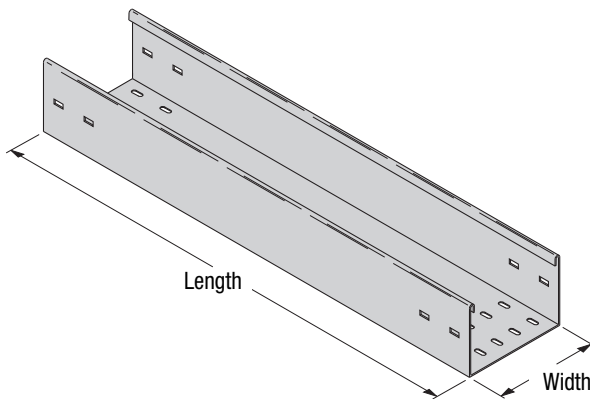

## Perforated & Solid Cable Ladder Dimensional Drawing - Side Rail Height 100mm

### 180° Return Flange (R)

### 90° Return Flange (C)

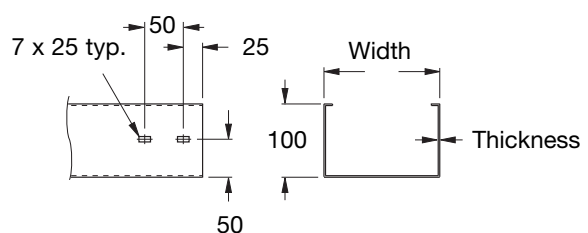
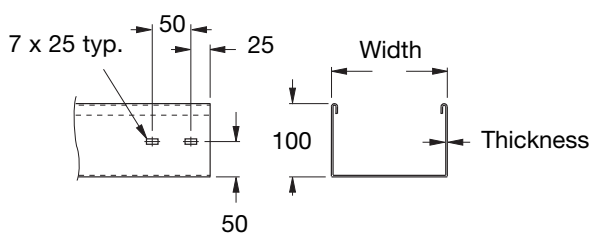

All dimensions are in millimetres unless otherwise specified.

# Cable Tray - Splice Plates & Cover Clamps - Northern Asia

## Bottom Splice Plates (Mounted on bottom of tray to help stabilize tray connections)

(Sold Individually With Hardware)

- \*\* Insert P for Pre-Galvanized, G for Hot Dip Galvanized, SS6 for Stainless Steel 316

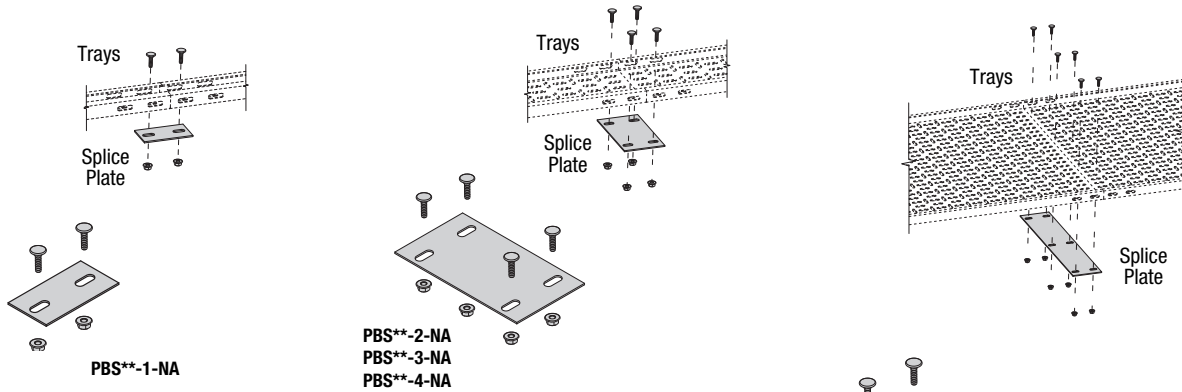

Part Number	Tray Widths	Plate Width	Number of Holes
PBS**-1-NA	50	44	2
PBS**-2-NA	100	94	4
PBS**-3-NA	150 - 300	144	4
PBS**-4-NA	400 - 500	194	4
PBS**-5-NA	600	394	6
PBS**-6-NA	900	594	6

## Side Splice Plates (Mounted outside of tray)

(Sold in Pairs With Hardware)

- \*\* Insert P for Pre-Galvanized, G for Hot Dip Galvanized, SS6 for Stainless Steel 316

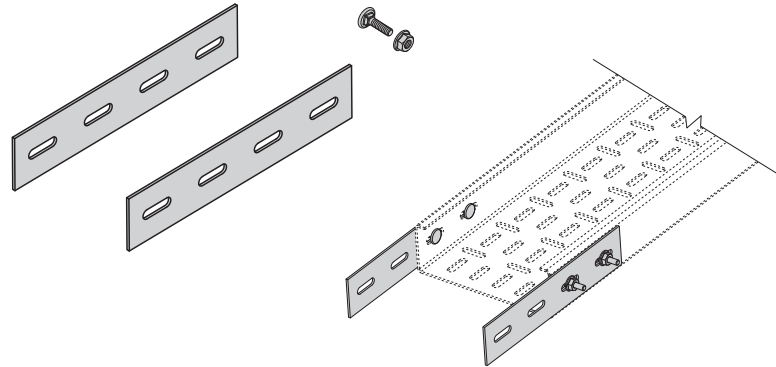

Part Number	Tray Height
PSP025**-NA	25
PSP050**-NA	50
PSP075**-NA	75
PSP100**-NA	100

## Angled Bottom Splice Plates (Mounted outside of tray)

(Sold in Pairs With Hardware)

- \*\* Insert P for Pre-Galvanized, G for Hot Dip Galvanized, SS6 for Stainless Steel 316

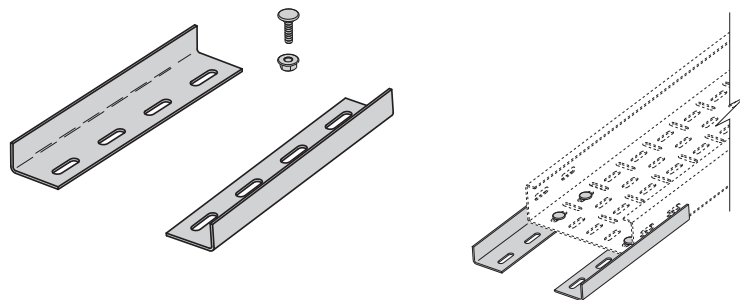

Part Number	Tray Height
PAS**-NA	25, 50, 75, 100

# Cable Tray - Splice Plates & Cover Clamps - Northern Asia

## Expansion Splice Plates (Mounted outside of tray)

(Sold in Pairs With Hardware)

- \*\* Insert P for Pre-Galvanized, G for Hot Dip Galvanized, SS6 for Stainless Steel 316

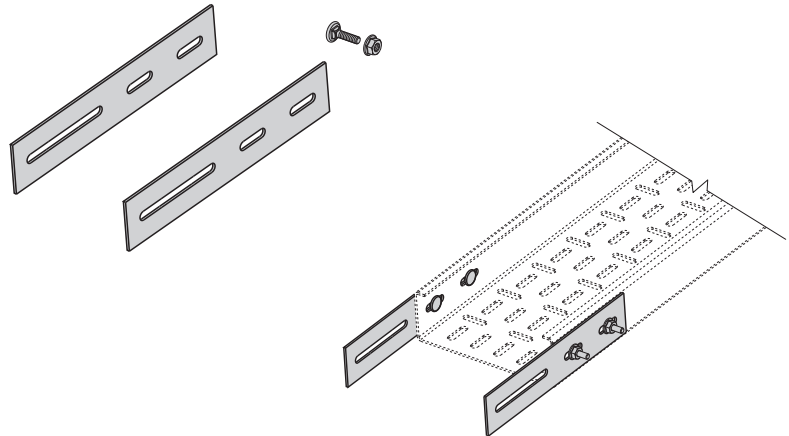

Part Number	Tray Height
PEP025**-NA	25
PEP050**-NA	50
PEP075**-NA	75
PEP100**-NA	100

## Vertical Adjustable Splice Plates (Mounted outside of tray)

(Sold in Pairs With Hardware)

- \*\* Insert P for Pre-Galvanized, G for Hot Dip Galvanized, SS6 for Stainless Steel 316

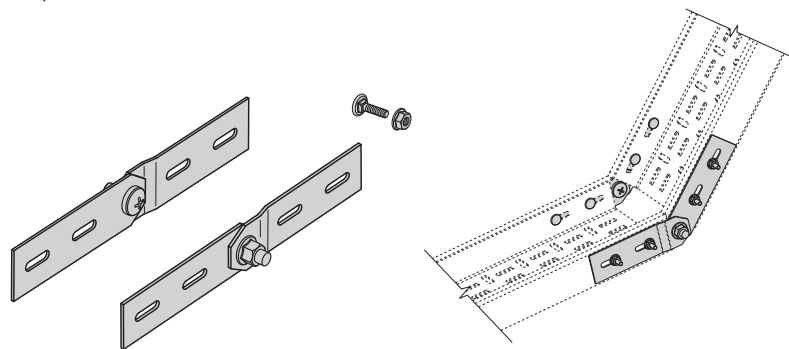

Part Number	Tray Height
PVA025**-NA	25
PVA050**-NA	50
PVA075**-NA	75
PVA100**-NA	100

## Horizontal Adjustable Splice Plates (Mounted outside of tray)

(Sold in Pairs With Hardware)

- \*\* Insert P for Pre-Galvanized, G for Hot Dip Galvanized, SS6 for Stainless Steel 316
- Requires mitering of trays and drilling new splice plate holes on inside angle

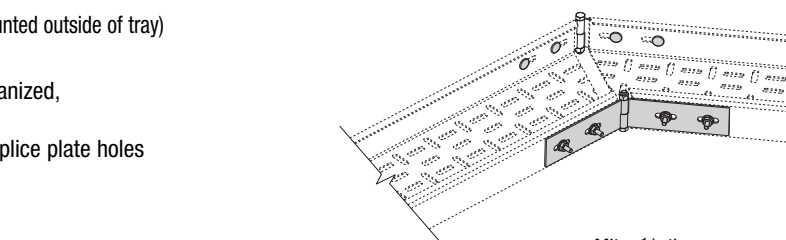

Miter 1/2 the required angle on each tray end

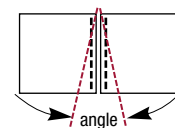

Example:  
40° bend requires  
20° miter each end

Part Number	Tray Height
PHA025**-NA	25
PHA050**-NA	50
PHA075**-NA	75
PHA100**-NA	100

All dimensions are in millimetres unless otherwise specified.

# Cable Tray - Splice Plates & Cover Clamps - Northern Asia

## Right/Left Reducer Splice Plates (Mounted outside of tray)

(Sold as a Set With Hardware)

- \*\* Insert P for Pre-Galvanized, G for Hot Dip Galvanized, SS6 for Stainless Steel 316
- \_\_ Width: Insert width difference between the two trays

Part Number	Tray Height
PLR025** -NA	25
PLR050** -NA	50
PLR075** -NA	75
PLR100** -NA	100

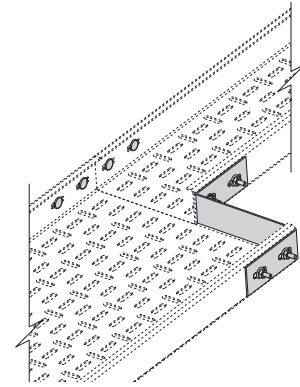
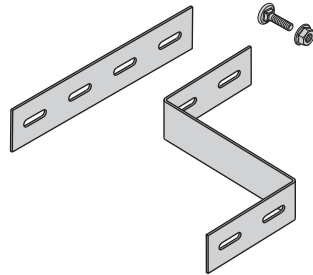

## Straight Reducer Splice Plates (Mounted outside of tray)

(Sold as a Set With Hardware)

- \*\* Insert P for Pre-Galvanized, G for Hot Dip Galvanized, SS6 for Stainless Steel 316
- \_\_ Width: Insert one half the width difference between the two trays

Part Number	Tray Height
PSR025** -NA	25
PSR050** -NA	50
PSR075** -NA	75
PSR100** -NA	100

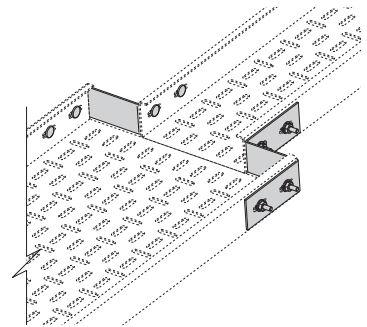
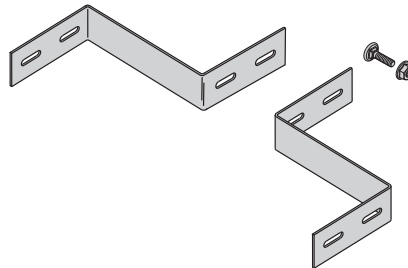

## Wrap-Around Cover Clamps

(Sold Individually With Hardware)

- \*\* Insert P for Pre-Galvanized, G for Hot Dip Galvanized, SS6 for Stainless Steel 316
- \_\_ Insert Tray Width  
 50 = 50mm, 100 = 100mm, 150 = 150mm, 200 = 200mm,  
 300 = 300mm, 400 = 400mm, 500 = 500mm, 600 = 600mm,  
 900 = 900mm

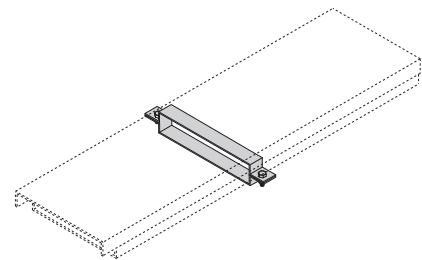
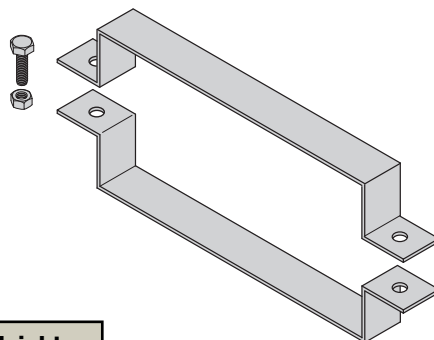

Part Number	Tray Height
PWCC025** __ -NA	25 *
PWCC050** __ -NA	50
PWCC075** __ -NA	75
PWCC100** __ -NA	100

\* Is not available in 900mm wide tray

# Cable Tray - Hold Downs & Hardware - Northern Asia

## Hold Downs - For (R) & (C) Flanges

(Sold in Pairs Without Hardware)

- \*\* Insert P for Pre-Galvanized, G for Hot Dip Galvanized, SS6 for Stainless Steel 316

Part Number	Tray Height
PHD025**-NA	25
PHD050**-NA	50
PHD075**-NA	75
PHD100**-NA	100

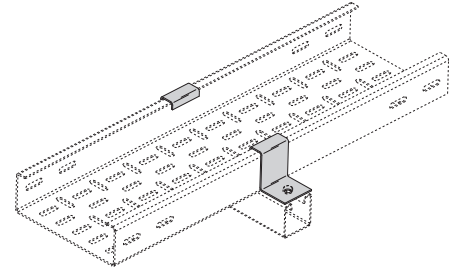
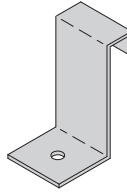

## AAHDW

### All Accessories Hardware

- Sold in bags of 50 sets
- Packaged in bulk bags with accessories that list hardware included

Each Set Includes:

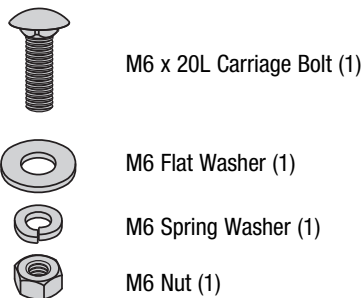

## BSPHDW

### Bottom Splice Plate Hardware

- Sold in bags of 50 sets
- Packaged in bulk bags with accessories that list hardware included

Each Set Includes:

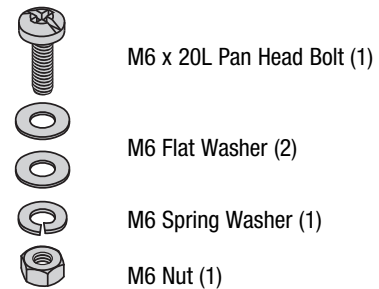

All dimensions are in millimetres unless otherwise specified.

# Cable Tray - Fittings - Northern Asia

Cable Tray Fittings are designed to support cables as they transition directions.

Note: Perforated slot dimensions and patterns may vary depending on tray size and type.  
All fitting bottom are shown as solid bottoms. Perforated bottoms are available.

**HB**  
Horizontal Bend  
(C) Formed Shown

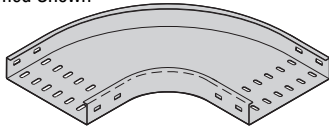

**HT**  
Horizontal Tee  
(R) Mitered Shown

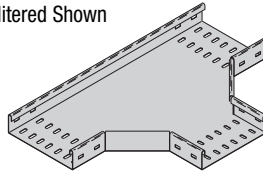

**HX**  
Horizontal Cross  
(C) Formed Shown

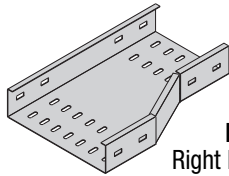
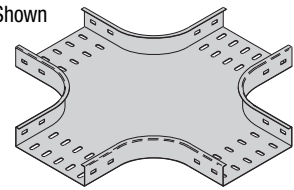

**LR**  
Right Reducer  
(C) Mitered Only

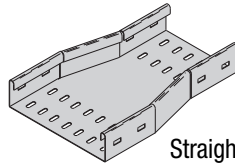

**SR**  
Straight Reducer  
(R) Mitered Only

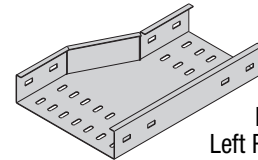

**RR**  
Left Reducer  
(C) Mitered Only

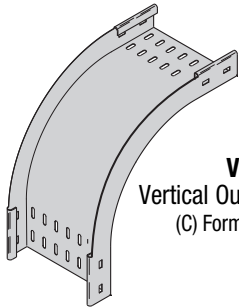

**VO**  
Vertical Outside Bend  
(C) Formed Only

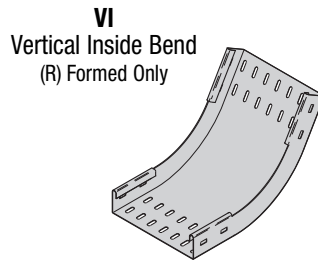

**VI**  
Vertical Inside Bend  
(R) Formed Only

### Splice Plate Holes

Fittings engineered with 100mm tangents for splicing integrity.

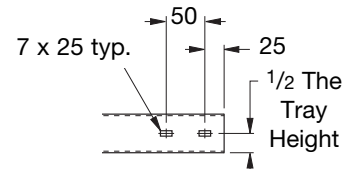

Perf & Solid Bottom Tray Northern Asia

## Fittings Part Numbering

Prefix

Example: **P F 050 V R SS6 10 HB - 200 - 60 R600 - NA** (Northern Asia)

Tray Type	Radius Detail	Height	Bottom Type	Return Flange Type	Material	Thickness	Type	Width	Angle †	Radius
<b>P</b> = (Perforated & Solid Cable Tray)	<b>F</b> = Formed <b>M</b> = Mitered	<b>025</b> = 25mm <b>050</b> = 50mm <b>075</b> = 75mm <b>100</b> = 100mm	<b>S</b> = Solid <b>V</b> = Perforated	<b>R</b> = 180° ††† <b>C</b> = 90°	<b>P</b> = Pre-Galv <b>G</b> = HDGAF <b>SS6</b> = Stainless Type 316	<b>10</b> * = 1.0mm <b>15</b> = 1.5mm <b>20</b> = 2.0mm	<b>HB</b> <b>HT</b> † <b>HX</b> † <b>VO</b> *** <b>VI</b> *** <b>RR</b> † <b>LR</b> † <b>SR</b> †	<b>050</b> = 50mm <b>100</b> = 100mm <b>150</b> = 150mm <b>200</b> = 200mm <b>300</b> = 300mm <b>400</b> = 400mm <b>500</b> = 500mm <b>600</b> = 600mm <b>900</b> = 900mm †††	<b>30</b> <b>45</b> <b>60</b> <b>90</b>	<b>R300</b> = 300mm <b>R600</b> = 600mm <b>R900</b> = 900mm

\* 1.0mm thickness is only available in widths up to and including 300 (300mm).

† No angle designation required on these fittings. See fitting page when creating part numbers.

\*\*\* Not available in mitered style

††† Not available on 025 tray heights

Δ Only available on 025 and 050 tray heights

All dimensions are in millimeters unless otherwise specified.

# Cable Tray - Fittings - Northern Asia

Note:

Perforated slot dimensions and patterns may vary depending on tray size and type.  
(R) 180° return flange not available on 025 tray heights.

## Horizontal Bends 90° (HB)

Splice plates not supplied with fittings.  
Order standard splice plates separately from page 59.  
One (1) pair required to connect to system.

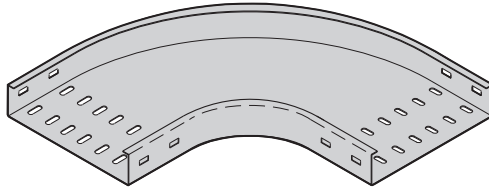

90° Horizontal Bend  
Formed (C) Rail Shown

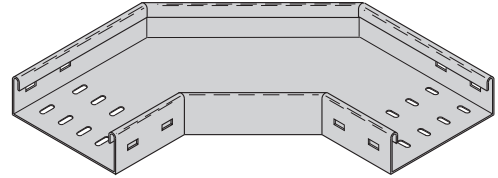

90° Horizontal Bend  
Mitered (R) Rail Shown

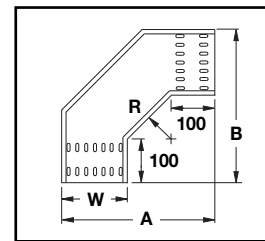
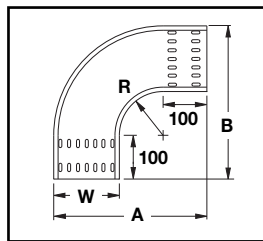

Bend Radius R mm	Tray Width W mm	90° Horizontal Bend Dimensions					
		Formed Radius Fittings			Mitered Radius Fittings		
		Catalog No.	A mm	B mm	Catalog No.	A mm	B mm
300	50	PF(Prefix)HB-050-90R300-NA	450	450	PM(Prefix)HB-050-90R300-NA	450	450
	100	PF(Prefix)HB-100-90R300-NA	500	500	PM(Prefix)HB-100-90R300-NA	500	500
	150	PF(Prefix)HB-150-90R300-NA	550	550	PM(Prefix)HB-150-90R300-NA	550	550
	200	PF(Prefix)HB-200-90R300-NA	600	600	PM(Prefix)HB-200-90R300-NA	600	600
	300	PF(Prefix)HB-300-90R300-NA	700	700	PM(Prefix)HB-300-90R300-NA	700	700
	400	PF(Prefix)HB-400-90R300-NA	800	800	PM(Prefix)HB-400-90R300-NA	800	800
	500	PF(Prefix)HB-500-90R300-NA	900	900	PM(Prefix)HB-500-90R300-NA	900	900
	600	PF(Prefix)HB-600-90R300-NA	1000	1000	PM(Prefix)HB-600-90R300-NA	1000	1000
600	900	PF(Prefix)HB-900-90R300-NA	1300	1300	PM(Prefix)HB-900-90R300-NA	1300	1300
	50	PF(Prefix)HB-050-90R600-NA	750	750	PM(Prefix)HB-050-90R600-NA	750	750
	100	PF(Prefix)HB-100-90R600-NA	800	800	PM(Prefix)HB-100-90R600-NA	800	800
	150	PF(Prefix)HB-150-90R600-NA	850	850	PM(Prefix)HB-150-90R600-NA	850	850
	200	PF(Prefix)HB-200-90R600-NA	900	900	PM(Prefix)HB-200-90R600-NA	900	900
	300	PF(Prefix)HB-300-90R600-NA	1000	1000	PM(Prefix)HB-300-90R600-NA	1000	1000
	400	PF(Prefix)HB-400-90R600-NA	1100	1100	PM(Prefix)HB-400-90R600-NA	1100	1100
	500	PF(Prefix)HB-500-90R600-NA	1200	1200	PM(Prefix)HB-500-90R600-NA	1200	1200
900	600	PF(Prefix)HB-600-90R600-NA	1300	1300	PM(Prefix)HB-600-90R600-NA	1300	1300
	900	PF(Prefix)HB-900-90R600-NA	1600	1600	PM(Prefix)HB-900-90R600-NA	1600	1600
	50	PF(Prefix)HB-050-90R900-NA	1050	1050	PM(Prefix)HB-050-90R900-NA	1050	1050
	100	PF(Prefix)HB-100-90R900-NA	1100	1100	PM(Prefix)HB-100-90R900-NA	1100	1100
	150	PF(Prefix)HB-150-90R900-NA	1150	1150	PM(Prefix)HB-150-90R900-NA	1150	1150
	200	PF(Prefix)HB-200-90R900-NA	1200	1200	PM(Prefix)HB-200-90R900-NA	1200	1200
	300	PF(Prefix)HB-300-90R900-NA	1300	1300	PM(Prefix)HB-300-90R900-NA	1300	1300
	400	PF(Prefix)HB-400-90R900-NA	1400	1400	PM(Prefix)HB-400-90R900-NA	1400	1400
900	500	PF(Prefix)HB-500-90R900-NA	1500	1500	PM(Prefix)HB-500-90R900-NA	1500	1500
	600	PF(Prefix)HB-600-90R900-NA	1600	1600	PM(Prefix)HB-600-90R900-NA	1600	1600
	600	PF(Prefix)HB-600-90R900-NA	1600	1600	PM(Prefix)HB-600-90R900-NA	1600	1600
	900	PF(Prefix)HB-900-90R900-NA	1900	1900	PM(Prefix)HB-900-90R900-NA	1900	1900

(Prefix) See page 63 for catalog number prefix and splice plate hole information.

Width dimensions are to inside wall. Manufacturing tolerances apply to all dimensions.

All dimensions are in millimeters unless otherwise specified.

# Cable Tray - Fittings - Northern Asia

## Horizontal Bends 60° (HB)

Splice plates not supplied with fittings.  
Order standard splice plates separately from page 59.  
One (1) pair required to connect to system.

Note:

Perforated slot dimensions and patterns may vary depending on tray size and type.  
(R) 180° return flange not available on 025 tray heights.

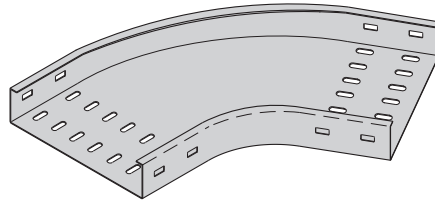

60° Horizontal Bend Formed (C) Shown

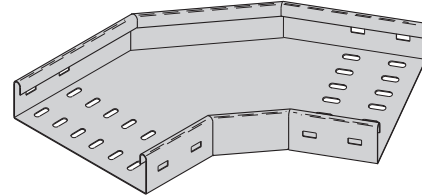

60° Horizontal Bend Mitered (R) Shown

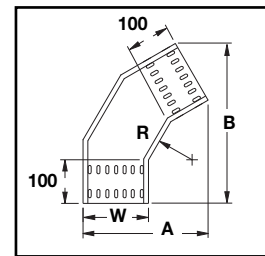
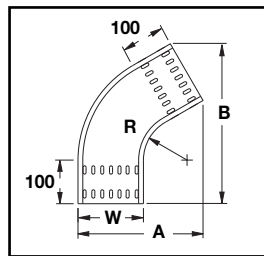

Bend Radius R mm	Tray Width W mm	60° Horizontal Bend Dimensions					
		Formed Radius Fittings			Mitered Radius Fittings		
		Catalog No.	A mm	B mm	Catalog No.	A mm	B mm
300	50	PF(Prefix)HB-050-60R300-NA	287	453	PM(Prefix)HB-050-60R300-NA	287	453
	100	PF(Prefix)HB-100-60R300-NA	337	496	PM(Prefix)HB-100-60R300-NA	337	496
	150	PF(Prefix)HB-150-60R300-NA	387	540	PM(Prefix)HB-150-60R300-NA	387	540
	200	PF(Prefix)HB-200-60R300-NA	437	583	PM(Prefix)HB-200-60R300-NA	437	583
	300	PF(Prefix)HB-300-60R300-NA	537	670	PM(Prefix)HB-300-60R300-NA	537	670
	400	PF(Prefix)HB-400-60R300-NA	637	756	PM(Prefix)HB-400-60R300-NA	637	756
	500	PF(Prefix)HB-500-60R300-NA	737	843	PM(Prefix)HB-500-60R300-NA	737	843
	600	PF(Prefix)HB-600-60R300-NA	837	929	PM(Prefix)HB-600-60R300-NA	837	929
	900	PF(Prefix)HB-900-60R300-NA	1137	1189	PM(Prefix)HB-900-60R300-NA	1137	1189
600	50	PF(Prefix)HB-050-60R600-NA	437	713	PM(Prefix)HB-050-60R600-NA	437	713
	100	PF(Prefix)HB-100-60R600-NA	487	756	PM(Prefix)HB-100-60R600-NA	487	756
	150	PF(Prefix)HB-150-60R600-NA	537	800	PM(Prefix)HB-150-60R600-NA	537	800
	200	PF(Prefix)HB-200-60R600-NA	587	843	PM(Prefix)HB-200-60R600-NA	587	843
	300	PF(Prefix)HB-300-60R600-NA	687	929	PM(Prefix)HB-300-60R600-NA	687	929
	400	PF(Prefix)HB-400-60R600-NA	787	1016	PM(Prefix)HB-400-60R600-NA	787	1016
	500	PF(Prefix)HB-500-60R600-NA	887	1103	PM(Prefix)HB-500-60R600-NA	887	1103
	600	PF(Prefix)HB-600-60R600-NA	987	1189	PM(Prefix)HB-600-60R600-NA	987	1189
	900	PF(Prefix)HB-900-60R600-NA	1287	1449	PM(Prefix)HB-900-60R600-NA	1287	1449
900	50	PF(Prefix)HB-050-60R900-NA	587	973	PM(Prefix)HB-050-60R900-NA	587	973
	100	PF(Prefix)HB-100-60R900-NA	637	1016	PM(Prefix)HB-100-60R900-NA	637	1016
	150	PF(Prefix)HB-150-60R900-NA	687	1053	PM(Prefix)HB-150-60R900-NA	687	1053
	200	PF(Prefix)HB-200-60R900-NA	737	1103	PM(Prefix)HB-200-60R900-NA	737	1103
	300	PF(Prefix)HB-300-60R900-NA	837	1189	PM(Prefix)HB-300-60R900-NA	837	1189
	400	PF(Prefix)HB-400-60R900-NA	967	1276	PM(Prefix)HB-400-60R900-NA	967	1276
	500	PF(Prefix)HB-500-60R900-NA	1037	1362	PM(Prefix)HB-500-60R900-NA	1037	1362
	600	PF(Prefix)HB-600-60R900-NA	1137	1449	PM(Prefix)HB-600-60R900-NA	1137	1449
	900	PF(Prefix)HB-900-60R900-NA	1437	1709	PM(Prefix)HB-900-60R900-NA	1437	1709

(Prefix) See page 63 for catalog number prefix and splice plate hole information.

Width dimensions are to inside wall. Manufacturing tolerances apply to all dimensions.

# Cable Tray - Fittings - Northern Asia

Note:

Perforated slot dimensions and patterns may vary depending on tray size and type.  
(R) 180° return flange not available on 025 tray heights.

## Horizontal Bends 45° (HB)

Splice plates not supplied with fittings.  
Order standard splice plates separately from page 59.  
One (1) pair required to connect to system.

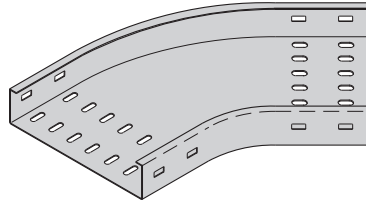

45° Horizontal Bend Formed (C) Shown

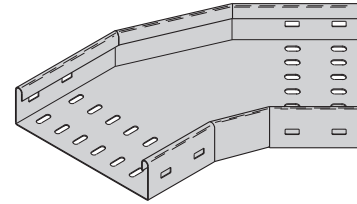
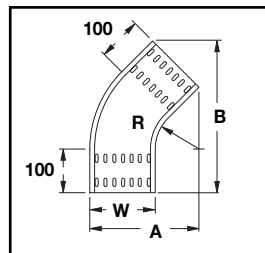

45° Horizontal Bend Mitered (R) Shown

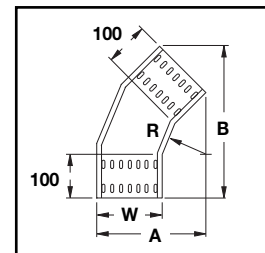

Bend Radius R mm	Tray Width W mm	45° Horizontal Bend Dimensions					
		Formed Radius Fittings			Mitered Radius Fittings		
		Catalog No.	A mm	B mm	Catalog No.	A mm	B mm
300	50	PF(Prefix)HB-050-45R300-NA	209	418	PM(Prefix)HB-050-45R300-NA	209	418
	100	PF(Prefix)HB-100-45R300-NA	259	454	PM(Prefix)HB-100-45R300-NA	259	454
	150	PF(Prefix)HB-150-45R300-NA	309	489	PM(Prefix)HB-150-45R300-NA	309	489
	200	PF(Prefix)HB-200-45R300-NA	359	524	PM(Prefix)HB-200-45R300-NA	459	595
	300	PF(Prefix)HB-300-45R300-NA	459	595	PM(Prefix)HB-300-45R300-NA	459	595
	400	PF(Prefix)HB-400-45R300-NA	559	666	PM(Prefix)HB-400-45R300-NA	559	666
	500	PF(Prefix)HB-500-45R300-NA	659	736	PM(Prefix)HB-500-45R300-NA	659	736
	600	PF(Prefix)HB-600-45R300-NA	759	807	PM(Prefix)HB-600-45R300-NA	759	807
600	900	PF(Prefix)HB-900-45R300-NA	1059	1019	PM(Prefix)HB-900-45R300-NA	1059	1019
	50	PF(Prefix)HB-050-45R600-NA	296	630	PM(Prefix)HB-050-45R600-NA	296	630
	100	PF(Prefix)HB-100-45R600-NA	346	666	PM(Prefix)HB-100-45R600-NA	346	666
	150	PF(Prefix)HB-150-45R600-NA	396	701	PM(Prefix)HB-150-45R600-NA	396	701
	200	PF(Prefix)HB-200-45R600-NA	446	736	PM(Prefix)HB-200-45R600-NA	446	736
	300	PF(Prefix)HB-300-45R600-NA	546	807	PM(Prefix)HB-300-45R600-NA	546	807
	400	PF(Prefix)HB-400-45R600-NA	646	878	PM(Prefix)HB-400-45R600-NA	646	878
	500	PF(Prefix)HB-500-45R600-NA	746	949	PM(Prefix)HB-500-45R600-NA	746	949
900	600	PF(Prefix)HB-600-45R600-NA	846	1019	PM(Prefix)HB-600-45R600-NA	846	1019
	900	PF(Prefix)HB-900-45R600-NA	1146	1231	PM(Prefix)HB-900-45R600-NA	1146	1231
	50	PF(Prefix)HB-050-45R900-NA	384	842	PM(Prefix)HB-050-45R900-NA	384	842
	100	PF(Prefix)HB-100-45R900-NA	434	878	PM(Prefix)HB-100-45R900-NA	434	878
	150	PF(Prefix)HB-150-45R900-NA	484	913	PM(Prefix)HB-150-45R900-NA	484	913
	200	PF(Prefix)HB-200-45R900-NA	534	949	PM(Prefix)HB-200-45R900-NA	534	949
	300	PF(Prefix)HB-300-45R900-NA	634	1019	PM(Prefix)HB-300-45R900-NA	634	1019
	400	PF(Prefix)HB-400-45R900-NA	734	1090	PM(Prefix)HB-400-45R900-NA	734	1090
	500	PF(Prefix)HB-500-45R900-NA	834	1161	PM(Prefix)HB-500-45R900-NA	834	1161
	600	PF(Prefix)HB-600-45R900-NA	934	1231	PM(Prefix)HB-600-45R900-NA	934	1231
	900	PF(Prefix)HB-900-45R900-NA	1234	1444	PM(Prefix)HB-900-45R900-NA	1234	1444

(Prefix) See page 63 for catalog number prefix and splice plate hole information.

Width dimensions are to inside wall. Manufacturing tolerances apply to all dimensions.

All dimensions are in millimeters unless otherwise specified.

# Cable Tray - Fittings - Northern Asia

## Horizontal Bends 30° (HB)

Splice plates not supplied with fittings.  
Order standard splice plates separately from page 59.  
One (1) pair required to connect to system.

Note:  
Perforated slot dimensions and patterns  
may vary depending on tray size and type.  
(R) 180° return flange not available on 025 tray heights.

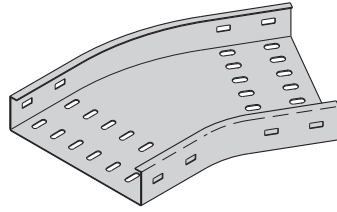

30° Horizontal Bend  
Formed (C) Shown

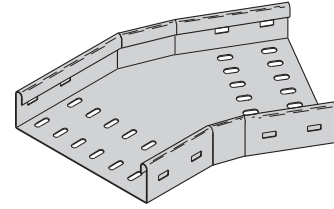

30° Horizontal Bend  
Mitered (R) Shown

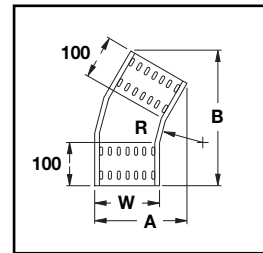
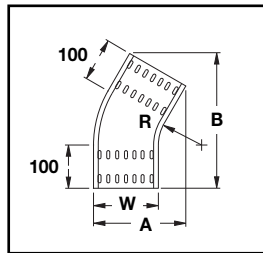

Bend Radius R mm	Tray Width W mm	30° Horizontal Bend Dimensions					
		Formed Radius Fittings			Mitered Radius Fittings		
		Catalog No.	A mm	B mm	Catalog No.	A mm	B mm
300	50	PF(Prefix)HB-050-30R300-NA	140	362	PM(Prefix)HB-050-30R300-NA	140	362
	100	PF(Prefix)HB-100-30R300-NA	190	387	PM(Prefix)HB-100-30R300-NA	190	387
	150	PF(Prefix)HB-150-30R300-NA	240	412	PM(Prefix)HB-150-30R300-NA	240	412
	200	PF(Prefix)HB-200-30R300-NA	290	637	PM(Prefix)HB-200-30R300-NA	290	637
	300	PF(Prefix)HB-300-30R300-NA	390	487	PM(Prefix)HB-300-30R300-NA	390	487
	400	PF(Prefix)HB-400-30R300-NA	490	537	PM(Prefix)HB-400-30R300-NA	490	537
	500	PF(Prefix)HB-500-30R300-NA	590	587	PM(Prefix)HB-500-30R300-NA	590	587
	600	PF(Prefix)HB-600-30R300-NA	690	637	PM(Prefix)HB-600-30R300-NA	690	637
	900	PF(Prefix)HB-900-30R300-NA	990	787	PM(Prefix)HB-900-30R300-NA	990	787
600	50	PF(Prefix)HB-050-30R600-NA	180	512	PM(Prefix)HB-050-30R600-NA	180	512
	100	PF(Prefix)HB-100-30R600-NA	230	537	PM(Prefix)HB-100-30R600-NA	230	537
	150	PF(Prefix)HB-150-30R600-NA	280	562	PM(Prefix)HB-150-30R600-NA	280	562
	200	PF(Prefix)HB-200-30R600-NA	330	587	PM(Prefix)HB-200-30R600-NA	330	587
	300	PF(Prefix)HB-300-30R600-NA	430	637	PM(Prefix)HB-300-30R600-NA	430	637
	400	PF(Prefix)HB-400-30R600-NA	530	687	PM(Prefix)HB-400-30R600-NA	530	687
	500	PF(Prefix)HB-500-30R600-NA	630	737	PM(Prefix)HB-500-30R600-NA	630	737
	600	PF(Prefix)HB-600-30R600-NA	730	787	PM(Prefix)HB-600-30R600-NA	730	787
	900	PF(Prefix)HB-900-30R600-NA	1030	937	PM(Prefix)HB-900-30R600-NA	1030	937
900	50	PF(Prefix)HB-050-30R900-NA	221	662	PM(Prefix)HB-050-30R900-NA	221	662
	100	PF(Prefix)HB-100-30R900-NA	271	687	PM(Prefix)HB-100-30R900-NA	271	687
	150	PF(Prefix)HB-150-30R900-NA	321	712	PM(Prefix)HB-150-30R900-NA	321	712
	200	PF(Prefix)HB-200-30R900-NA	371	737	PM(Prefix)HB-200-30R900-NA	371	737
	300	PF(Prefix)HB-300-30R900-NA	471	787	PM(Prefix)HB-300-30R900-NA	471	787
	400	PF(Prefix)HB-400-30R900-NA	571	837	PM(Prefix)HB-400-30R900-NA	571	837
	500	PF(Prefix)HB-500-30R900-NA	671	887	PM(Prefix)HB-500-30R900-NA	671	887
	600	PF(Prefix)HB-600-30R900-NA	771	937	PM(Prefix)HB-600-30R900-NA	771	937
	900	PF(Prefix)HB-900-30R900-NA	1071	1087	PM(Prefix)HB-900-30R900-NA	1071	1087

(Prefix) See page 63 for catalog number prefix and splice plate hole information.

Width dimensions are to inside wall. Manufacturing tolerances apply to all dimensions.

# Cable Tray - Fittings - Northern Asia

## Horizontal Tee (HT)

Note:

Perforated slot dimensions and patterns may vary depending on tray size and type.  
(R) 180° return flange not available on 025 tray heights.

Splice plates not supplied with fittings.  
Order standard splice plates separately from page 59.  
Two (2) pair required to connect to system.

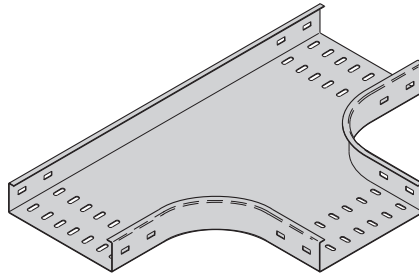

Horizontal Tee Fitted (C) Shown

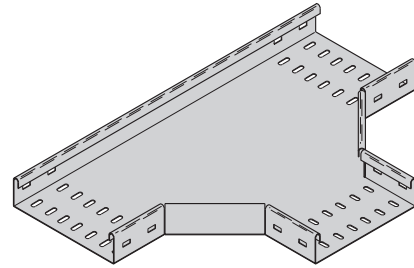
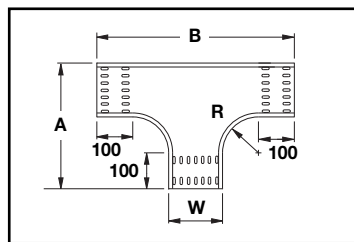

Horizontal Tee Fitted (R) Shown

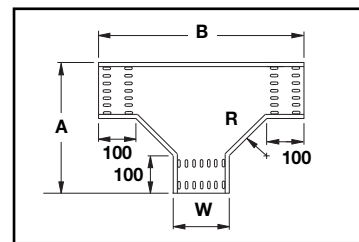

Bend Radius R mm	Tray Width W mm	Horizontal Tee Dimensions					
		Formed Radius Fittings			Mitered Radius Fittings		
		Catalog No.	A mm	B mm	Catalog No.	A mm	B mm
300	50	PF(Prefix)HT-050-R300-NA	450	850	PM(Prefix)HT-050-R300-NA	450	850
	100	PF(Prefix)HT-100-R300-NA	500	900	PM(Prefix)HT-100-R300-NA	500	900
	150	PF(Prefix)HT-150-R300-NA	550	950	PM(Prefix)HT-150-R300-NA	550	950
	200	PF(Prefix)HT-200-R300-NA	600	1000	PM(Prefix)HT-200-R300-NA	600	1000
	300	PF(Prefix)HT-300-R300-NA	700	1100	PM(Prefix)HT-300-R300-NA	700	1100
	400	PF(Prefix)HT-400-R300-NA	800	1200	PM(Prefix)HT-400-R300-NA	800	1200
	500	PF(Prefix)HT-500-R300-NA	900	1300	PM(Prefix)HT-500-R300-NA	900	1300
	600	PF(Prefix)HT-600-R300-NA	1000	1400	PM(Prefix)HT-600-R300-NA	1000	1400
	900	PF(Prefix)HT-900-R300-NA	1300	1700	PM(Prefix)HT-900-R300-NA	1300	1700
600	50	PF(Prefix)HT-050-R600-NA	750	1450	PM(Prefix)HT-050-R600-NA	750	1450
	100	PF(Prefix)HT-100-R600-NA	800	1500	PM(Prefix)HT-100-R600-NA	800	1500
	150	PF(Prefix)HT-150-R600-NA	850	1550	PM(Prefix)HT-150-R600-NA	850	1550
	200	PF(Prefix)HT-200-R600-NA	900	1600	PM(Prefix)HT-200-R600-NA	900	1600
	300	PF(Prefix)HT-300-R600-NA	1000	1700	PM(Prefix)HT-300-R600-NA	1000	1700
	400	PF(Prefix)HT-400-R600-NA	1100	1800	PM(Prefix)HT-400-R600-NA	1100	1800
	500	PF(Prefix)HT-500-R600-NA	1200	1900	PM(Prefix)HT-500-R600-NA	1200	1900
	600	PF(Prefix)HT-600-R600-NA	1300	2000	PM(Prefix)HT-600-R600-NA	1300	2000
	900	PF(Prefix)HT-900-R600-NA	1600	2300	PM(Prefix)HT-900-R600-NA	1600	2300
900	50	PF(Prefix)HT-050-R900-NA	1050	2050	PM(Prefix)HT-050-R900-NA	1050	2050
	100	PF(Prefix)HT-100-R900-NA	1100	2100	PM(Prefix)HT-100-R900-NA	1100	2100
	150	PF(Prefix)HT-150-R900-NA	1150	2150	PM(Prefix)HT-150-R900-NA	1150	2150
	200	PF(Prefix)HT-200-R900-NA	1200	2200	PM(Prefix)HT-200-R900-NA	1200	2200
	300	PF(Prefix)HT-300-R900-NA	1300	2300	PM(Prefix)HT-300-R900-NA	1300	2300
	400	PF(Prefix)HT-400-R900-NA	1400	2400	PM(Prefix)HT-400-R900-NA	1400	2400
	500	PF(Prefix)HT-500-R900-NA	1500	2500	PM(Prefix)HT-500-R900-NA	1500	2500
	600	PF(Prefix)HT-600-R900-NA	1600	2600	PM(Prefix)HT-600-R900-NA	1600	2600
	900	PF(Prefix)HT-900-R900-NA	1900	2900	PM(Prefix)HT-900-R900-NA	1900	2900

(Prefix) See page 63 for catalog number prefix and splice plate hole information.

Width dimensions are to inside wall. Manufacturing tolerances apply to all dimensions.

All dimensions are in millimeters unless otherwise specified.

# Cable Tray - Fittings - Northern Asia

## Horizontal Cross (HX)

Splice plates not supplied with fittings.  
 Order standard splice plates separately from page 59.  
 Three (3) pair required to connect to system.

Note:

Perforated slot dimensions and patterns may vary depending on tray size and type.  
 (R) 180° return flange not available on 025 tray heights.

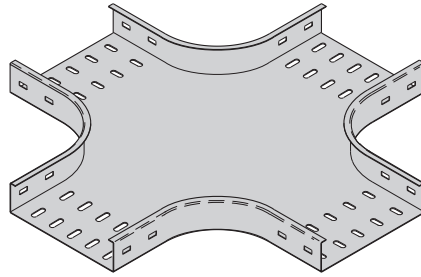

Horizontal Cross  
Formed (C) Shown

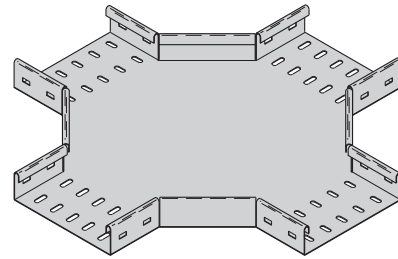
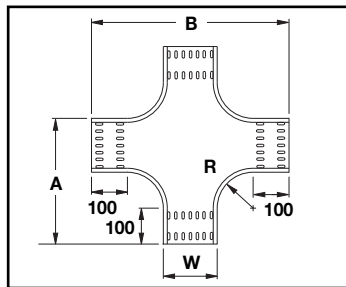

Horizontal Cross  
Mitered (R) Shown

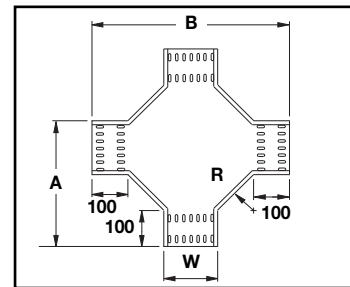

Bend Radius R mm	Tray Width W mm	Horizontal Cross Dimensions					
		Formed Radius Fittings			Mitered Radius Fittings		
		Catalog No.	A mm	B mm	Catalog No.	A mm	B mm
300	50	PF(Prefix)HX-050-R300-NA	450	850	PM(Prefix)HX-050-R300-NA	450	850
	100	PF(Prefix)HX-100-R300-NA	500	900	PM(Prefix)HX-100-R300-NA	500	900
	150	PF(Prefix)HX-150-R300-NA	550	950	PM(Prefix)HX-150-R300-NA	550	950
	200	PF(Prefix)HX-200-R300-NA	600	1000	PM(Prefix)HX-200-R300-NA	600	1000
	300	PF(Prefix)HX-300-R300-NA	700	1100	PM(Prefix)HX-300-R300-NA	700	1100
	400	PF(Prefix)HX-400-R300-NA	800	1200	PM(Prefix)HX-400-R300-NA	800	1200
	500	PF(Prefix)HX-500-R300-NA	900	1300	PM(Prefix)HX-500-R300-NA	900	1300
	600	PF(Prefix)HX-600-R300-NA	1000	1400	PM(Prefix)HX-600-R300-NA	1000	1400
	900	PF(Prefix)HX-900-R300-NA	1300	1700	PM(Prefix)HX-900-R300-NA	1300	1700
600	50	PF(Prefix)HX-050-R600-NA	750	1450	PM(Prefix)HX-050-R600-NA	750	1450
	100	PF(Prefix)HX-100-R600-NA	800	1500	PM(Prefix)HX-100-R600-NA	800	1500
	150	PF(Prefix)HX-150-R600-NA	850	1550	PM(Prefix)HX-150-R600-NA	850	1550
	200	PF(Prefix)HX-200-R600-NA	900	1600	PM(Prefix)HX-200-R600-NA	900	1600
	300	PF(Prefix)HX-300-R600-NA	1000	1700	PM(Prefix)HX-300-R600-NA	1000	1700
	400	PF(Prefix)HX-400-R600-NA	1100	1800	PM(Prefix)HX-400-R600-NA	1100	1800
	500	PF(Prefix)HX-500-R600-NA	1200	1900	PM(Prefix)HX-500-R600-NA	1200	1900
	600	PF(Prefix)HX-600-R600-NA	1300	2000	PM(Prefix)HX-600-R600-NA	1300	2000
	900	PF(Prefix)HX-900-R600-NA	1600	2300	PM(Prefix)HX-900-R600-NA	1600	2300
900	50	PF(Prefix)HX-050-R900-NA	1050	2050	PM(Prefix)HX-050-R900-NA	1050	2050
	100	PF(Prefix)HX-100-R900-NA	1100	2100	PM(Prefix)HX-100-R900-NA	1100	2100
	150	PF(Prefix)HX-150-R900-NA	1150	2150	PM(Prefix)HX-150-R900-NA	1150	2150
	200	PF(Prefix)HX-200-R900-NA	1200	2200	PM(Prefix)HX-200-R900-NA	1200	2200
	300	PF(Prefix)HX-300-R900-NA	1300	2300	PM(Prefix)HX-300-R900-NA	1300	2300
	400	PF(Prefix)HX-400-R900-NA	1400	2400	PM(Prefix)HX-400-R900-NA	1400	2400
	500	PF(Prefix)HX-500-R900-NA	1500	2500	PM(Prefix)HX-500-R900-NA	1500	2500
	600	PF(Prefix)HX-600-R900-NA	1600	2600	PM(Prefix)HX-600-R900-NA	1600	2600
	900	PF(Prefix)HX-900-R900-NA	1900	2900	PM(Prefix)HX-900-R900-NA	1900	2900

(Prefix) See page 63 for catalog number prefix and splice plate hole information.

Width dimensions are to inside wall. Manufacturing tolerances apply to all dimensions.

# Cable Tray - Fittings - Northern Asia

## Reducer Part Numbering

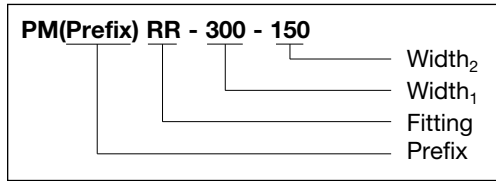

Note:

Perforated slot dimensions and patterns may vary depending on tray size and type.  
(R) 180° return flange not available on 025 tray heights.

## Left Reducer (LR) Straight Reducer (SR) Right Reducer (RR)

Splice plates not supplied with fittings.  
Order standard splice plates separately from page 59.  
One (1) pair required to connect to system.

Mitered \*\*

Tray Width		Left Hand Reducer		Straight Reducer		Right Hand Reducer	
W <sub>1</sub>	W <sub>2</sub>	Catalog No.	A	Catalog No.	A	Catalog No.	A
mm	mm		mm		mm		mm
100	50	PM(Prefix)-LR-100-050-NA	300	PM(Prefix)-SR-100-050-NA	300	PM(Prefix)-RR-100-050-NA	300
150	50	PM(Prefix)-LR-150-050-NA	300	PM(Prefix)-SR-150-050-NA	300	PM(Prefix)-RR-150-050-NA	300
	100	PM(Prefix)-LR-150-100-NA	300	PM(Prefix)-SR-150-100-NA	300	PM(Prefix)-RR-150-100-NA	300
200	50	PM(Prefix)-LR-200-050-NA	300	PM(Prefix)-SR-200-050-NA	300	PM(Prefix)-RR-200-050-NA	300
	100	PM(Prefix)-LR-200-100-NA	300	PM(Prefix)-SR-200-100-NA	300	PM(Prefix)-RR-200-100-NA	300
	150	PM(Prefix)-LR-200-150-NA	300	PM(Prefix)-SR-200-150-NA	300	PM(Prefix)-RR-200-150-NA	300
300	50	PM(Prefix)-LR-300-050-NA	300	PM(Prefix)-SR-300-050-NA	300	PM(Prefix)-RR-300-050-NA	300
	100	PM(Prefix)-LR-300-100-NA	300	PM(Prefix)-SR-300-100-NA	300	PM(Prefix)-RR-300-100-NA	300
	150	PM(Prefix)-LR-300-150-NA	300	PM(Prefix)-SR-300-150-NA	300	PM(Prefix)-RR-300-150-NA	300
	200	PM(Prefix)-LR-300-200-NA	300	PM(Prefix)-SR-300-200-NA	300	PM(Prefix)-RR-300-200-NA	300
400	50	PM(Prefix)-LR-400-050-NA	300	PM(Prefix)-SR-400-050-NA	300	PM(Prefix)-RR-400-050-NA	300
	100	PM(Prefix)-LR-400-100-NA	300	PM(Prefix)-SR-400-100-NA	300	PM(Prefix)-RR-400-100-NA	300
	150	PM(Prefix)-LR-400-150-NA	300	PM(Prefix)-SR-400-150-NA	300	PM(Prefix)-RR-400-150-NA	300
	200	PM(Prefix)-LR-400-200-NA	300	PM(Prefix)-SR-400-200-NA	300	PM(Prefix)-RR-400-200-NA	300
	300	PM(Prefix)-LR-400-300-NA	300	PM(Prefix)-SR-400-300-NA	300	PM(Prefix)-RR-400-300-NA	300
500	50	PM(Prefix)-LR-500-050-NA	300	PM(Prefix)-SR-500-050-NA	300	PM(Prefix)-RR-500-050-NA	300
	100	PM(Prefix)-LR-500-100-NA	300	PM(Prefix)-SR-500-100-NA	300	PM(Prefix)-RR-500-100-NA	300
	150	PM(Prefix)-LR-500-150-NA	300	PM(Prefix)-SR-500-150-NA	300	PM(Prefix)-RR-500-150-NA	300
	200	PM(Prefix)-LR-500-200-NA	300	PM(Prefix)-SR-500-200-NA	300	PM(Prefix)-RR-500-200-NA	300
	300	PM(Prefix)-LR-500-300-NA	300	PM(Prefix)-SR-500-300-NA	300	PM(Prefix)-RR-500-300-NA	300
	400	PM(Prefix)-LR-500-400-NA	300	PM(Prefix)-SR-500-400-NA	300	PM(Prefix)-RR-500-400-NA	300
600	50	PM(Prefix)-LR-600-050-NA	300	PM(Prefix)-SR-600-050-NA	300	PM(Prefix)-RR-600-050-NA	300
	100	PM(Prefix)-LR-600-100-NA	300	PM(Prefix)-SR-600-100-NA	300	PM(Prefix)-RR-600-100-NA	300
	150	PM(Prefix)-LR-600-150-NA	300	PM(Prefix)-SR-600-150-NA	300	PM(Prefix)-RR-600-150-NA	300
	200	PM(Prefix)-LR-600-200-NA	300	PM(Prefix)-SR-600-200-NA	300	PM(Prefix)-RR-600-200-NA	300
	300	PM(Prefix)-LR-600-300-NA	300	PM(Prefix)-SR-600-300-NA	300	PM(Prefix)-RR-600-300-NA	300
	400	PM(Prefix)-LR-600-400-NA	300	PM(Prefix)-SR-600-400-NA	300	PM(Prefix)-RR-600-400-NA	300
	500	PM(Prefix)-LR-600-500-NA	300	PM(Prefix)-SR-600-500-NA	300	PM(Prefix)-RR-600-500-NA	300
900	50	PM(Prefix)-LR-900-050-NA	300	PM(Prefix)-SR-900-050-NA	300	PM(Prefix)-RR-900-050-NA	300
	100	PM(Prefix)-LR-900-100-NA	300	PM(Prefix)-SR-900-100-NA	300	PM(Prefix)-RR-900-100-NA	300
	150	PM(Prefix)-LR-900-150-NA	300	PM(Prefix)-SR-900-150-NA	300	PM(Prefix)-RR-900-150-NA	300
	200	PM(Prefix)-LR-900-200-NA	300	PM(Prefix)-SR-900-200-NA	300	PM(Prefix)-RR-900-200-NA	300
	300	PM(Prefix)-LR-900-300-NA	300	PM(Prefix)-SR-900-300-NA	300	PM(Prefix)-RR-900-300-NA	300
	400	PM(Prefix)-LR-900-400-NA	300	PM(Prefix)-SR-900-400-NA	300	PM(Prefix)-RR-900-400-NA	300
	500	PM(Prefix)-LR-900-500-NA	300	PM(Prefix)-SR-900-500-NA	300	PM(Prefix)-RR-900-500-NA	300
	600	PM(Prefix)-LR-900-600-NA	300	PM(Prefix)-SR-900-600-NA	300	PM(Prefix)-RR-900-600-NA	300

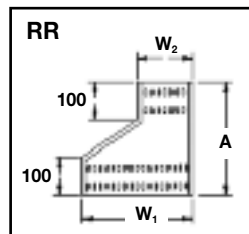
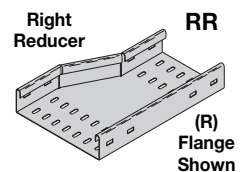
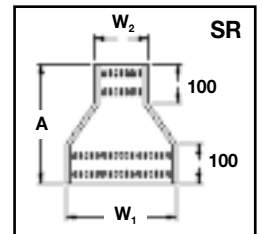
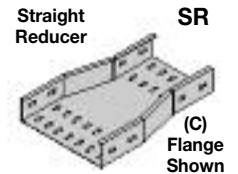
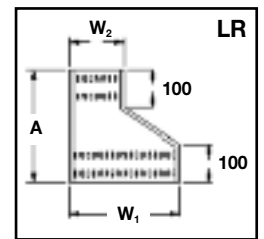
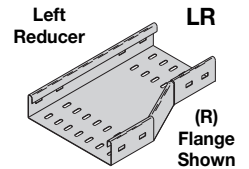

(Prefix) See page 63 for catalog number prefix and splice plate hole information.  
Width dimensions are to inside wall. Manufacturing tolerances apply to all dimensions.

\*\* Reducers are made only in the mitered style as shown

All dimensions are in millimeters unless otherwise specified.

# Cable Tray - Fittings - Northern Asia

## Vertical Bends 90° (VO, VI) Formed

Splice plates not supplied with fittings.  
Order standard splice plates separately from page 59.  
One (1) pair required to connect to system.

Note:

Perforated slot dimensions and patterns may vary depending on tray size and type.  
(R) 180° return flange not available on 025 tray heights.

90° Vertical Outside

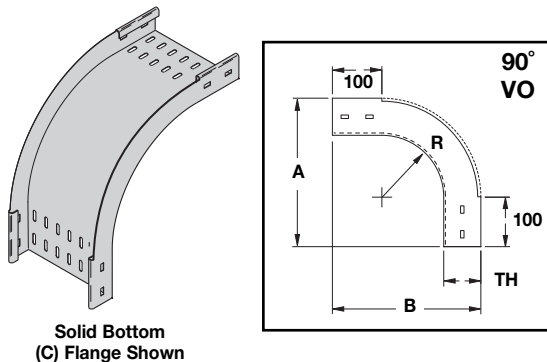

Solid Bottom  
(C) Flange Shown

90° Vertical Inside

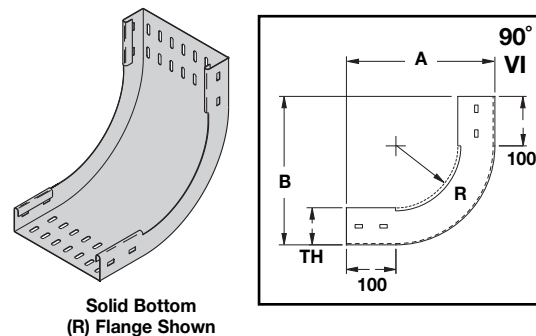

Solid Bottom  
(R) Flange Shown

### 90° Formed \*\*\*

Bend Radius R mm	Tray Width mm	(*) Insert "VO" for Vert. Outside Bend "VI" for Vert. Inside Bend Catalog No.	VO Tray Height (TH)								VI Tray Height (TH)							
			25mm		50mm		75mm		100mm		25mm		50mm		75mm		100mm	
			A mm	B mm	A mm	B mm	A mm	B mm	A mm	B mm	A mm	B mm	A mm	B mm	A mm	B mm	A mm	B mm
300	50	PF(Prefix)(*)-050-90R300-NA																
	100	PF(Prefix)(*)-100-90R300-NA																
	150	PF(Prefix)(*)-150-90R300-NA																
	200	PF(Prefix)(*)-200-90R300-NA																
	300	PF(Prefix)(*)-300-90R300-NA	425	425	450	450	475	475	500	500	425	425	450	450	475	475	500	500
	400	PF(Prefix)(*)-400-90R300-NA																
	500	PF(Prefix)(*)-500-90R300-NA																
	600	PF(Prefix)(*)-600-90R300-NA																
600	900	PF(Prefix)(*)-900-90R300-NA	N/A	N/A							N/A	N/A						
	50	PF(Prefix)(*)-050-90R600-NA																
	100	PF(Prefix)(*)-100-90R600-NA																
	150	PF(Prefix)(*)-150-90R600-NA																
	200	PF(Prefix)(*)-200-90R600-NA																
	300	PF(Prefix)(*)-300-90R600-NA	725	725	750	750	775	775	800	800	725	725	750	750	775	775	800	800
	400	PF(Prefix)(*)-400-90R600-NA																
	500	PF(Prefix)(*)-500-90R600-NA																
900	600	PF(Prefix)(*)-600-90R600-NA																
	900	PF(Prefix)(*)-900-90R600-NA	N/A	N/A							N/A	N/A						
	50	PF(Prefix)(*)-050-90R900-NA																
	100	PF(Prefix)(*)-100-90R900-NA																
	150	PF(Prefix)(*)-150-90R900-NA																
	200	PF(Prefix)(*)-200-90R900-NA																
	300	PF(Prefix)(*)-300-90R900-NA	1025	1025	1050	1050	1075	1075	1100	1100	1025	1025	1050	1050	1075	1075	1100	1100
	400	PF(Prefix)(*)-400-90R900-NA																
900	500	PF(Prefix)(*)-500-90R900-NA																
	600	PF(Prefix)(*)-600-90R900-NA																
	900	PF(Prefix)(*)-900-90R900-NA	N/A	N/A							N/A	N/A						

(Prefix) See page 63 for catalog number prefix and splice plate hole information.  
Width dimensions are to inside wall. Manufacturing tolerances apply to all dimensions.

\*\*\* Vertical inside and outside bends are made only in the formed style as shown

# Cable Tray - Fittings - Northern Asia

## Vertical Bends 60° (VO, VI) Formed

Note:

Perforated slot dimensions and patterns may vary depending on tray size and type.  
(R) 180° return flange not available on 025 tray heights.

Splice plates not supplied with fittings.  
Order standard splice plates separately from page 59.  
One (1) pair required to connect to system.

### 60° Vertical Outside

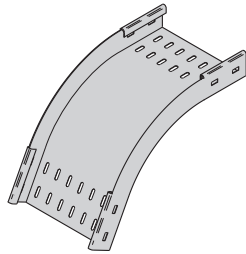

Solid Bottom  
(R) Flange Shown

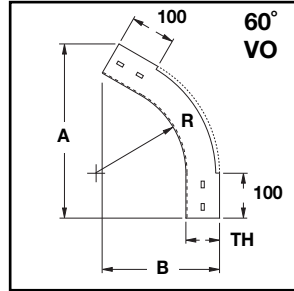

### 60° Vertical Inside

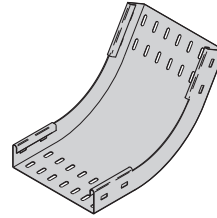

Solid Bottom  
(C) Flange Shown

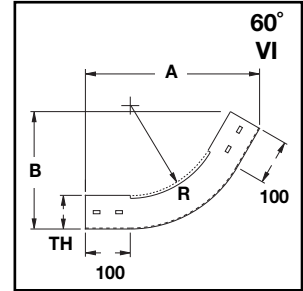

### 60° Formed \*\*\*

Bend Radius R mm	Tray Width mm	(*) Insert "VO" for Vert. Outside Bend "VI" for Vert. Inside Bend Catalog No.	VO Tray Height (TH)								VI Tray Height (TH)							
			25mm		50mm		75mm		100mm		25mm		50mm		75mm		100mm	
			A mm	B mm	A mm	B mm	A mm	B mm	A mm	B mm	A mm	B mm	A mm	B mm	A mm	B mm	A mm	B mm
300	50	PF(Prefix)(*)-050-60R300-NA																
	100	PF(Prefix)(*)-100-60R300-NA																
	150	PF(Prefix)(*)-150-60R300-NA																
	200	PF(Prefix)(*)-200-60R300-NA																
	300	PF(Prefix)(*)-300-60R300-NA	431	261	453	287	475	312	496	337	431	262	453	287	475	312	496	337
	400	PF(Prefix)(*)-400-60R300-NA																
	500	PF(Prefix)(*)-500-60R300-NA																
	600	PF(Prefix)(*)-600-60R300-NA																
	900	PF(Prefix)(*)-900-60R300-NA	N/A	N/A							N/A	N/A						
600	50	PF(Prefix)(*)-050-60R600-NA																
	100	PF(Prefix)(*)-100-60R600-NA																
	150	PF(Prefix)(*)-150-60R600-NA																
	200	PF(Prefix)(*)-200-60R600-NA																
	300	PF(Prefix)(*)-300-60R600-NA	691	411	713	437	735	462	756	487	691	412	713	437	735	462	756	487
	400	PF(Prefix)(*)-400-60R600-NA																
	500	PF(Prefix)(*)-500-60R600-NA																
	600	PF(Prefix)(*)-600-60R600-NA																
	900	PF(Prefix)(*)-900-60R600-NA	N/A	N/A							N/A	N/A						
900	50	PF(Prefix)(*)-050-60R900-NA																
	100	PF(Prefix)(*)-100-60R900-NA																
	150	PF(Prefix)(*)-150-60R900-NA																
	200	PF(Prefix)(*)-200-60R900-NA																
	300	PF(Prefix)(*)-300-60R900-NA	951	561	973	587	994	612	1016	637	951	562	973	587	994	612	1016	637
	400	PF(Prefix)(*)-400-60R900-NA																
	500	PF(Prefix)(*)-500-60R900-NA																
	600	PF(Prefix)(*)-600-60R900-NA																
	900	PF(Prefix)(*)-900-60R900-NA	N/A	N/A							N/A	N/A						

(Prefix) See page 63 for catalog number prefix and splice plate hole information.

Width dimensions are to inside wall. Manufacturing tolerances apply to all dimensions.

\*\*\* Vertical inside and outside bends are made only in the formed style as shown

All dimensions are in millimeters unless otherwise specified.

# Cable Tray - Fittings - Northern Asia

## Vertical Bends 45° (VO, VI) Formed

Splice plates not supplied with fittings.  
Order standard splice plates separately from page 59.  
One (1) pair required to connect to system.

Note:  
Perforated slot dimensions and patterns  
may vary depending on tray size and type.  
(R) 180° return flange not available on 025 tray heights.

45° Vertical Outside

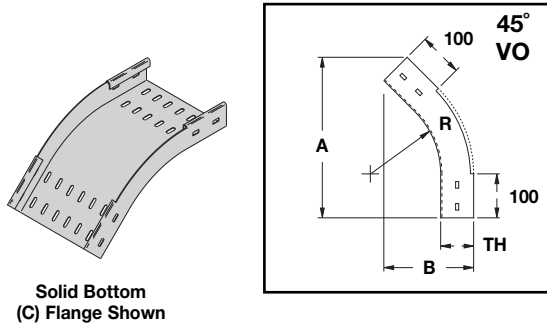

Solid Bottom  
(C) Flange Shown

45° Vertical Inside

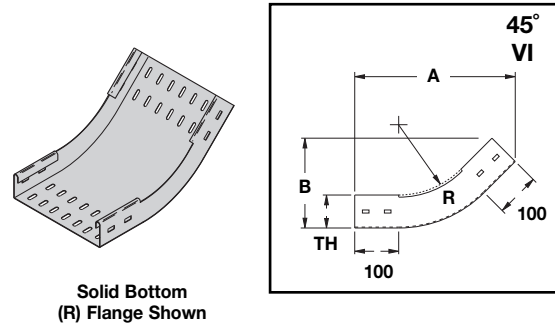

Solid Bottom  
(R) Flange Shown

### 45° Formed \*\*\*

Bend Radius R mm	Tray Width mm	(*) Insert "VO" for Vert. Outside Bend "VI" for Vert. Inside Bend Catalog No.	VO Tray Height (TH)								VI Tray Height (TH)							
			25mm		50mm		75mm		100mm		25mm		50mm		75mm		100mm	
			A mm	B mm	A mm	B mm	A mm	B mm	A mm	B mm	A mm	B mm	A mm	B mm	A mm	B mm	A mm	B mm
300	50	PF(Prefix)(*)-050-45R300-NA																
	100	PF(Prefix)(*)-100-45R300-NA																
	150	PF(Prefix)(*)-150-45R300-NA																
	200	PF(Prefix)(*)-200-45R300-NA																
	300	PF(Prefix)(*)-300-45R300-NA	401	184	418	209	436	234	454	259	401	184	418	209	436	234	454	259
	400	PF(Prefix)(*)-400-45R300-NA																
	500	PF(Prefix)(*)-500-45R300-NA																
	600	PF(Prefix)(*)-600-45R300-NA																
	900	PF(Prefix)(*)-900-45R300-NA	N/A	N/A							N/A	N/A						
600	50	PF(Prefix)(*)-050-45R600-NA																
	100	PF(Prefix)(*)-100-45R600-NA																
	150	PF(Prefix)(*)-150-45R600-NA																
	200	PF(Prefix)(*)-200-45R600-NA																
	300	PF(Prefix)(*)-300-45R600-NA	613	271	630	296	648	321	666	346	613	271	630	296	648	321	666	346
	400	PF(Prefix)(*)-400-45R600-NA																
	500	PF(Prefix)(*)-500-45R600-NA																
	600	PF(Prefix)(*)-600-45R600-NA																
	900	PF(Prefix)(*)-900-45R600-NA	N/A	N/A							N/A	N/A						
900	50	PF(Prefix)(*)-050-45R900-NA																
	100	PF(Prefix)(*)-100-45R900-NA																
	150	PF(Prefix)(*)-150-45R900-NA																
	200	PF(Prefix)(*)-200-45R900-NA																
	300	PF(Prefix)(*)-300-45R900-NA	825	359	842	384	860	409	878	434	825	359	842	384	860	409	878	434
	400	PF(Prefix)(*)-400-45R900-NA																
	500	PF(Prefix)(*)-500-45R900-NA																
	600	PF(Prefix)(*)-600-45R900-NA																
	900	PF(Prefix)(*)-900-45R900-NA	N/A	N/A							N/A	N/A						

(Prefix) See page 63 for catalog number prefix and splice plate hole information.

Width dimensions are to inside wall. Manufacturing tolerances apply to all dimensions.

\*\*\* Vertical inside and outside bends are made only in the formed style as shown

# Cable Tray - Fittings - Northern Asia

## Vertical Bends 30° (VO, VI) Formed

Note:

Perforated slot dimensions and patterns may vary depending on tray size and type.  
(R) 180° return flange not available on 025 tray heights.

Splice plates not supplied with fittings.  
Order standard splice plates separately from page 59.  
One (1) pair required to connect to system.

30° Vertical Outside

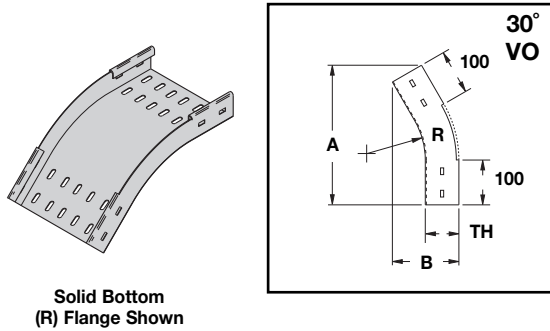

30° Vertical Inside

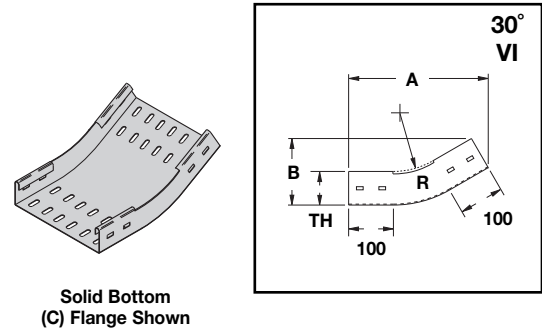

### 30° Formed \*\*\*

Bend Radius R mm	Tray Width mm	(*) Insert "VO" for Vert. Outside Bend "VI" for Vert. Inside Bend Catalog No.	VO Tray Height (TH)								VI Tray Height (TH)							
			25mm		50mm		75mm		100mm		25mm		50mm		75mm		100mm	
			A mm	B mm	A mm	B mm	A mm	B mm	A mm	B mm	A mm	B mm	A mm	B mm	A mm	B mm	A mm	B mm
300	50	PF(Prefix)(*)-050-30R300-NA																
	100	PF(Prefix)(*)-100-30R300-NA																
	150	PF(Prefix)(*)-150-30R300-NA																
	200	PF(Prefix)(*)-200-30R300-NA																
	300	PF(Prefix)(*)-300-30R300-NA	349	115	362	140	374	165	387	190	349	115	362	140	374	165	387	190
	400	PF(Prefix)(*)-400-30R300-NA																
	500	PF(Prefix)(*)-500-30R300-NA																
	600	PF(Prefix)(*)-600-30R300-NA																
900	PF(Prefix)(*)-900-30R300-NA	N/A	N/A							N/A	N/A							
600	50	PF(Prefix)(*)-050-30R600-NA																
	100	PF(Prefix)(*)-100-30R600-NA																
	150	PF(Prefix)(*)-150-30R600-NA																
	200	PF(Prefix)(*)-200-30R600-NA																
	300	PF(Prefix)(*)-300-30R600-NA	499	155	512	180	524	205	537	230	499	155	512	180	524	205	537	230
	400	PF(Prefix)(*)-400-30R600-NA																
	500	PF(Prefix)(*)-500-30R600-NA																
	600	PF(Prefix)(*)-600-30R600-NA																
900	PF(Prefix)(*)-900-30R600-NA	N/A	N/A							N/A	N/A							
900	50	PF(Prefix)(*)-050-30R900-NA																
	100	PF(Prefix)(*)-100-30R900-NA																
	150	PF(Prefix)(*)-150-30R900-NA																
	200	PF(Prefix)(*)-200-30R900-NA																
	300	PF(Prefix)(*)-300-30R900-NA	649	196	662	221	674	246	687	271	649	196	662	221	674	246	687	271
	400	PF(Prefix)(*)-400-30R900-NA																
	500	PF(Prefix)(*)-500-30R900-NA																
	600	PF(Prefix)(*)-600-30R900-NA																
900	PF(Prefix)(*)-900-30R900-NA	N/A	N/A							N/A	N/A							

(Prefix) See page 63 for catalog number prefix and splice plate hole information.

Width dimensions are to inside wall. Manufacturing tolerances apply to all dimensions.

\*\*\* Vertical inside and outside bends are made only in the formed style as shown

All dimensions are in millimeters unless otherwise specified.

## Straight Section Covers

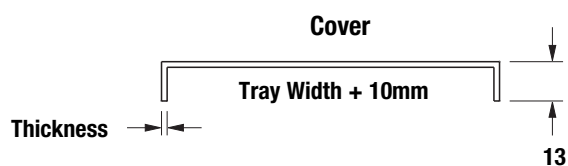
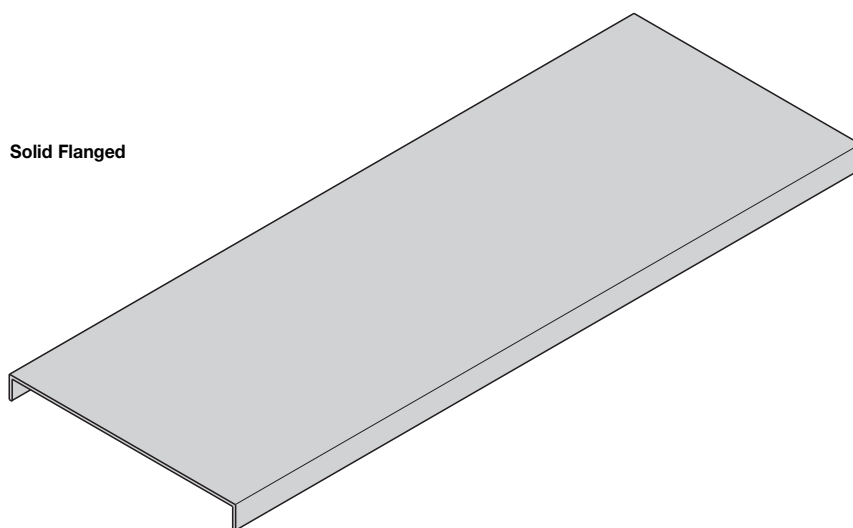

**A full range of covers is available for straight sections.**

**Solid flanged covers** should be used when maximum enclosure of the cable is desired and no accumulation of heat is expected.

**Flanged covers** have a 13mm flange.

Cover clamps are not included with the cover and must be ordered separately.

## Straight Section Covers

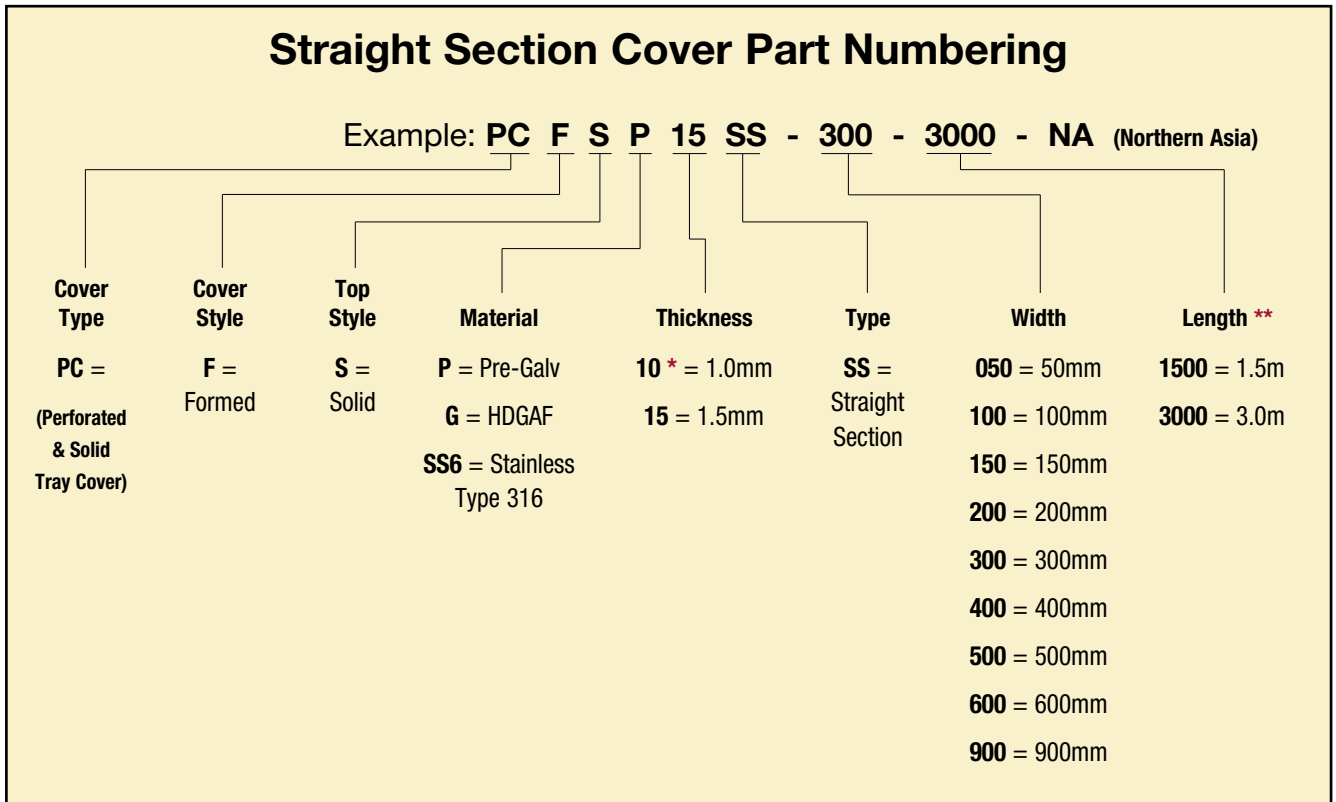

Perf & Solid Bottom Tray  
Northern Asia

\* 1.0mm thickness is only available in widths up to and including 300 (300mm).

\*\* All G (galvanized steel) covers only available in 1500 (1.5m) lengths.

All 900 (900mm) widths only available in 1500 (1.5m) lengths.

## Fitting Covers

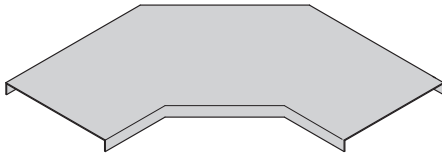

**HT**  
Horizontal Bend  
Mitered Shown

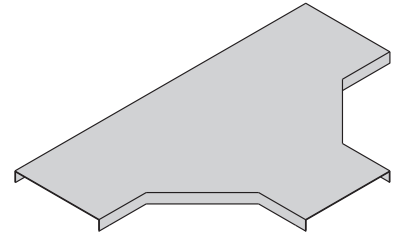

**HT**  
Horizontal Tee  
Mitered Shown

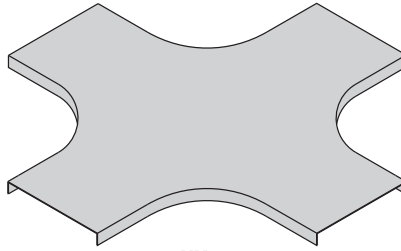

**HX**  
Horizontal Cross  
Formed Shown

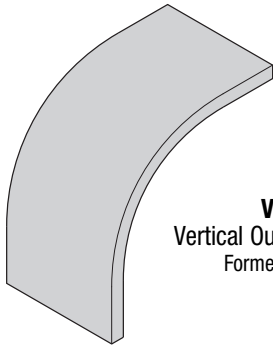

**VO**  
Vertical Outside Bend  
Formed Only

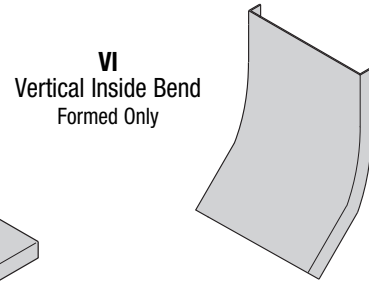

**VI**  
Vertical Inside Bend  
Formed Only

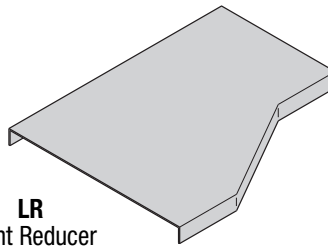

**LR**  
Right Reducer  
Mitered Only

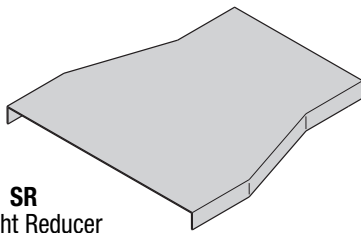

**SR**  
Straight Reducer  
Mitered Only

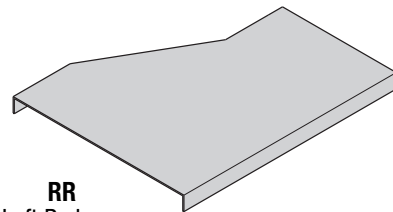

**RR**  
Left Reducer  
Mitered Only

**A full range of covers are available for fittings.**

**Solid flanged covers** should be used when maximum enclosure of the cable is desired and no accumulation of heat is expected.

**Flanged covers** have a 13mm flange. Cover clamps are not included with the cover and must be ordered separately.

## Fitting Covers

Fitting Cover Part Numbering									
Example: <b>PC F S P 15 HB - 500 - 60 R600 - 050 - NA</b> (Northern Asia)									
Cover Type	Cover Style	Top Style	Material	Thickness	Type	Width	Angle †	Radius	Tray Height †††
<b>PC =</b> (Perforated & Solid Tray Fitting Cover)	<b>F =</b> Formed	<b>S =</b> Solid	<b>P =</b> Pre-Galv <b>G =</b> HDGAF <b>SS6 *</b> = Stainless Type 316	<b>10 *</b> = 1.0mm <b>15</b> = 1.5mm	<b>HB</b> <b>HT †</b> <b>HX †</b> <b>VO ***</b> <b>VI ***</b> <b>RR †</b> <b>LR †</b> <b>SR †</b>	<b>050</b> = 50mm <b>100</b> = 100mm <b>150</b> = 150mm <b>200</b> = 200mm <b>300</b> = 300mm <b>400</b> = 400mm <b>500</b> = 500mm <b>600</b> = 600mm <b>900</b> = 900mm	<b>30</b> <b>45</b> <b>60</b> <b>90</b>	<b>R300</b> = 300mm <b>R600</b> = 600mm <b>R900</b> = 900mm	<b>025</b> = 25mm <b>050</b> = 50mm <b>075</b> = 75mm <b>100</b> = 100mm

Perf & Solid Bottom Tray  
Northern Asia

\* 1.0mm thickness is only available in widths up to and including 300 (300mm).

† No angle designation required on these fitting covers.

\*\*\* Not available as a mitered cover

††† Required on VO part numbers only.

All dimensions are in millimeters unless otherwise specified.

# Perforated & Solid Bottom Cable Tray - Southern Asia

Straight Sections See pages 81 - 84  
Straight Section Covers See pages 101 - 102

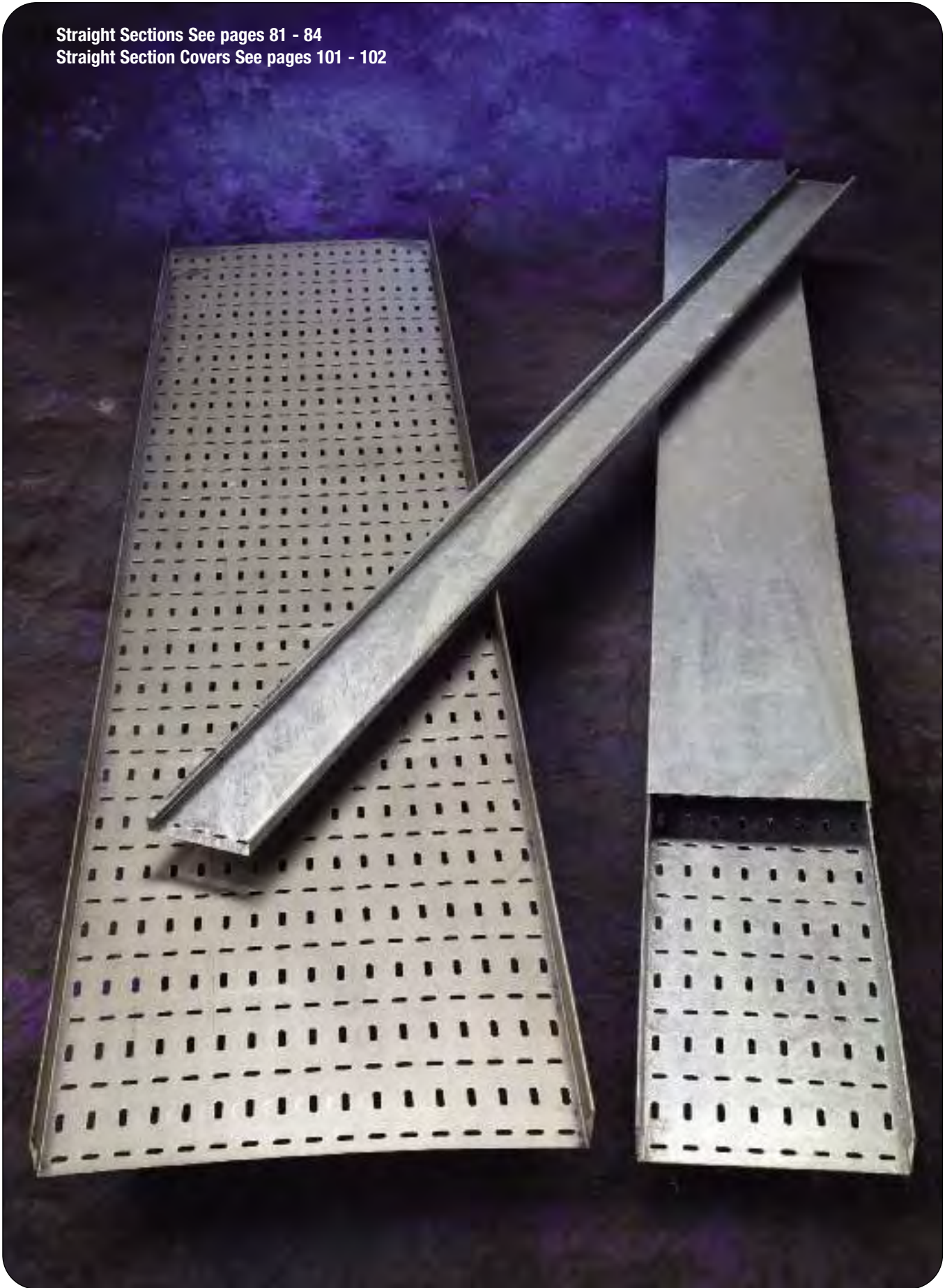

Perf & Solid Bottom Tray  
Southern Asia

# Perforated & Solid Bottom Cable Tray - Southern Asia

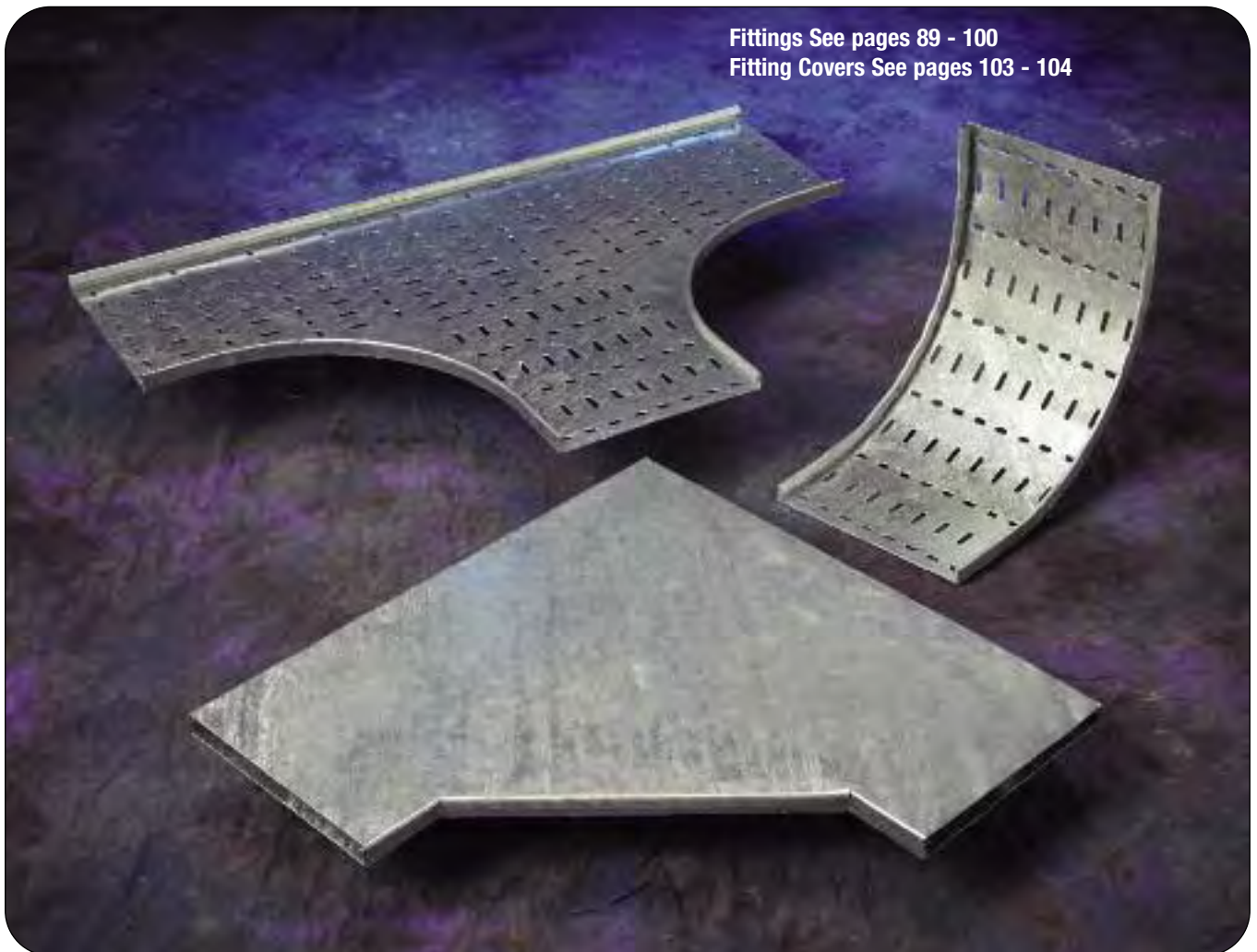
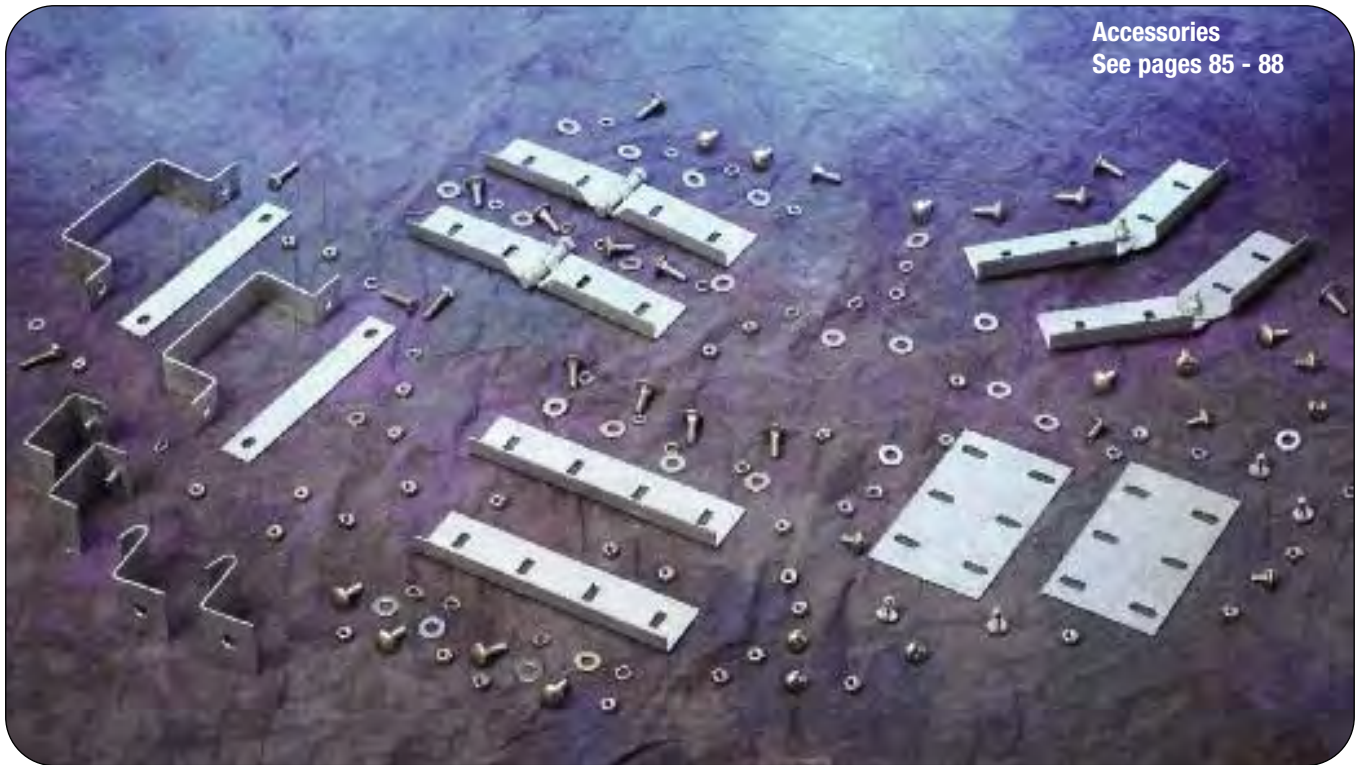

Perf & Solid Bottom Tray  
Southern Asia

All dimensions are in millimeters unless otherwise specified.

# Cable Tray - Straight Sections - Southern Asia

## Straight Section Part Numbering - 25mm Height

Example: **P 025 V C P 15 SS - 200 - 3000 - SA** (Southern Asia)

Tray Type	Height	Bottom Type	Return Flange Type	Material	Thickness	Type	Width	Length
<b>P =</b> (Perforated & Solid Cable Tray)	<b>025 =</b> 25mm	<b>S = Solid</b> <b>V = Perforated</b>	<b>C = 90°</b>	<b>P = Pre-Galv</b> <b>G = HDGAF</b> <b>SS6 = Stainless Type 316</b>	<b>10 * = 1.0mm</b> <b>15 = 1.5mm</b> <b>20 = 2.0mm</b>	<b>SS =</b> Straight Section	<b>050 = 50mm</b> <b>100 = 100mm</b> <b>150 = 150mm</b> <b>200 = 200mm</b> <b>300 = 300mm</b> <b>400 = 400mm</b> <b>500 = 500mm</b> <b>600 = 600mm</b>	<b>3000 =</b> 3000mm

\* 1.0mm thickness is only available in widths up to and including 300 (300mm).

Splice plates not supplied with straight sections. Order standard splice plates separately from page 85. One (1) pair required to connect to system.

### 90° Return Flange (C) with Solid Bottom (S)

### 90° Return Flange (C) with Perforated Bottom (V)

Notes:

Perforated slot dimensions and patterns may vary depending on tray size and type.

The 180° return flange is not available on 025 tray heights.

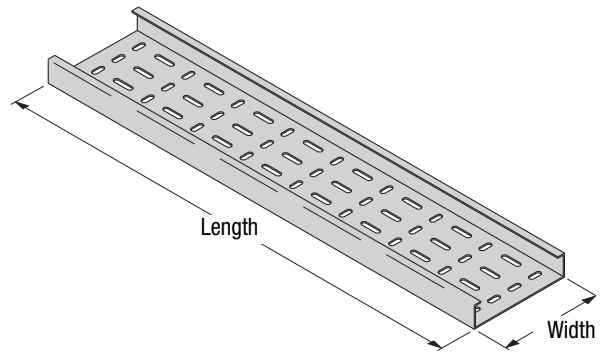
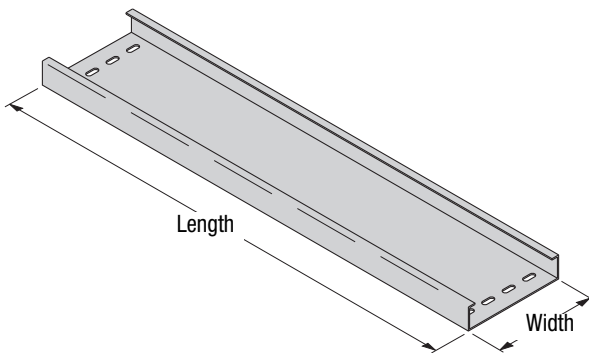

## Perforated & Solid Cable Tray Dimensional Drawing - Tray Height 25mm

### 90° Return Flange (C)

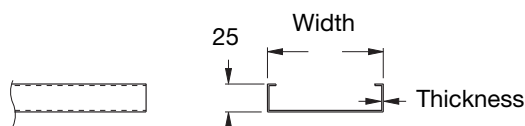

# Cable Tray - Straight Sections - Southern Asia

## Straight Section Part Numbering - 50mm Height

Example: **P 050 V C P 15 SS - 200 - 3000 - SA** (Southern Asia)

Tray Type	Height	Bottom Type	Return Flange Type	Material	Thickness	Type	Width	Length
<b>P =</b> (Perforated & Solid Cable Tray)	<b>050 =</b> 50mm	<b>S = Solid</b> <b>V = Perforated</b>	<b>R = 180°</b> <b>C = 90°</b>	<b>P = Pre-Galv</b> <b>G = HDGAF</b> <b>SS6 = Stainless Type 316</b>	<b>10 * = 1.0mm</b> <b>15 = 1.5mm</b> <b>20 = 2.0mm</b>	<b>SS =</b> Straight Section	<b>050 = 50mm</b> <b>100 = 100mm</b> <b>150 = 150mm</b> <b>200 = 200mm</b> <b>300 = 300mm</b> <b>400 = 400mm</b> <b>500 = 500mm</b> <b>600 = 600mm</b> <b>900 = 900mm</b>	<b>3000 =</b> 3000mm

\* 1.0mm thickness is only available in widths up to and including 300 (300mm).

Splice plates not supplied with straight sections. Order standard splice plates separately from page 85. One (1) pair required to connect to system.

### 180° Return Flange (R) with Solid Bottom (S)

### 90° Return Flange (C) with Perforated Bottom (V)

Note:

Perforated slot dimensions and patterns may vary depending on tray size and type.

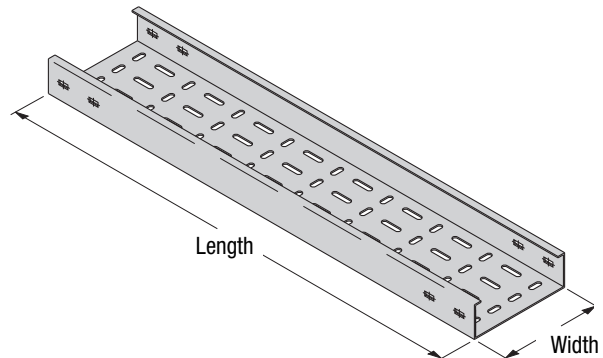
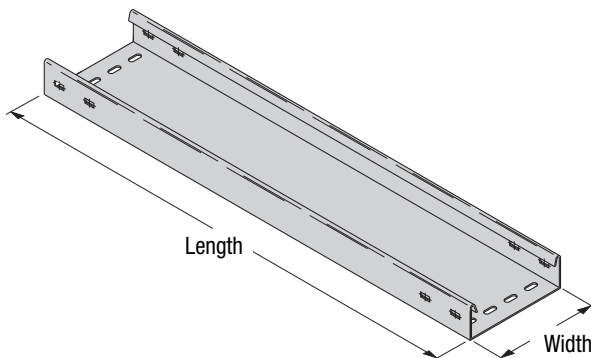

## Perforated & Solid Cable Tray Dimensional Drawing - Tray Height 50mm

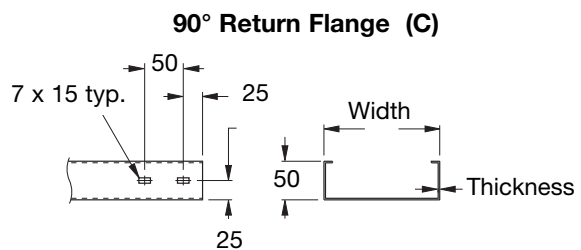
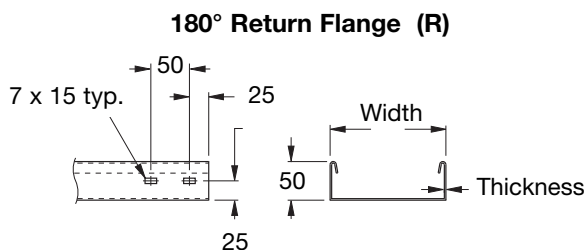

All dimensions are in millimeters unless otherwise specified.

# Cable Tray - Straight Sections - Southern Asia

## Straight Section Part Numbering - 75mm Height

Example: **P 075 V C P 15 SS - 200 - 3000 - SA** (Southern Asia)

Tray Type	Height	Bottom Type	Return Flange Type	Material	Thickness	Type	Width	Length
<b>P =</b> (Perforated & Solid Cable Tray)	<b>075 =</b> 75mm	<b>S = Solid</b> <b>V = Perforated</b>	<b>R = 180°</b> <b>C = 90°</b>	<b>P = Pre-Galv</b> <b>G = HDGAF</b> <b>SS6 = Stainless Type 316</b>	<b>10 * = 1.0mm</b> <b>15 = 1.5mm</b> <b>20 = 2.0mm</b>	<b>SS =</b> Straight Section	<b>100 = 100mm</b> <b>150 = 150mm</b> <b>200 = 200mm</b> <b>300 = 300mm</b> <b>400 = 400mm</b> <b>500 = 500mm</b> <b>600 = 600mm</b> <b>900 = 900mm</b>	<b>3000 =</b> 3000mm

\* 1.0mm thickness is only available in widths up to and including 300 (300mm).

Splice plates not supplied with straight sections. Order standard splice plates separately from page 85. One (1) pair required to connect to system.

### 180° Return Flange (R) with Solid Bottom (S)

### 90° Return Flange (C) with Perforated Bottom (V)

Note:

Perforated slot dimensions and patterns may vary depending on tray size and type.

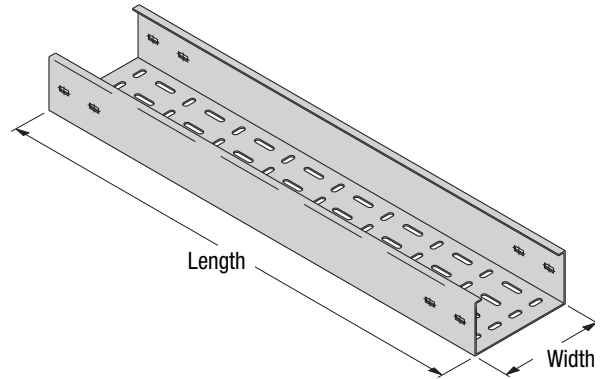
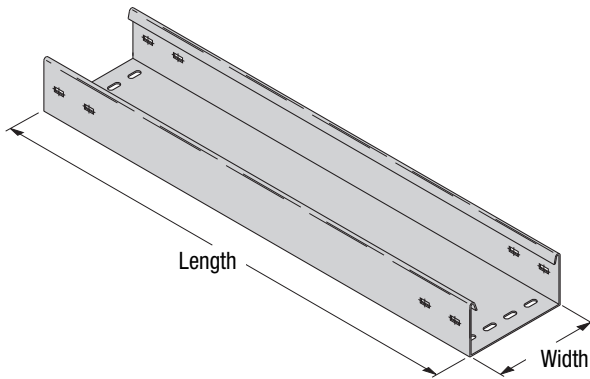

## Perforated & Solid Cable Tray Dimensional Drawing - Tray Height 75mm

### 180° Return Flange (R)

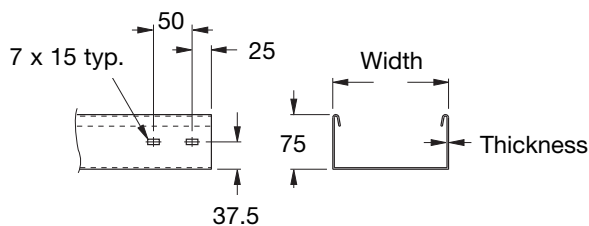

### 90° Return Flange (C)

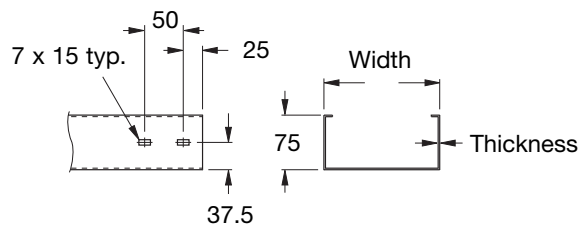

All dimensions are in millimeters unless otherwise specified.

# Cable Tray - Straight Sections - Southern Asia

## Straight Section Part Numbering - 100mm Height

Example: **P 100 V C P 15 SS - 200 - 3000 - SA** (Southern Asia)

Tray Type	Height	Bottom Type	Return Flange Type	Material	Thickness	Type	Width	Length
<b>P =</b> (Perforated & Solid Cable Tray)	<b>100 =</b> 100mm	<b>S = Solid</b> <b>V = Perforated</b>	<b>R = 180°</b> <b>C = 90°</b>	<b>P = Pre-Galv</b> <b>G = HDGAF</b> <b>SS6 = Stainless Type 316</b>	<b>10 * = 1.0mm</b> <b>15 = 1.5mm</b> <b>20 = 2.0mm</b>	<b>SS =</b> Straight Section	<b>100 = 100mm</b> <b>150 = 150mm</b> <b>200 = 200mm</b> <b>300 = 300mm</b> <b>400 = 400mm</b> <b>500 = 500mm</b> <b>600 = 600mm</b> <b>900 = 900mm</b>	<b>3000 =</b> 3000mm

\* 1.0mm thickness is only available in widths up to and including 300 (300mm).

Splice plates not supplied with straight sections. Order standard splice plates separately from page 85. One (1) pair required to connect to system.

### 180° Return Flange (R) with Solid Bottom (S)

### 90° Return Flange (C) with Perforated Bottom (V)

Note:

Perforated slot dimensions and patterns may vary depending on tray size and type.

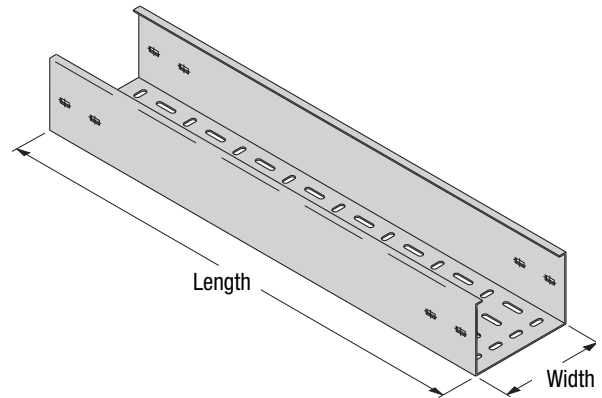
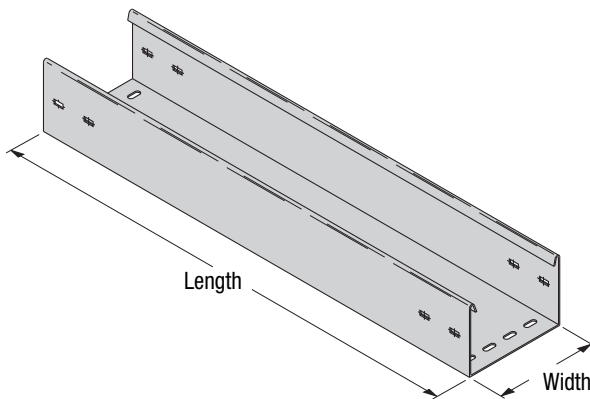

## Perforated & Solid Cable Tray Dimensional Drawing - Side Rail Height 100mm

### 180° Return Flange (R)

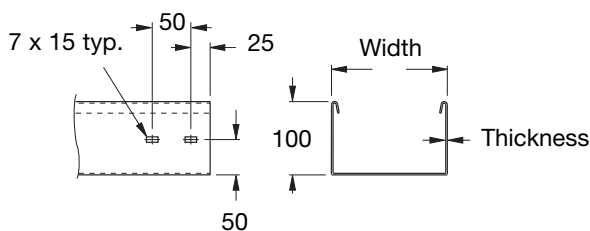

### 90° Return Flange (C)

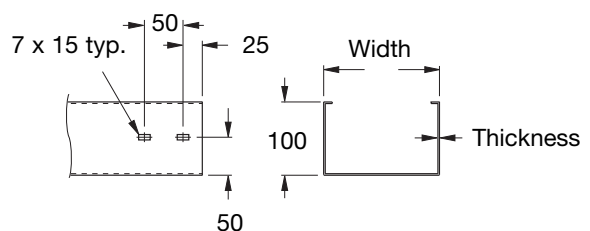

All dimensions are in millimeters unless otherwise specified.

# Cable Tray - Splice Plates - Southern Asia

## Bottom Splice Plates (Mounted on bottom of 025 height trays as splice plates and can also be used to stabilize tray connections on other heights)

(Sold Individually With Hardware)

- \*\* Insert P for Pre-Galvanized, G for Hot Dip Galvanized, SS6 for Stainless Steel 316

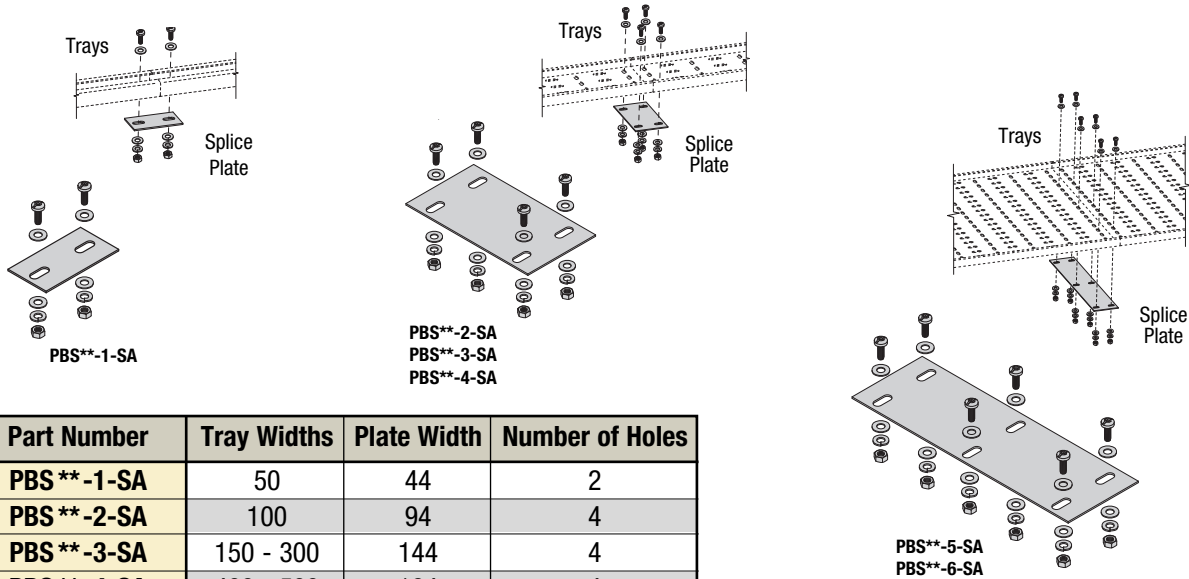

Part Number	Tray Widths	Plate Width	Number of Holes
PBS**-1-SA	50	44	2
PBS**-2-SA	100	94	4
PBS**-3-SA	150 - 300	144	4
PBS**-4-SA	400 - 500	194	4
PBS**-5-SA	600	394	6
PBS**-6-SA	900	594	6

## Side Splice Plates (Mounted inside of tray)

(Sold in Pairs With Hardware)

- \*\* Insert P for Pre-Galvanized, G for Hot Dip Galvanized, SS6 for Stainless Steel 316

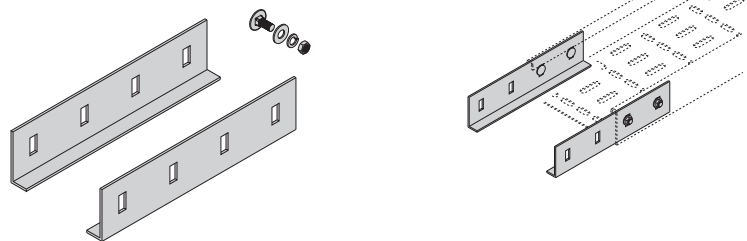

Part Number	Tray Height
PSP050**-SA	50
PSP075**-SA	75
PSP100**-SA	100

## Horizontal Adjustable Splice Plates (Mounted inside of tray)

(Sold in Pairs With Hardware)

- \*\* Insert P for Pre-Galvanized, G for Hot Dip Galvanized, SS6 for Stainless Steel 316
- Requires mitering of trays and drilling new splice plate holes on inside angle

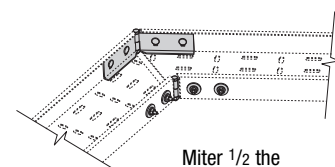
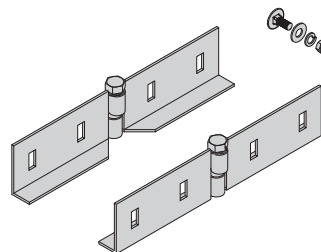

Miter 1/2 the required angle on each tray end

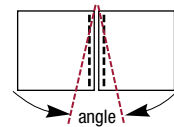

Example:  
40° bend requires  
20° miter each end

Part Number	Tray Height
PHA050**-SA	50
PHA075**-SA	75
PHA100**-SA	100

All dimensions are in millimeters unless otherwise specified.

## Expansion Splice Plates (Mounted inside of tray)

(Sold in Pairs With Hardware)

- \*\* Insert P for Pre-Galvanized, G for Hot Dip Galvanized, SS6 for Stainless Steel 316

Part Number	Tray Height
PEP050** -SA	50
PEP075** -SA	75
PEP100** -SA	100

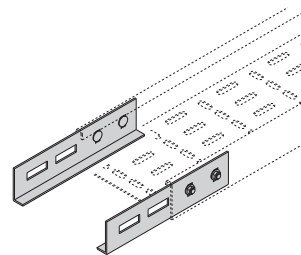
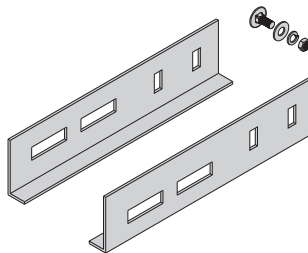

## Vertical Adjustable Splice Plates (Mounted inside of tray)

(Sold in Pairs With Hardware)

- \*\* Insert P for Pre-Galvanized, G for Hot Dip Galvanized, SS6 for Stainless Steel 316

Part Number	Tray Height
PVA050** -SA	50
PVA075** -SA	75
PVA100** -SA	100

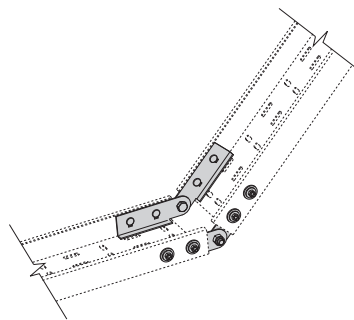
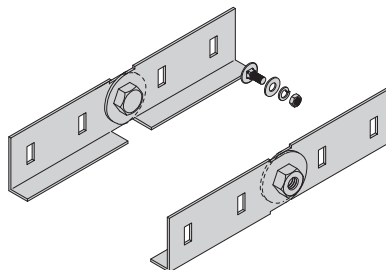

## Right/Left Reducer Splice Plates (Mounted inside of tray)

(Sold as a Set With Hardware)

- \*\* Insert P for Pre-Galvanized, G for Hot Dip Galvanized, SS6 for Stainless Steel 316
- \_\_ Width: Insert width difference between the two trays

Part Number	Tray Height
PLR050** __ -SA	50
PLR075** __ -SA	75
PLR100** __ -SA	100

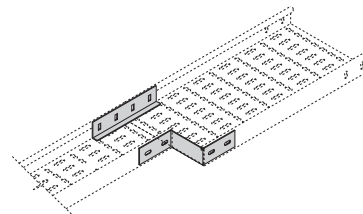
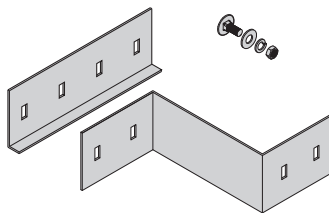

## Straight Reducer Splice Plates (Mounted inside of tray)

(Sold as a Set With Hardware)

- \*\* Insert P for Pre-Galvanized, G for Hot Dip Galvanized, SS6 for Stainless Steel 316
- \_\_ Width: Insert one half the width difference between the two trays

Part Number	Tray Height
PSR050** __ -SA	50
PSR075** __ -SA	75
PSR100** __ -SA	100

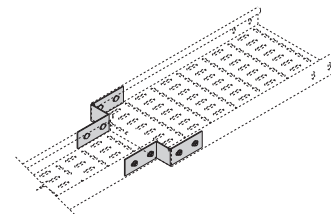
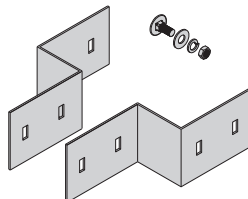

## Wrap-Around Cover Clamps

(Sold Individually With Hardware)

- \*\* Insert P for Pre-Galvanized, G for Hot Dip Galvanized, SS6 for Stainless Steel 316
- \_\_\_ Insert Tray Width of  
 050 = 50mm, 100 = 100mm, 150 = 150mm,  
 200 = 200mm, 300 = 300mm, 400 = 400mm,  
 500 = 500mm, 600 = 600mm, 900 = 900mm

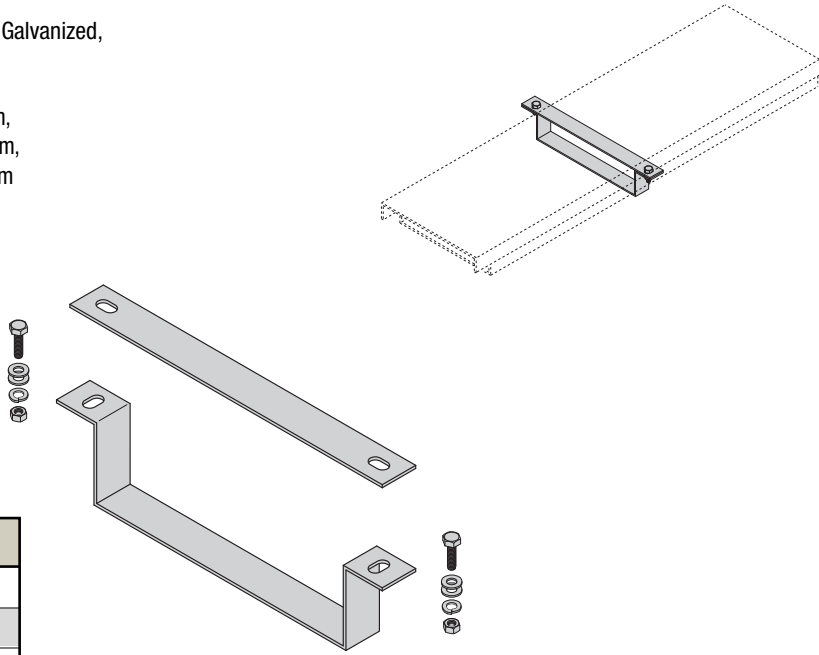

Part Number	Tray Height
PWCC025**__-SA	25 *
PWCC050**__-SA	50
PWCC075**__-SA	75
PWCC100**__-SA	100

\* Is not available in 900mm wide tray

## C-Shape Cover Clamps

(Sold in Pairs With Hardware)

- \*\* Insert G for Hot Dip Galvanized, SS6 for Stainless Steel 316

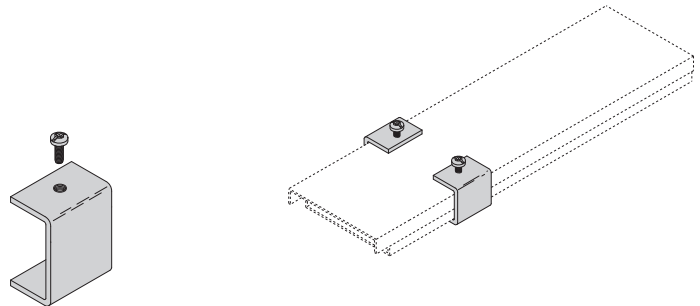

Part Number	Tray Height
PCCC025**__-SA	25
PCCC050**__-SA	50
PCCC075**__-SA	75
PCCC100**__-SA	100







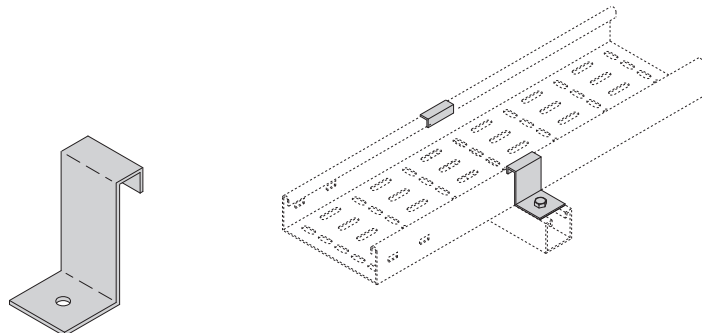





## Hold Downs - For (R) & (C) Flanges

(Sold in Pairs Without Hardware)

- \*\* Insert P for Pre-Galvanized, G for Hot Dip Galvanized, SS6 for Stainless Steel 316
- Not recommended for use with covers

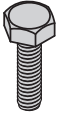

Part Number	Tray Height
PHD025**__-SA	25
PHD050**__-SA	50
PHD075**__-SA	75
PHD100**__-SA	100

<p><b>AAHDW</b> <b>All Accessories Hardware</b></p> <ul style="list-style-type: none"> <li>• Sold in bags of 50 sets</li> <li>• Packaged in bulk bags with accessories that list hardware included</li> </ul> <p>Each Set Includes:</p> <div style="display: flex; flex-direction: column; align-items: flex-start;"> <div style="display: flex; align-items: center; margin-bottom: 10px;">  <div style="margin-left: 10px;">M6 x 20L Carriage Bolt (1)</div> </div> <div style="display: flex; align-items: center; margin-bottom: 10px;">  <div style="margin-left: 10px;">M6 Flat Washer (1)</div> </div> <div style="display: flex; align-items: center; margin-bottom: 10px;">  <div style="margin-left: 10px;">M6 Spring Washer (1)</div> </div> <div style="display: flex; align-items: center;">  <div style="margin-left: 10px;">M6 Nut (1)</div> </div> </div>	<p><b>BSPHDW</b> <b>Bottom Splice Plate Hardware</b></p> <ul style="list-style-type: none"> <li>• Sold in bags of 50 sets</li> <li>• Packaged in bulk bags with accessories that list hardware included</li> </ul> <p>Each Set Includes:</p> <div style="display: flex; flex-direction: column; align-items: flex-start;"> <div style="display: flex; align-items: center; margin-bottom: 10px;">  <div style="margin-left: 10px;">M6 x 20L Pan Head Bolt (1)</div> </div> <div style="display: flex; align-items: center; margin-bottom: 10px;">  <div style="margin-left: 10px;">M6 Flat Washer (2)</div> </div> <div style="display: flex; align-items: center; margin-bottom: 10px;">  <div style="margin-left: 10px;">M6 Spring Washer (1)</div> </div> <div style="display: flex; align-items: center;">  <div style="margin-left: 10px;">M6 Nut (1)</div> </div> </div>
<p><b>WACCHDW</b> <b>Wrap Around Cover Clamp Hardware</b></p> <ul style="list-style-type: none"> <li>• Sold in bags of 50 sets</li> <li>• Packaged in bulk bags with accessories that list hardware included</li> </ul> <p>Each Set Includes:</p> <div style="display: flex; flex-direction: column; align-items: flex-start;"> <div style="display: flex; align-items: center; margin-bottom: 10px;">  <div style="margin-left: 10px;">M6 x 25L Hex Bolt (1)</div> </div> <div style="display: flex; align-items: center; margin-bottom: 10px;">  <div style="margin-left: 10px;">M6 Flat Washer (2)</div> </div> <div style="display: flex; align-items: center; margin-bottom: 10px;">  <div style="margin-left: 10px;">M6 Spring Washer (1)</div> </div> <div style="display: flex; align-items: center;">  <div style="margin-left: 10px;">M6 Nut (1)</div> </div> </div>	<p><b>CSCCHDW</b> <b>C Shape Cover Clamp Hardware</b></p> <ul style="list-style-type: none"> <li>• Sold in bags of 50 sets</li> <li>• Packaged in bulk bags with accessories that list hardware included</li> </ul> <p>Each Set Includes:</p> <div style="display: flex; flex-direction: column; align-items: flex-start;"> <div style="display: flex; align-items: center; margin-bottom: 10px;">  <div style="margin-left: 10px;">M6 x 12L Pan Head (1)</div> </div> </div>

# Cable Tray - Fittings - Southern Asia

Cable Tray Fittings are designed to support cables as they transition directions.

Note: Perforated slot dimensions and patterns may vary depending on tray size and type.  
All fitting bottom are shown as solid bottoms. Perforated bottoms are available.

**HB**  
Horizontal Bend  
(C) Formed Shown

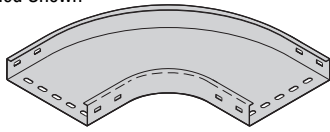

**HT**  
Horizontal Tee  
(R) Mitered Shown

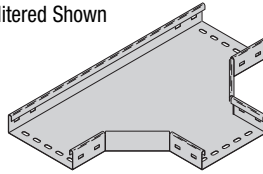

**HX**  
Horizontal Cross  
(C) Formed Shown

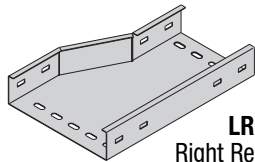
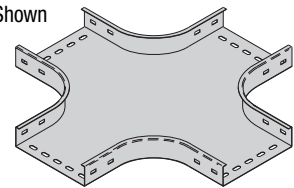

**LR**  
Right Reducer  
(C) Mitered Only

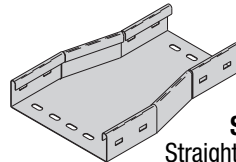

**SR**  
Straight Reducer  
(R) Mitered Only

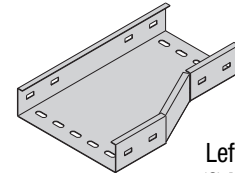

**RR**  
Left Reducer  
(C) Mitered Only

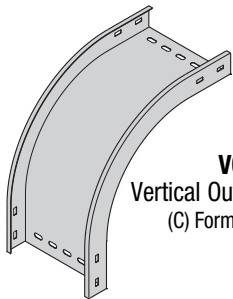

**VO**  
Vertical Outside Bend  
(C) Formed Only

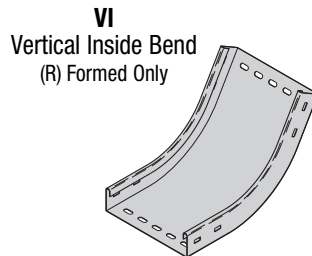

**VI**  
Vertical Inside Bend  
(R) Formed Only

### Splice Plate Holes

Fittings engineered with 100mm tangents for splicing integrity.

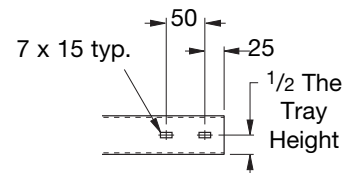

Note:

Fittings with 25mm tray heights do not have splice plate holes in the rails.

Perf & Solid Bottom Tray Southern Asia

## Fittings Part Numbering

Prefix

Example: **P F 050 V R SS6 10 HB - 200 - 60 R600 - SA** (Southern Asia)

Tray Type	Radius Detail	Height	Bottom Type	Return Flange Type	Material	Thickness	Type	Width	Angle †	Radius
<b>P</b> = (Perforated & Solid Cable Tray)	<b>F</b> = Formed <b>M</b> = Mitered	<b>025</b> = 25mm <b>050</b> = 50mm <b>075</b> = 75mm <b>100</b> = 100mm	<b>S</b> = Solid <b>V</b> = Perforated	<b>R</b> = 180° ††† <b>C</b> = 90°	<b>P</b> = Pre-Galv <b>G</b> = HDGAF <b>SS6</b> = Stainless Type 316	<b>10</b> * = 1.0mm <b>15</b> = 1.5mm <b>20</b> = 2.0mm	<b>HB</b> <b>HT</b> † <b>HX</b> † <b>VO</b> *** <b>VI</b> *** <b>RR</b> † <b>LR</b> † <b>SR</b> †	<b>050</b> = 50mm <b>100</b> = 100mm <b>150</b> = 150mm <b>200</b> = 200mm <b>300</b> = 300mm <b>400</b> = 400mm <b>500</b> = 500mm <b>600</b> = 600mm <b>900</b> = 900mm †††	<b>30</b> <b>45</b> <b>60</b> <b>90</b>	<b>R300</b> = 300mm <b>R600</b> = 600mm <b>R900</b> = 900mm

\* 1.0mm thickness is only available in widths up to and including 300 (300mm).

† No angle designation required on these fittings. See fitting page when creating part numbers.

\*\*\* Not available in mitered style

††† Not available on 025 tray heights

Δ Only available on 025 and 050 tray heights

All dimensions are in millimeters unless otherwise specified.

# Cable Tray - Fittings - Southern Asia

Note:

Perforated slot dimensions and patterns may vary depending on tray size and type.  
(R) 180° return flange not available on 025 tray heights.

## Horizontal Bends 90° (HB)

Splice plates not supplied with fittings.  
Order standard splice plates separately from page 85.  
One (1) pair required to connect to system.

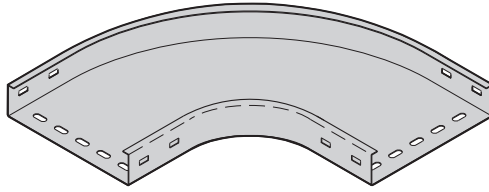

90° Horizontal Bend  
Formed (C) Rail Shown

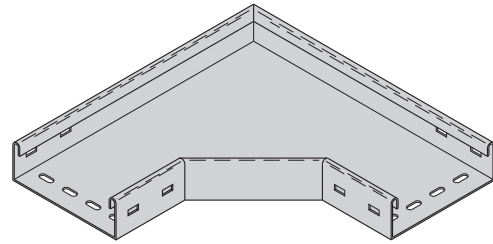

90° Horizontal Bend  
Mitered (R) Rail Shown

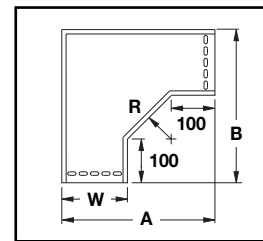
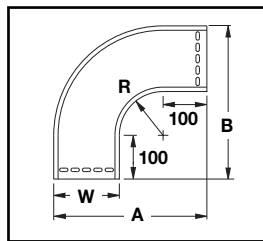

Bend Radius R mm	Tray Width W mm	90° Horizontal Bend Dimensions					
		Formed Radius Fittings			Mitered Radius Fittings		
		Catalog No.	A mm	B mm	Catalog No.	A mm	B mm
300	50	PF(Prefix)HB-050-90R300-SA	450	450	PM(Prefix)HB-050-90R300-SA	450	450
	100	PF(Prefix)HB-100-90R300-SA	500	500	PM(Prefix)HB-100-90R300-SA	500	500
	150	PF(Prefix)HB-150-90R300-SA	550	550	PM(Prefix)HB-150-90R300-SA	550	550
	200	PF(Prefix)HB-200-90R300-SA	600	600	PM(Prefix)HB-200-90R300-SA	600	600
	300	PF(Prefix)HB-300-90R300-SA	700	700	PM(Prefix)HB-300-90R300-SA	700	700
	400	PF(Prefix)HB-400-90R300-SA	800	800	PM(Prefix)HB-400-90R300-SA	800	800
	500	PF(Prefix)HB-500-90R300-SA	900	900	PM(Prefix)HB-500-90R300-SA	900	900
	600	PF(Prefix)HB-600-90R300-SA	1000	1000	PM(Prefix)HB-600-90R300-SA	1000	1000
600	900	PF(Prefix)HB-900-90R300-SA	1300	1300	PM(Prefix)HB-900-90R300-SA	1300	1300
	50	PF(Prefix)HB-050-90R600-SA	750	750	PM(Prefix)HB-050-90R600-SA	750	750
	100	PF(Prefix)HB-100-90R600-SA	800	800	PM(Prefix)HB-100-90R600-SA	800	800
	150	PF(Prefix)HB-150-90R600-SA	850	850	PM(Prefix)HB-150-90R600-SA	850	850
	200	PF(Prefix)HB-200-90R600-SA	900	900	PM(Prefix)HB-200-90R600-SA	900	900
	300	PF(Prefix)HB-300-90R600-SA	1000	1000	PM(Prefix)HB-300-90R600-SA	1000	1000
	400	PF(Prefix)HB-400-90R600-SA	1100	1100	PM(Prefix)HB-400-90R600-SA	1100	1100
	500	PF(Prefix)HB-500-90R600-SA	1200	1200	PM(Prefix)HB-500-90R600-SA	1200	1200
900	600	PF(Prefix)HB-600-90R600-SA	1300	1300	PM(Prefix)HB-600-90R600-SA	1300	1300
	900	PF(Prefix)HB-900-90R600-SA	1600	1600	PM(Prefix)HB-900-90R600-SA	1600	1600
	50	PF(Prefix)HB-050-90R900-SA	1050	1050	PM(Prefix)HB-050-90R900-SA	1050	1050
	100	PF(Prefix)HB-100-90R900-SA	1100	1100	PM(Prefix)HB-100-90R900-SA	1100	1100
	150	PF(Prefix)HB-150-90R900-SA	1150	1150	PM(Prefix)HB-150-90R900-SA	1150	1150
	200	PF(Prefix)HB-200-90R900-SA	1200	1200	PM(Prefix)HB-200-90R900-SA	1200	1200
	300	PF(Prefix)HB-300-90R900-SA	1300	1300	PM(Prefix)HB-300-90R900-SA	1300	1300
	400	PF(Prefix)HB-400-90R900-SA	1400	1400	PM(Prefix)HB-400-90R900-SA	1400	1400
900	500	PF(Prefix)HB-500-90R900-SA	1500	1500	PM(Prefix)HB-500-90R900-SA	1500	1500
	600	PF(Prefix)HB-600-90R900-SA	1600	1600	PM(Prefix)HB-600-90R900-SA	1600	1600
	900	PF(Prefix)HB-900-90R900-SA	1900	1900	PM(Prefix)HB-900-90R900-SA	1900	1900

(Prefix) See page 89 for catalog number prefix and splice plate hole information.

Width dimensions are to inside wall. Manufacturing tolerances apply to all dimensions.

All dimensions are in millimeters unless otherwise specified.

# Cable Tray - Fittings - Southern Asia

## Horizontal Bends 60° (HB)

Splice plates not supplied with fittings.  
Order standard splice plates separately from page 85.  
One (1) pair required to connect to system.

Note:

Perforated slot dimensions and patterns may vary depending on tray size and type.  
(R) 180° return flange not available on 025 tray heights.

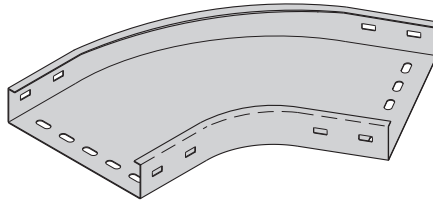

60° Horizontal Bend Formed (C) Shown

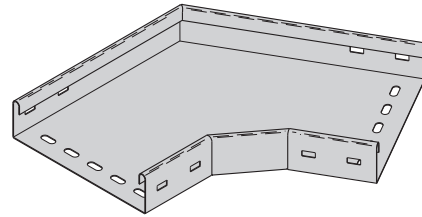
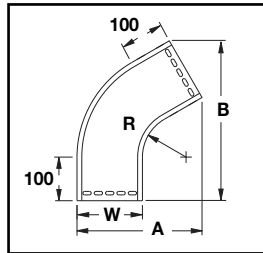

60° Horizontal Bend Mitered (R) Shown

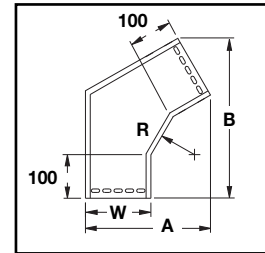

Bend Radius R mm	Tray Width W mm	60° Horizontal Bend Dimensions					
		Formed Radius Fittings			Mitered Radius Fittings		
		Catalog No.	A mm	B mm	Catalog No.	A mm	B mm
300	50	PF(Prefix)HB-050-60R300-SA	287	453	PM(Prefix)HB-050-60R300-SA	287	453
	100	PF(Prefix)HB-100-60R300-SA	337	496	PM(Prefix)HB-100-60R300-SA	337	496
	150	PF(Prefix)HB-150-60R300-SA	387	540	PM(Prefix)HB-150-60R300-SA	387	540
	200	PF(Prefix)HB-200-60R300-SA	437	583	PM(Prefix)HB-200-60R300-SA	437	583
	300	PF(Prefix)HB-300-60R300-SA	537	670	PM(Prefix)HB-300-60R300-SA	537	670
	400	PF(Prefix)HB-400-60R300-SA	637	756	PM(Prefix)HB-400-60R300-SA	637	756
	500	PF(Prefix)HB-500-60R300-SA	737	843	PM(Prefix)HB-500-60R300-SA	737	843
	600	PF(Prefix)HB-600-60R300-SA	837	929	PM(Prefix)HB-600-60R300-SA	837	929
	900	PF(Prefix)HB-900-60R300-SA	1137	1189	PM(Prefix)HB-900-60R300-SA	1137	1189
600	50	PF(Prefix)HB-050-60R600-SA	437	713	PM(Prefix)HB-050-60R600-SA	437	713
	100	PF(Prefix)HB-100-60R600-SA	487	756	PM(Prefix)HB-100-60R600-SA	487	756
	150	PF(Prefix)HB-150-60R600-SA	537	800	PM(Prefix)HB-150-60R600-SA	537	800
	200	PF(Prefix)HB-200-60R600-SA	587	843	PM(Prefix)HB-200-60R600-SA	587	843
	300	PF(Prefix)HB-300-60R600-SA	687	929	PM(Prefix)HB-300-60R600-SA	687	929
	400	PF(Prefix)HB-400-60R600-SA	787	1016	PM(Prefix)HB-400-60R600-SA	787	1016
	500	PF(Prefix)HB-500-60R600-SA	887	1103	PM(Prefix)HB-500-60R600-SA	887	1103
	600	PF(Prefix)HB-600-60R600-SA	987	1189	PM(Prefix)HB-600-60R600-SA	987	1189
	900	PF(Prefix)HB-900-60R600-SA	1287	1449	PM(Prefix)HB-900-60R600-SA	1287	1449
900	50	PF(Prefix)HB-050-60R900-SA	587	973	PM(Prefix)HB-050-60R900-SA	587	973
	100	PF(Prefix)HB-100-60R900-SA	637	1016	PM(Prefix)HB-100-60R900-SA	637	1016
	150	PF(Prefix)HB-150-60R900-SA	687	1053	PM(Prefix)HB-150-60R900-SA	687	1053
	200	PF(Prefix)HB-200-60R900-SA	737	1103	PM(Prefix)HB-200-60R900-SA	737	1103
	300	PF(Prefix)HB-300-60R900-SA	837	1189	PM(Prefix)HB-300-60R900-SA	837	1189
	400	PF(Prefix)HB-400-60R900-SA	967	1276	PM(Prefix)HB-400-60R900-SA	967	1276
	500	PF(Prefix)HB-500-60R900-SA	1037	1362	PM(Prefix)HB-500-60R900-SA	1037	1362
	600	PF(Prefix)HB-600-60R900-SA	1137	1449	PM(Prefix)HB-600-60R900-SA	1137	1449
	900	PF(Prefix)HB-900-60R900-SA	1437	1709	PM(Prefix)HB-900-60R900-SA	1437	1709

(Prefix) See page 89 for catalog number prefix and splice plate hole information.

Width dimensions are to inside wall. Manufacturing tolerances apply to all dimensions.

# Cable Tray - Fittings - Southern Asia

Note:

Perforated slot dimensions and patterns may vary depending on tray size and type.  
(R) 180° return flange not available on 025 tray heights.

## Horizontal Bends 45° (HB)

Splice plates not supplied with fittings.  
Order standard splice plates separately from page 85.  
One (1) pair required to connect to system.

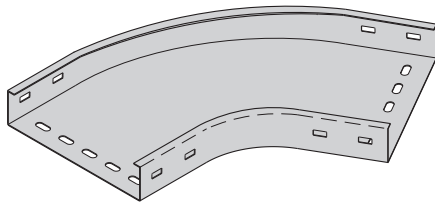

45° Horizontal Bend Formed (C) Shown

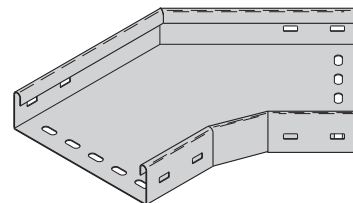
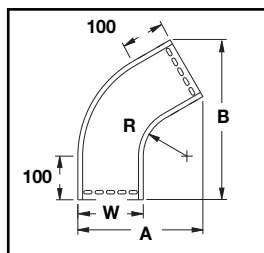

45° Horizontal Bend Mitered (R) Shown

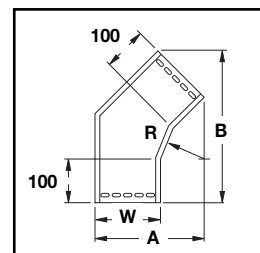

Bend Radius R mm	Tray Width W mm	45° Horizontal Bend Dimensions					
		Formed Radius Fittings			Mitered Radius Fittings		
		Catalog No.	A mm	B mm	Catalog No.	A mm	B mm
300	50	PF(Prefix)HB-050-45R300-SA	209	418	PM(Prefix)HB-050-45R300-SA	209	418
	100	PF(Prefix)HB-100-45R300-SA	259	454	PM(Prefix)HB-100-45R300-SA	259	454
	150	PF(Prefix)HB-150-45R300-SA	309	489	PM(Prefix)HB-150-45R300-SA	309	489
	200	PF(Prefix)HB-200-45R300-SA	359	524	PM(Prefix)HB-200-45R300-SA	459	595
	300	PF(Prefix)HB-300-45R300-SA	459	595	PM(Prefix)HB-300-45R300-SA	459	595
	400	PF(Prefix)HB-400-45R300-SA	559	666	PM(Prefix)HB-400-45R300-SA	559	666
	500	PF(Prefix)HB-500-45R300-SA	659	736	PM(Prefix)HB-500-45R300-SA	659	736
	600	PF(Prefix)HB-600-45R300-SA	759	807	PM(Prefix)HB-600-45R300-SA	759	807
	900	PF(Prefix)HB-900-45R300-SA	1059	1019	PM(Prefix)HB-900-45R300-SA	1059	1019
600	50	PF(Prefix)HB-050-45R600-SA	296	630	PM(Prefix)HB-050-45R600-SA	296	630
	100	PF(Prefix)HB-100-45R600-SA	346	666	PM(Prefix)HB-100-45R600-SA	346	666
	150	PF(Prefix)HB-150-45R600-SA	396	701	PM(Prefix)HB-150-45R600-SA	396	701
	200	PF(Prefix)HB-200-45R600-SA	446	736	PM(Prefix)HB-200-45R600-SA	446	736
	300	PF(Prefix)HB-300-45R600-SA	546	807	PM(Prefix)HB-300-45R600-SA	546	807
	400	PF(Prefix)HB-400-45R600-SA	646	878	PM(Prefix)HB-400-45R600-SA	646	878
	500	PF(Prefix)HB-500-45R600-SA	746	949	PM(Prefix)HB-500-45R600-SA	746	949
	600	PF(Prefix)HB-600-45R600-SA	846	1019	PM(Prefix)HB-600-45R600-SA	846	1019
	900	PF(Prefix)HB-900-45R600-SA	1146	1231	PM(Prefix)HB-900-45R600-SA	1146	1231
900	50	PF(Prefix)HB-050-45R900-SA	384	842	PM(Prefix)HB-050-45R900-SA	384	842
	100	PF(Prefix)HB-100-45R900-SA	434	878	PM(Prefix)HB-100-45R900-SA	434	878
	150	PF(Prefix)HB-150-45R900-SA	484	913	PM(Prefix)HB-150-45R900-SA	484	913
	200	PF(Prefix)HB-200-45R900-SA	534	949	PM(Prefix)HB-200-45R900-SA	534	949
	300	PF(Prefix)HB-300-45R900-SA	634	1019	PM(Prefix)HB-300-45R900-SA	634	1019
	400	PF(Prefix)HB-400-45R900-SA	734	1090	PM(Prefix)HB-400-45R900-SA	734	1090
	500	PF(Prefix)HB-500-45R900-SA	834	1161	PM(Prefix)HB-500-45R900-SA	834	1161
	600	PF(Prefix)HB-600-45R900-SA	934	1231	PM(Prefix)HB-600-45R900-SA	934	1231
	900	PF(Prefix)HB-900-45R900-SA	1234	1444	PM(Prefix)HB-900-45R900-SA	1234	1444

(Prefix) See page 89 for catalog number prefix and splice plate hole information.

Width dimensions are to inside wall. Manufacturing tolerances apply to all dimensions.

All dimensions are in millimeters unless otherwise specified.

# Cable Tray - Fittings - Southern Asia

## Horizontal Bends 30° (HB)

Splice plates not supplied with fittings.  
Order standard splice plates separately from page 85.  
One (1) pair required to connect to system.

Note:

Perforated slot dimensions and patterns may vary depending on tray size and type.  
(R) 180° return flange not available on 025 tray heights.

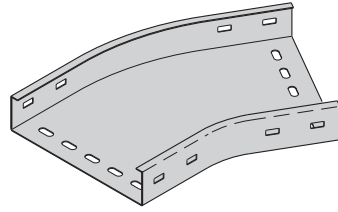

30° Horizontal Bend Formed (C) Shown

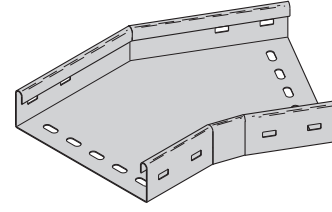
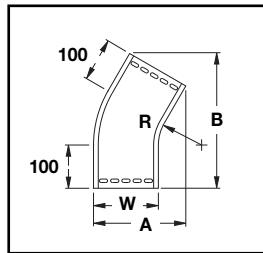

30° Horizontal Bend Mitered (R) Shown

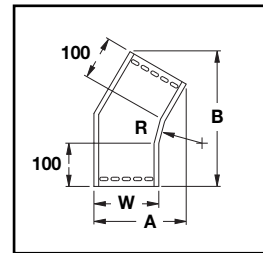

Bend Radius R mm	Tray Width W mm	30° Horizontal Bend Dimensions					
		Formed Radius Fittings			Mitered Radius Fittings		
		Catalog No.	A mm	B mm	Catalog No.	A mm	B mm
300	50	PF(Prefix)HB-050-30R300-SA	140	362	PM(Prefix)HB-050-30R300-SA	140	362
	100	PF(Prefix)HB-100-30R300-SA	190	387	PM(Prefix)HB-100-30R300-SA	190	387
	150	PF(Prefix)HB-150-30R300-SA	240	412	PM(Prefix)HB-150-30R300-SA	240	412
	200	PF(Prefix)HB-200-30R300-SA	290	637	PM(Prefix)HB-200-30R300-SA	290	637
	300	PF(Prefix)HB-300-30R300-SA	390	487	PM(Prefix)HB-300-30R300-SA	390	487
	400	PF(Prefix)HB-400-30R300-SA	490	537	PM(Prefix)HB-400-30R300-SA	490	537
	500	PF(Prefix)HB-500-30R300-SA	590	587	PM(Prefix)HB-500-30R300-SA	590	587
	600	PF(Prefix)HB-600-30R300-SA	690	637	PM(Prefix)HB-600-30R300-SA	690	637
	900	PF(Prefix)HB-900-30R300-SA	990	787	PM(Prefix)HB-900-30R300-SA	990	787
600	50	PF(Prefix)HB-050-30R600-SA	180	512	PM(Prefix)HB-050-30R600-SA	180	512
	100	PF(Prefix)HB-100-30R600-SA	230	537	PM(Prefix)HB-100-30R600-SA	230	537
	150	PF(Prefix)HB-150-30R600-SA	280	562	PM(Prefix)HB-150-30R600-SA	280	562
	200	PF(Prefix)HB-200-30R600-SA	330	587	PM(Prefix)HB-200-30R600-SA	330	587
	300	PF(Prefix)HB-300-30R600-SA	430	637	PM(Prefix)HB-300-30R600-SA	430	637
	400	PF(Prefix)HB-400-30R600-SA	530	687	PM(Prefix)HB-400-30R600-SA	530	687
	500	PF(Prefix)HB-500-30R600-SA	630	737	PM(Prefix)HB-500-30R600-SA	630	737
	600	PF(Prefix)HB-600-30R600-SA	730	787	PM(Prefix)HB-600-30R600-SA	730	787
	900	PF(Prefix)HB-900-30R600-SA	1030	937	PM(Prefix)HB-900-30R600-SA	1030	937
900	50	PF(Prefix)HB-050-30R900-SA	221	662	PM(Prefix)HB-050-30R900-SA	221	662
	100	PF(Prefix)HB-100-30R900-SA	271	687	PM(Prefix)HB-100-30R900-SA	271	687
	150	PF(Prefix)HB-150-30R900-SA	321	712	PM(Prefix)HB-150-30R900-SA	321	712
	200	PF(Prefix)HB-200-30R900-SA	371	737	PM(Prefix)HB-200-30R900-SA	371	737
	300	PF(Prefix)HB-300-30R900-SA	471	787	PM(Prefix)HB-300-30R900-SA	471	787
	400	PF(Prefix)HB-400-30R900-SA	571	837	PM(Prefix)HB-400-30R900-SA	571	837
	500	PF(Prefix)HB-500-30R900-SA	671	887	PM(Prefix)HB-500-30R900-SA	671	887
	600	PF(Prefix)HB-600-30R900-SA	771	937	PM(Prefix)HB-600-30R900-SA	771	937
	900	PF(Prefix)HB-900-30R900-SA	1071	1087	PM(Prefix)HB-900-30R900-SA	1071	1087

(Prefix) See page 89 for catalog number prefix and splice plate hole information.

Width dimensions are to inside wall. Manufacturing tolerances apply to all dimensions.

# Cable Tray - Fittings - Southern Asia

## Horizontal Tee (HT)

Note:

Perforated slot dimensions and patterns may vary depending on tray size and type.  
(R) 180° return flange not available on 025 tray heights.

Splice plates not supplied with fittings.  
Order standard splice plates separately from page 85.  
Two (2) pair required to connect to system.

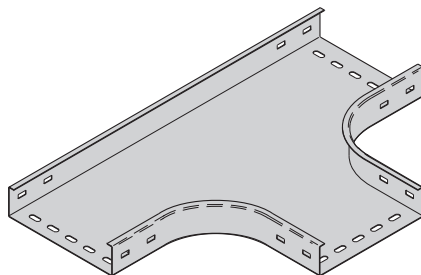

Horizontal Tee Formed (C) Shown

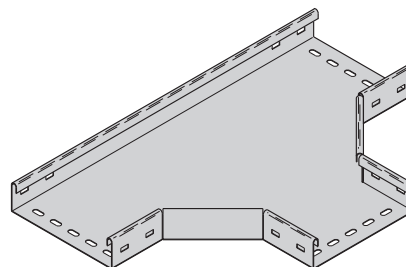
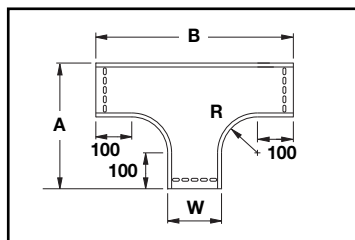

Horizontal Tee Mitered (R) Shown

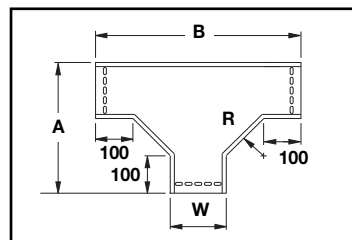

Bend Radius R mm	Tray Width W mm	Horizontal Tee Dimensions					
		Formed Radius Fittings			Mitered Radius Fittings		
		Catalog No.	A mm	B mm	Catalog No.	A mm	B mm
300	50	PF(Prefix)HT-050-R300-SA	450	850	PM(Prefix)HT-050-R300-SA	450	850
	100	PF(Prefix)HT-100-R300-SA	500	900	PM(Prefix)HT-100-R300-SA	500	900
	150	PF(Prefix)HT-150-R300-SA	550	950	PM(Prefix)HT-150-R300-SA	550	950
	200	PF(Prefix)HT-200-R300-SA	600	1000	PM(Prefix)HT-200-R300-SA	600	1000
	300	PF(Prefix)HT-300-R300-SA	700	1100	PM(Prefix)HT-300-R300-SA	700	1100
	400	PF(Prefix)HT-400-R300-SA	800	1200	PM(Prefix)HT-400-R300-SA	800	1200
	500	PF(Prefix)HT-500-R300-SA	900	1300	PM(Prefix)HT-500-R300-SA	900	1300
	600	PF(Prefix)HT-600-R300-SA	1000	1400	PM(Prefix)HT-600-R300-SA	1000	1400
600	900	PF(Prefix)HT-900-R300-SA	1300	1700	PM(Prefix)HT-900-R300-SA	1300	1700
	50	PF(Prefix)HT-050-R600-SA	750	1450	PM(Prefix)HT-050-R600-SA	750	1450
	100	PF(Prefix)HT-100-R600-SA	800	1500	PM(Prefix)HT-100-R600-SA	800	1500
	150	PF(Prefix)HT-150-R600-SA	850	1550	PM(Prefix)HT-150-R600-SA	850	1550
	200	PF(Prefix)HT-200-R600-SA	900	1600	PM(Prefix)HT-200-R600-SA	900	1600
	300	PF(Prefix)HT-300-R600-SA	1000	1700	PM(Prefix)HT-300-R600-SA	1000	1700
	400	PF(Prefix)HT-400-R600-SA	1100	1800	PM(Prefix)HT-400-R600-SA	1100	1800
	500	PF(Prefix)HT-500-R600-SA	1200	1900	PM(Prefix)HT-500-R600-SA	1200	1900
900	600	PF(Prefix)HT-600-R600-SA	1300	2000	PM(Prefix)HT-600-R600-SA	1300	2000
	900	PF(Prefix)HT-900-R600-SA	1600	2300	PM(Prefix)HT-900-R600-SA	1600	2300
	50	PF(Prefix)HT-050-R900-SA	1050	2050	PM(Prefix)HT-050-R900-SA	1050	2050
	100	PF(Prefix)HT-100-R900-SA	1100	2100	PM(Prefix)HT-100-R900-SA	1100	2100
	150	PF(Prefix)HT-150-R900-SA	1150	2150	PM(Prefix)HT-150-R900-SA	1150	2150
	200	PF(Prefix)HT-200-R900-SA	1200	2200	PM(Prefix)HT-200-R900-SA	1200	2200
	300	PF(Prefix)HT-300-R900-SA	1300	2300	PM(Prefix)HT-300-R900-SA	1300	2300
	400	PF(Prefix)HT-400-R900-SA	1400	2400	PM(Prefix)HT-400-R900-SA	1400	2400
500	PF(Prefix)HT-500-R900-SA	1500	2500	PM(Prefix)HT-500-R900-SA	1500	2500	
600	PF(Prefix)HT-600-R900-SA	1600	2600	PM(Prefix)HT-600-R900-SA	1600	2600	
900	PF(Prefix)HT-900-R900-SA	1900	2900	PM(Prefix)HT-900-R900-SA	1900	2900	

(Prefix) See page 89 for catalog number prefix and splice plate hole information.

Width dimensions are to inside wall. Manufacturing tolerances apply to all dimensions.

All dimensions are in millimeters unless otherwise specified.

# Cable Tray - Fittings - Southern Asia

## Horizontal Cross (HX)

Splice plates not supplied with fittings.  
Order standard splice plates separately from page 85.  
Three (3) pair required to connect to system.

Note:

Perforated slot dimensions and patterns may vary depending on tray size and type.  
(R) 180° return flange not available on 025 tray heights.

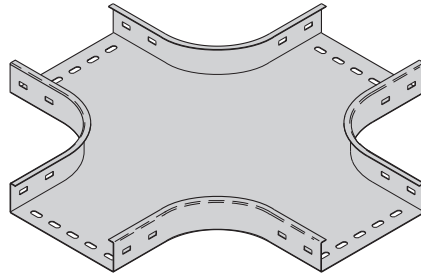

Horizontal Cross  
Formed (C) Shown

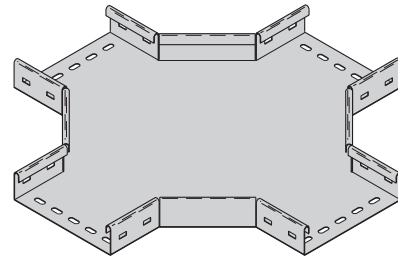
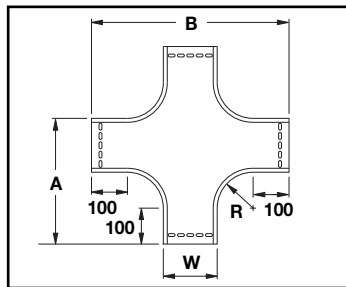

Horizontal Cross  
Mitered (R) Shown

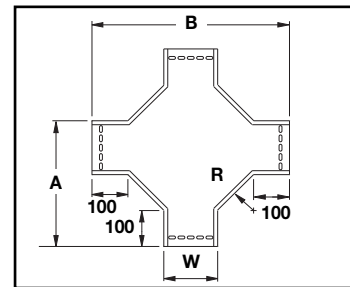

Bend Radius R mm	Tray Width W mm	Horizontal Cross Dimensions					
		Formed Radius Fittings			Mitered Radius Fittings		
		Catalog No.	A mm	B mm	Catalog No.	A mm	B mm
300	50	PF(Prefix)HX-050-R300-SA	450	850	PM(Prefix)HX-050-R300-SA	450	850
	100	PF(Prefix)HX-100-R300-SA	500	900	PM(Prefix)HX-100-R300-SA	500	900
	150	PF(Prefix)HX-150-R300-SA	550	950	PM(Prefix)HX-150-R300-SA	550	950
	200	PF(Prefix)HX-200-R300-SA	600	1000	PM(Prefix)HX-200-R300-SA	600	1000
	300	PF(Prefix)HX-300-R300-SA	700	1100	PM(Prefix)HX-300-R300-SA	700	1100
	400	PF(Prefix)HX-400-R300-SA	800	1200	PM(Prefix)HX-400-R300-SA	800	1200
	500	PF(Prefix)HX-500-R300-SA	900	1300	PM(Prefix)HX-500-R300-SA	900	1300
	600	PF(Prefix)HX-600-R300-SA	1000	1400	PM(Prefix)HX-600-R300-SA	1000	1400
	900	PF(Prefix)HX-900-R300-SA	1300	1700	PM(Prefix)HX-900-R300-SA	1300	1700
600	50	PF(Prefix)HX-050-R600-SA	750	1450	PM(Prefix)HX-050-R600-SA	750	1450
	100	PF(Prefix)HX-100-R600-SA	800	1500	PM(Prefix)HX-100-R600-SA	800	1500
	150	PF(Prefix)HX-150-R600-SA	850	1550	PM(Prefix)HX-150-R600-SA	850	1550
	200	PF(Prefix)HX-200-R600-SA	900	1600	PM(Prefix)HX-200-R600-SA	900	1600
	300	PF(Prefix)HX-300-R600-SA	1000	1700	PM(Prefix)HX-300-R600-SA	1000	1700
	400	PF(Prefix)HX-400-R600-SA	1100	1800	PM(Prefix)HX-400-R600-SA	1100	1800
	500	PF(Prefix)HX-500-R600-SA	1200	1900	PM(Prefix)HX-500-R600-SA	1200	1900
	600	PF(Prefix)HX-600-R600-SA	1300	2000	PM(Prefix)HX-600-R600-SA	1300	2000
	900	PF(Prefix)HX-900-R600-SA	1600	2300	PM(Prefix)HX-900-R600-SA	1600	2300
900	50	PF(Prefix)HX-050-R900-SA	1050	2050	PM(Prefix)HX-050-R900-SA	1050	2050
	100	PF(Prefix)HX-100-R900-SA	1100	2100	PM(Prefix)HX-100-R900-SA	1100	2100
	150	PF(Prefix)HX-150-R900-SA	1150	2150	PM(Prefix)HX-150-R900-SA	1150	2150
	200	PF(Prefix)HX-200-R900-SA	1200	2200	PM(Prefix)HX-200-R900-SA	1200	2200
	300	PF(Prefix)HX-300-R900-SA	1300	2300	PM(Prefix)HX-300-R900-SA	1300	2300
	400	PF(Prefix)HX-400-R900-SA	1400	2400	PM(Prefix)HX-400-R900-SA	1400	2400
	500	PF(Prefix)HX-500-R900-SA	1500	2500	PM(Prefix)HX-500-R900-SA	1500	2500
	600	PF(Prefix)HX-600-R900-SA	1600	2600	PM(Prefix)HX-600-R900-SA	1600	2600
	900	PF(Prefix)HX-900-R900-SA	1900	2900	PM(Prefix)HX-900-R900-SA	1900	2900

(Prefix) See page 89 for catalog number prefix and splice plate hole information.

Width dimensions are to inside wall. Manufacturing tolerances apply to all dimensions.

# Cable Tray - Fittings - Southern Asia

## Reducer Part Numbering

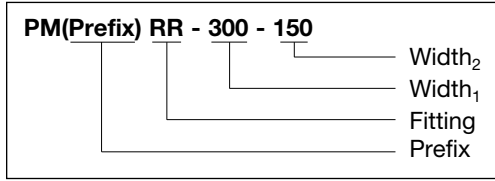

Note:

Perforated slot dimensions and patterns may vary depending on tray size and type.  
(R) 180° return flange not available on 025 tray heights.

## Left Reducer (LR) Straight Reducer (SR) Right Reducer (RR)

Splice plates not supplied with fittings.  
Order standard splice plates separately from page 85.  
One (1) pair required to connect to system.

Mitered \*\*

Tray Width		Left Hand Reducer		Straight Reducer		Right Hand Reducer	
W <sub>1</sub>	W <sub>2</sub>	Catalog No.	A	Catalog No.	A	Catalog No.	A
mm	mm		mm		mm		mm
100	50	PM(Prefix)-LR-100-050-SA	300	PM(Prefix)-SR-100-050-SA	300	PM(Prefix)-RR-100-050-SA	300
150	50	PM(Prefix)-LR-150-050-SA	300	PM(Prefix)-SR-150-050-SA	300	PM(Prefix)-RR-150-050-SA	300
	100	PM(Prefix)-LR-150-100-SA	300	PM(Prefix)-SR-150-100-SA	300	PM(Prefix)-RR-150-100-SA	300
200	50	PM(Prefix)-LR-200-050-SA	300	PM(Prefix)-SR-200-050-SA	300	PM(Prefix)-RR-200-050-SA	300
	100	PM(Prefix)-LR-200-100-SA	300	PM(Prefix)-SR-200-100-SA	300	PM(Prefix)-RR-200-100-SA	300
	150	PM(Prefix)-LR-200-150-SA	300	PM(Prefix)-SR-200-150-SA	300	PM(Prefix)-RR-200-150-SA	300
300	50	PM(Prefix)-LR-300-050-SA	300	PM(Prefix)-SR-300-050-SA	300	PM(Prefix)-RR-300-050-SA	300
	100	PM(Prefix)-LR-300-100-SA	300	PM(Prefix)-SR-300-100-SA	300	PM(Prefix)-RR-300-100-SA	300
	150	PM(Prefix)-LR-300-150-SA	300	PM(Prefix)-SR-300-150-SA	300	PM(Prefix)-RR-300-150-SA	300
	200	PM(Prefix)-LR-300-200-SA	300	PM(Prefix)-SR-300-200-SA	300	PM(Prefix)-RR-300-200-SA	300
400	50	PM(Prefix)-LR-400-050-SA	300	PM(Prefix)-SR-400-050-SA	300	PM(Prefix)-RR-400-050-SA	300
	100	PM(Prefix)-LR-400-100-SA	300	PM(Prefix)-SR-400-100-SA	300	PM(Prefix)-RR-400-100-SA	300
	150	PM(Prefix)-LR-400-150-SA	300	PM(Prefix)-SR-400-150-SA	300	PM(Prefix)-RR-400-150-SA	300
	200	PM(Prefix)-LR-400-200-SA	300	PM(Prefix)-SR-400-200-SA	300	PM(Prefix)-RR-400-200-SA	300
	300	PM(Prefix)-LR-400-300-SA	300	PM(Prefix)-SR-400-300-SA	300	PM(Prefix)-RR-400-300-SA	300
500	50	PM(Prefix)-LR-500-050-SA	300	PM(Prefix)-SR-500-050-SA	300	PM(Prefix)-RR-500-050-SA	300
	100	PM(Prefix)-LR-500-100-SA	300	PM(Prefix)-SR-500-100-SA	300	PM(Prefix)-RR-500-100-SA	300
	150	PM(Prefix)-LR-500-150-SA	300	PM(Prefix)-SR-500-150-SA	300	PM(Prefix)-RR-500-150-SA	300
	200	PM(Prefix)-LR-500-200-SA	300	PM(Prefix)-SR-500-200-SA	300	PM(Prefix)-RR-500-200-SA	300
	300	PM(Prefix)-LR-500-300-SA	300	PM(Prefix)-SR-500-300-SA	300	PM(Prefix)-RR-500-300-SA	300
600	400	PM(Prefix)-LR-500-400-SA	300	PM(Prefix)-SR-500-400-SA	300	PM(Prefix)-RR-500-400-SA	300
	50	PM(Prefix)-LR-600-050-SA	300	PM(Prefix)-SR-600-050-SA	300	PM(Prefix)-RR-600-050-SA	300
	100	PM(Prefix)-LR-600-100-SA	300	PM(Prefix)-SR-600-100-SA	300	PM(Prefix)-RR-600-100-SA	300
	150	PM(Prefix)-LR-600-150-SA	300	PM(Prefix)-SR-600-150-SA	300	PM(Prefix)-RR-600-150-SA	300
	200	PM(Prefix)-LR-600-200-SA	300	PM(Prefix)-SR-600-200-SA	300	PM(Prefix)-RR-600-200-SA	300
900	300	PM(Prefix)-LR-600-300-SA	300	PM(Prefix)-SR-600-300-SA	300	PM(Prefix)-RR-600-300-SA	300
	400	PM(Prefix)-LR-600-400-SA	300	PM(Prefix)-SR-600-400-SA	300	PM(Prefix)-RR-600-400-SA	300
	500	PM(Prefix)-LR-600-500-SA	300	PM(Prefix)-SR-600-500-SA	300	PM(Prefix)-RR-600-500-SA	300
	50	PM(Prefix)-LR-900-050-SA	300	PM(Prefix)-SR-900-050-SA	300	PM(Prefix)-RR-900-050-SA	300
	100	PM(Prefix)-LR-900-100-SA	300	PM(Prefix)-SR-900-100-SA	300	PM(Prefix)-RR-900-100-SA	300
900	150	PM(Prefix)-LR-900-150-SA	300	PM(Prefix)-SR-900-150-SA	300	PM(Prefix)-RR-900-150-SA	300
	200	PM(Prefix)-LR-900-200-SA	300	PM(Prefix)-SR-900-200-SA	300	PM(Prefix)-RR-900-200-SA	300
	300	PM(Prefix)-LR-900-300-SA	300	PM(Prefix)-SR-900-300-SA	300	PM(Prefix)-RR-900-300-SA	300
	400	PM(Prefix)-LR-900-400-SA	300	PM(Prefix)-SR-900-400-SA	300	PM(Prefix)-RR-900-400-SA	300
	500	PM(Prefix)-LR-900-500-SA	300	PM(Prefix)-SR-900-500-SA	300	PM(Prefix)-RR-900-500-SA	300
600	PM(Prefix)-LR-900-600-SA	300	PM(Prefix)-SR-900-600-SA	300	PM(Prefix)-RR-900-600-SA	300	

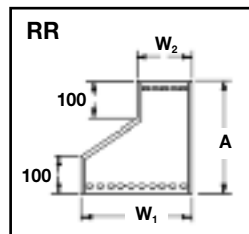
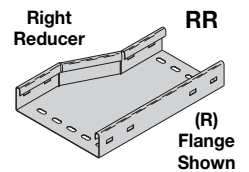
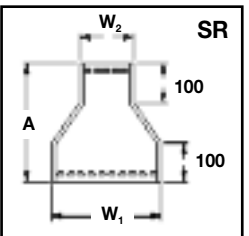
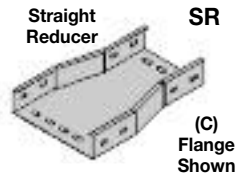
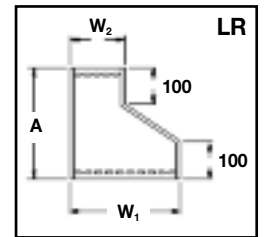
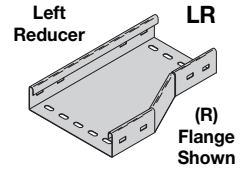

(Prefix) See page 89 for catalog number prefix and splice plate hole information.  
Width dimensions are to inside wall. Manufacturing tolerances apply to all dimensions.

\*\* Reducers are made only in the mitered style as shown

All dimensions are in millimeters unless otherwise specified.

# Cable Tray - Fittings - Southern Asia

## Vertical Bends 90° (VO, VI) Formed

Splice plates not supplied with fittings.  
Order standard splice plates separately from page 85.  
One (1) pair required to connect to system.

Note:

Perforated slot dimensions and patterns may vary depending on tray size and type.  
(R) 180° return flange not available on 025 tray heights.

90° Vertical Outside

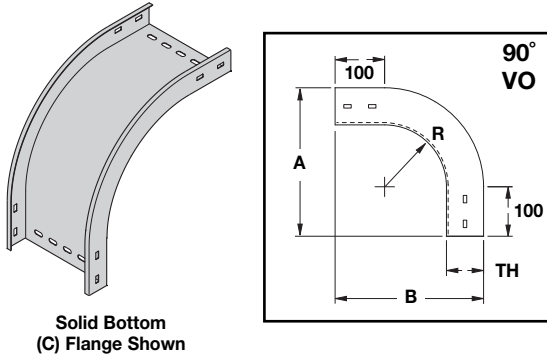

90° Vertical Inside

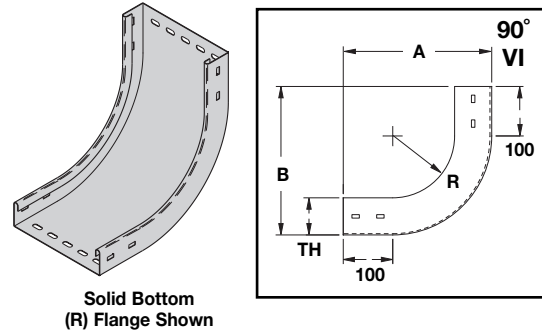

### 90° Formed \*\*\*

Bend Radius R mm	Tray Width mm	(*) Insert "VO" for Vert. Outside Bend "VI" for Vert. Inside Bend Catalog No.	VO Tray Height (TH)								VI Tray Height (TH)							
			25mm		50mm		75mm		100mm		25mm		50mm		75mm		100mm	
			A mm	B mm	A mm	B mm	A mm	B mm	A mm	B mm	A mm	B mm	A mm	B mm	A mm	B mm	A mm	B mm
300	50	PF(Prefix)(*)-050-90R300-SA																
	100	PF(Prefix)(*)-100-90R300-SA																
	150	PF(Prefix)(*)-150-90R300-SA																
	200	PF(Prefix)(*)-200-90R300-SA																
	300	PF(Prefix)(*)-300-90R300-SA	425	425	450	450	475	475	500	500	425	425	450	450	475	475	500	500
	400	PF(Prefix)(*)-400-90R300-SA																
	500	PF(Prefix)(*)-500-90R300-SA																
	600	PF(Prefix)(*)-600-90R300-SA																
600	900	PF(Prefix)(*)-900-90R300-SA	N/A	N/A							N/A	N/A						
	50	PF(Prefix)(*)-050-90R600-SA																
	100	PF(Prefix)(*)-100-90R600-SA																
	150	PF(Prefix)(*)-150-90R600-SA																
	200	PF(Prefix)(*)-200-90R600-SA																
	300	PF(Prefix)(*)-300-90R600-SA	725	725	750	750	775	775	800	800	725	725	750	750	775	775	800	800
	400	PF(Prefix)(*)-400-90R600-SA																
	500	PF(Prefix)(*)-500-90R600-SA																
900	600	PF(Prefix)(*)-600-90R600-SA																
	900	PF(Prefix)(*)-900-90R600-SA	N/A	N/A							N/A	N/A						
	50	PF(Prefix)(*)-050-90R900-SA																
	100	PF(Prefix)(*)-100-90R900-SA																
	150	PF(Prefix)(*)-150-90R900-SA																
	200	PF(Prefix)(*)-200-90R900-SA																
	300	PF(Prefix)(*)-300-90R900-SA	1025	1025	1050	1050	1075	1075	1100	1100	1025	1025	1050	1050	1075	1075	1100	1100
	400	PF(Prefix)(*)-400-90R900-SA																
900	500	PF(Prefix)(*)-500-90R900-SA																
	600	PF(Prefix)(*)-600-90R900-SA																
	900	PF(Prefix)(*)-900-90R900-SA	N/A	N/A							N/A	N/A						

(Prefix) See page 89 for catalog number prefix and splice plate hole information.

Width dimensions are to inside wall. Manufacturing tolerances apply to all dimensions.

\*\*\* Vertical inside and outside bends are made only in the formed style as shown

# Cable Tray - Fittings - Southern Asia

## Vertical Bends 60° (VO, VI) Formed

Note:

Perforated slot dimensions and patterns may vary depending on tray size and type.  
(R) 180° return flange not available on 025 tray heights.

Splice plates not supplied with fittings.  
Order standard splice plates separately from page 85.  
One (1) pair required to connect to system.

60° Vertical Outside

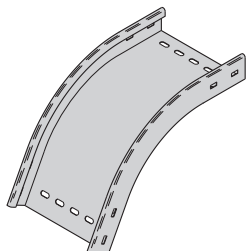

Solid Bottom  
(R) Flange Shown

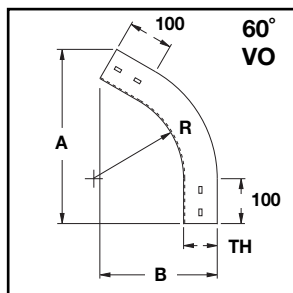

60° Vertical Inside

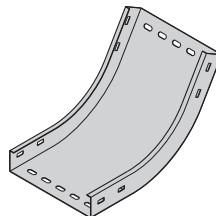

Solid Bottom  
(C) Flange Shown

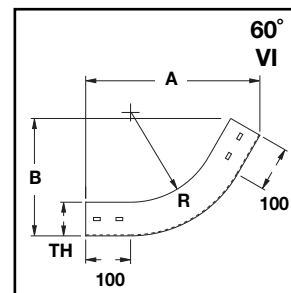

### 60° Formed \*\*\*

Bend Radius R mm	Tray Width mm	(*) Insert "VO" for Vert. Outside Bend "VI" for Vert. Inside Bend Catalog No.	VO Tray Height (TH)								VI Tray Height (TH)							
			25mm		50mm		75mm		100mm		25mm		50mm		75mm		100mm	
			A mm	B mm	A mm	B mm	A mm	B mm	A mm	B mm	A mm	B mm	A mm	B mm	A mm	B mm	A mm	B mm
300	50	PF(Prefix)(*)-050-60R300-SA																
	100	PF(Prefix)(*)-100-60R300-SA																
	150	PF(Prefix)(*)-150-60R300-SA																
	200	PF(Prefix)(*)-200-60R300-SA																
	300	PF(Prefix)(*)-300-60R300-SA	431	261	453	287	475	312	496	337	431	262	453	287	475	312	496	337
	400	PF(Prefix)(*)-400-60R300-SA																
	500	PF(Prefix)(*)-500-60R300-SA																
	600	PF(Prefix)(*)-600-60R300-SA																
	900	PF(Prefix)(*)-900-60R300-SA	N/A	N/A							N/A	N/A						
600	50	PF(Prefix)(*)-050-60R600-SA																
	100	PF(Prefix)(*)-100-60R600-SA																
	150	PF(Prefix)(*)-150-60R600-SA																
	200	PF(Prefix)(*)-200-60R600-SA																
	300	PF(Prefix)(*)-300-60R600-SA	691	411	713	437	735	462	756	487	691	412	713	437	735	462	756	487
	400	PF(Prefix)(*)-400-60R600-SA																
	500	PF(Prefix)(*)-500-60R600-SA																
	600	PF(Prefix)(*)-600-60R600-SA																
	900	PF(Prefix)(*)-900-60R600-SA	N/A	N/A							N/A	N/A						
900	50	PF(Prefix)(*)-050-60R900-SA																
	100	PF(Prefix)(*)-100-60R900-SA																
	150	PF(Prefix)(*)-150-60R900-SA																
	200	PF(Prefix)(*)-200-60R900-SA																
	300	PF(Prefix)(*)-300-60R900-SA	951	561	973	587	994	612	1016	637	951	562	973	587	994	612	1016	637
	400	PF(Prefix)(*)-400-60R900-SA																
	500	PF(Prefix)(*)-500-60R900-SA																
	600	PF(Prefix)(*)-600-60R900-SA																
	900	PF(Prefix)(*)-900-60R900-SA	N/A	N/A							N/A	N/A						

(Prefix) See page 89 for catalog number prefix and splice plate hole information.

Width dimensions are to inside wall. Manufacturing tolerances apply to all dimensions.

\*\*\* Vertical inside and outside bends are made only in the formed style as shown

All dimensions are in millimeters unless otherwise specified.

# Cable Tray - Fittings - Southern Asia

## Vertical Bends 45° (VO, VI) Formed

Splice plates not supplied with fittings.  
Order standard splice plates separately from page 85.  
One (1) pair required to connect to system.

Note:

Perforated slot dimensions and patterns may vary depending on tray size and type.  
(R) 180° return flange not available on 025 tray heights.

45° Vertical Outside

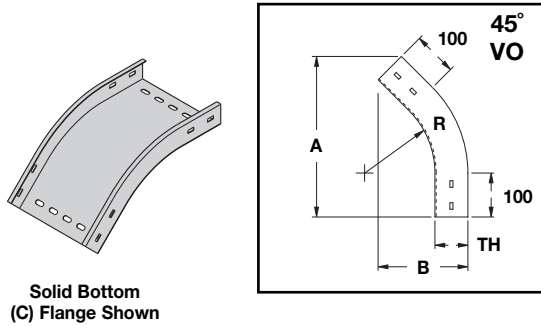

45° Vertical Inside

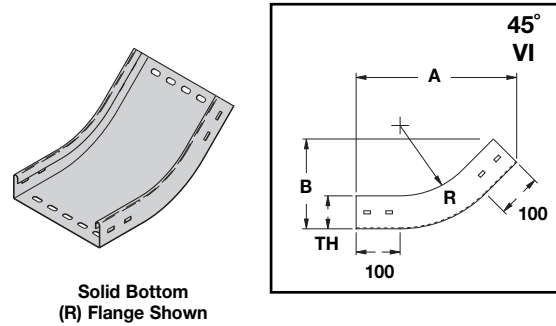

### 45° Formed \*\*\*

Bend Radius R mm	Tray Width mm	(*) Insert "VO" for Vert. Outside Bend "VI" for Vert. Inside Bend Catalog No.	VO Tray Height (TH)								VI Tray Height (TH)							
			25mm		50mm		75mm		100mm		25mm		50mm		75mm		100mm	
			A mm	B mm	A mm	B mm	A mm	B mm	A mm	B mm	A mm	B mm	A mm	B mm	A mm	B mm	A mm	B mm
300	50	PF(Prefix)(*)-050-45R300-SA																
	100	PF(Prefix)(*)-100-45R300-SA																
	150	PF(Prefix)(*)-150-45R300-SA																
	200	PF(Prefix)(*)-200-45R300-SA																
	300	PF(Prefix)(*)-300-45R300-SA	401	184	418	209	436	234	454	259	401	184	418	209	436	234	454	259
	400	PF(Prefix)(*)-400-45R300-SA																
	500	PF(Prefix)(*)-500-45R300-SA																
	600	PF(Prefix)(*)-600-45R300-SA																
	900	PF(Prefix)(*)-900-45R300-SA	N/A	N/A							N/A	N/A						
600	50	PF(Prefix)(*)-050-45R600-SA																
	100	PF(Prefix)(*)-100-45R600-SA																
	150	PF(Prefix)(*)-150-45R600-SA																
	200	PF(Prefix)(*)-200-45R600-SA																
	300	PF(Prefix)(*)-300-45R600-SA	613	271	630	296	648	321	666	346	613	271	630	296	648	321	666	346
	400	PF(Prefix)(*)-400-45R600-SA																
	500	PF(Prefix)(*)-500-45R600-SA																
	600	PF(Prefix)(*)-600-45R600-SA																
	900	PF(Prefix)(*)-900-45R600-SA	N/A	N/A							N/A	N/A						
900	50	PF(Prefix)(*)-050-45R900-SA																
	100	PF(Prefix)(*)-100-45R900-SA																
	150	PF(Prefix)(*)-150-45R900-SA																
	200	PF(Prefix)(*)-200-45R900-SA																
	300	PF(Prefix)(*)-300-45R900-SA	825	359	842	384	860	409	878	434	825	359	842	384	860	409	878	434
	400	PF(Prefix)(*)-400-45R900-SA																
	500	PF(Prefix)(*)-500-45R900-SA																
	600	PF(Prefix)(*)-600-45R900-SA																
	900	PF(Prefix)(*)-900-45R900-SA	N/A	N/A							N/A	N/A						

(Prefix) See page 89 for catalog number prefix and splice plate hole information.

Width dimensions are to inside wall. Manufacturing tolerances apply to all dimensions.

\*\*\* Vertical inside and outside bends are made only in the formed style as shown

# Cable Tray - Fittings - Southern Asia

## Vertical Bends 30° (VO, VI) Formed

Note:

Perforated slot dimensions and patterns may vary depending on tray size and type.  
(R) 180° return flange not available on 025 tray heights.

Splice plates not supplied with fittings.  
Order standard splice plates separately from page 85.  
One (1) pair required to connect to system.

30° Vertical Outside

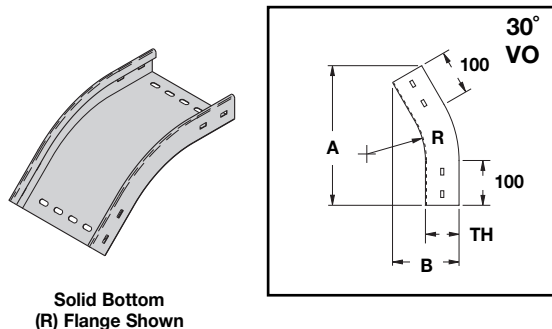

Solid Bottom  
(R) Flange Shown

30° Vertical Inside

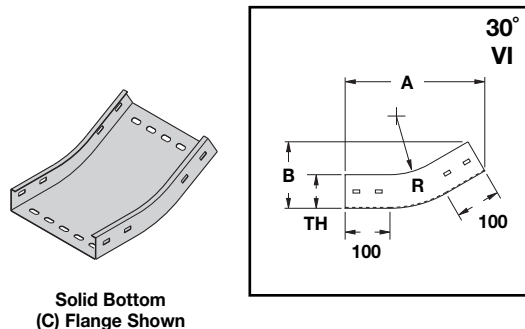

Solid Bottom  
(C) Flange Shown

### 30° Formed \*\*\*

Bend Radius R mm	Tray Width mm	(*) Insert "VO" for Vert. Outside Bend "VI" for Vert. Inside Bend Catalog No.	VO Tray Height (TH)								VI Tray Height (TH)							
			25mm		50mm		75mm		100mm		25mm		50mm		75mm		100mm	
			A mm	B mm	A mm	B mm	A mm	B mm	A mm	B mm	A mm	B mm	A mm	B mm	A mm	B mm	A mm	B mm
300	50	PF(Prefix)(*)-050-30R300-SA																
	100	PF(Prefix)(*)-100-30R300-SA																
	150	PF(Prefix)(*)-150-30R300-SA																
	200	PF(Prefix)(*)-200-30R300-SA																
	300	PF(Prefix)(*)-300-30R300-SA	349	115	362	140	374	165	387	190	349	115	362	140	374	165	387	190
	400	PF(Prefix)(*)-400-30R300-SA																
	500	PF(Prefix)(*)-500-30R300-SA																
	600	PF(Prefix)(*)-600-30R300-SA																
	900	PF(Prefix)(*)-900-30R300-SA	N/A	N/A							N/A	N/A						
600	50	PF(Prefix)(*)-050-30R600-SA																
	100	PF(Prefix)(*)-100-30R600-SA																
	150	PF(Prefix)(*)-150-30R600-SA																
	200	PF(Prefix)(*)-200-30R600-SA																
	300	PF(Prefix)(*)-300-30R600-SA	499	155	512	180	524	205	537	230	499	155	512	180	524	205	537	230
	400	PF(Prefix)(*)-400-30R600-SA																
	500	PF(Prefix)(*)-500-30R600-SA																
	600	PF(Prefix)(*)-600-30R600-SA																
	900	PF(Prefix)(*)-900-30R600-SA	N/A	N/A							N/A	N/A						
900	50	PF(Prefix)(*)-050-30R900-SA																
	100	PF(Prefix)(*)-100-30R900-SA																
	150	PF(Prefix)(*)-150-30R900-SA																
	200	PF(Prefix)(*)-200-30R900-SA																
	300	PF(Prefix)(*)-300-30R900-SA	649	196	662	221	674	246	687	271	649	196	662	221	674	246	687	271
	400	PF(Prefix)(*)-400-30R900-SA																
	500	PF(Prefix)(*)-500-30R900-SA																
	600	PF(Prefix)(*)-600-30R900-SA																
	900	PF(Prefix)(*)-900-30R900-SA	N/A	N/A							N/A	N/A						

(Prefix) See page 89 for catalog number prefix and splice plate hole information.

Width dimensions are to inside wall. Manufacturing tolerances apply to all dimensions.

\*\*\* Vertical inside and outside bends are made only in the formed style as shown

All dimensions are in millimeters unless otherwise specified.

## Straight Section Covers

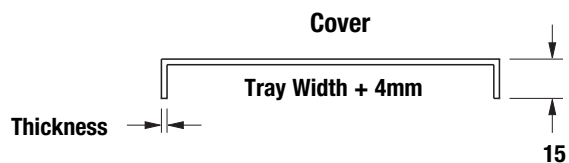
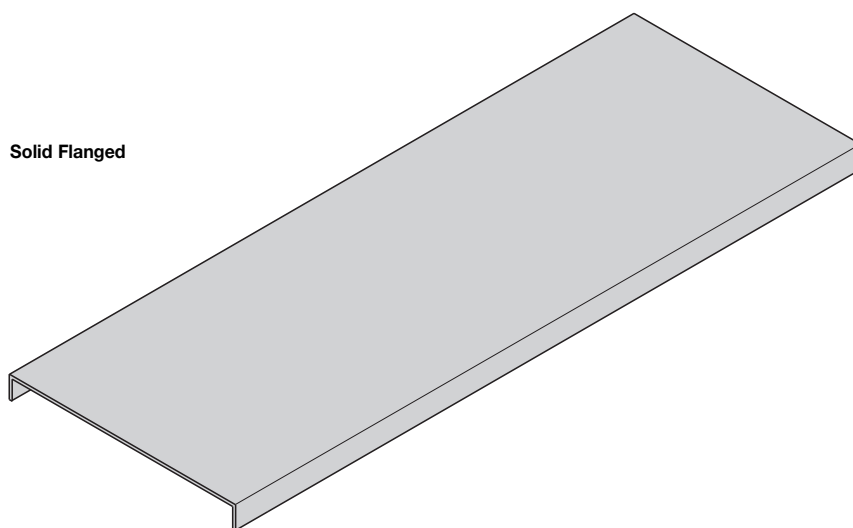

**A full range of covers is available for straight sections.**

**Solid flanged covers** should be used when maximum enclosure of the cable is desired and no accumulation of heat is expected.

**Flanged covers** have a 15mm flange.

Cover clamps are not included with the cover and must be ordered separately.

## Straight Section Covers

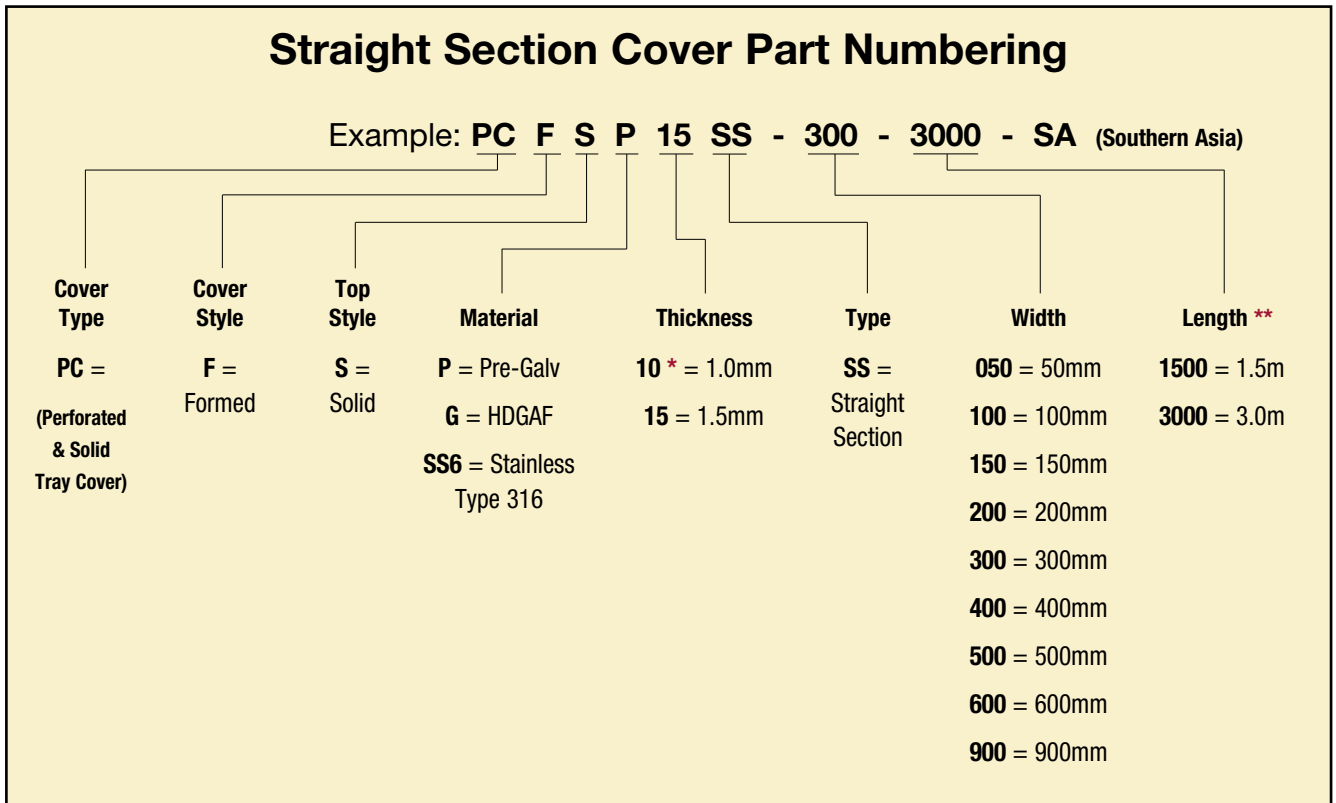

\* 1.0mm thickness is only available in widths up to and including 300 (300mm).

\*\* All G (galvanized steel) covers only available in 1500 (1.5m) lengths.  
All 900 (900mm) widths only available in 1500 (1.5m) lengths.

## Fitting Covers

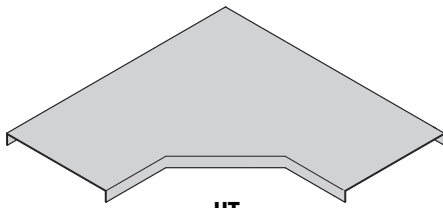

**HT**  
Horizontal Bend  
Mitered Shown

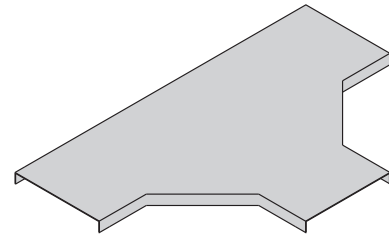

**HT**  
Horizontal Tee  
Mitered Shown

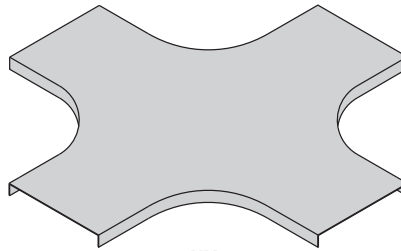

**HX**  
Horizontal Cross  
Formed Shown

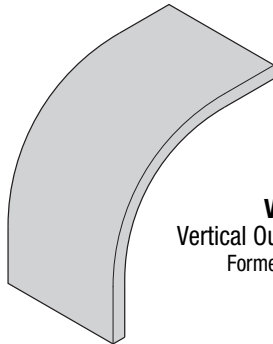

**VO**  
Vertical Outside Bend  
Formed Only

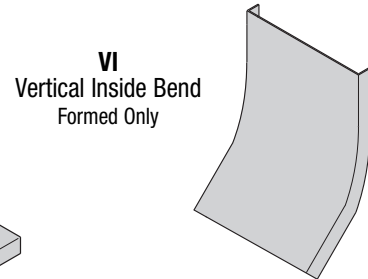

**VI**  
Vertical Inside Bend  
Formed Only

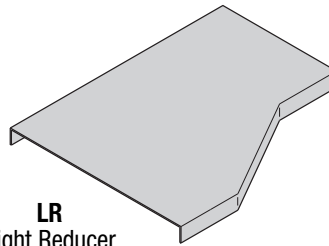

**LR**  
Right Reducer  
Mitered Only

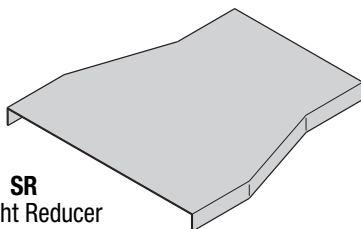

**SR**  
Straight Reducer  
Mitered Only

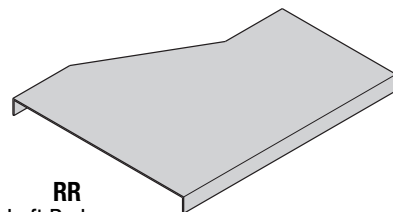

**RR**  
Left Reducer  
Mitered Only

**A full range of covers are available for fittings.**

**Solid flanged covers** should be used when maximum enclosure of the cable is desired and no accumulation of heat is expected.

**Flanged covers** have a 15mm flange. Cover clamps are not included with the cover and must be ordered separately.

## Fitting Covers

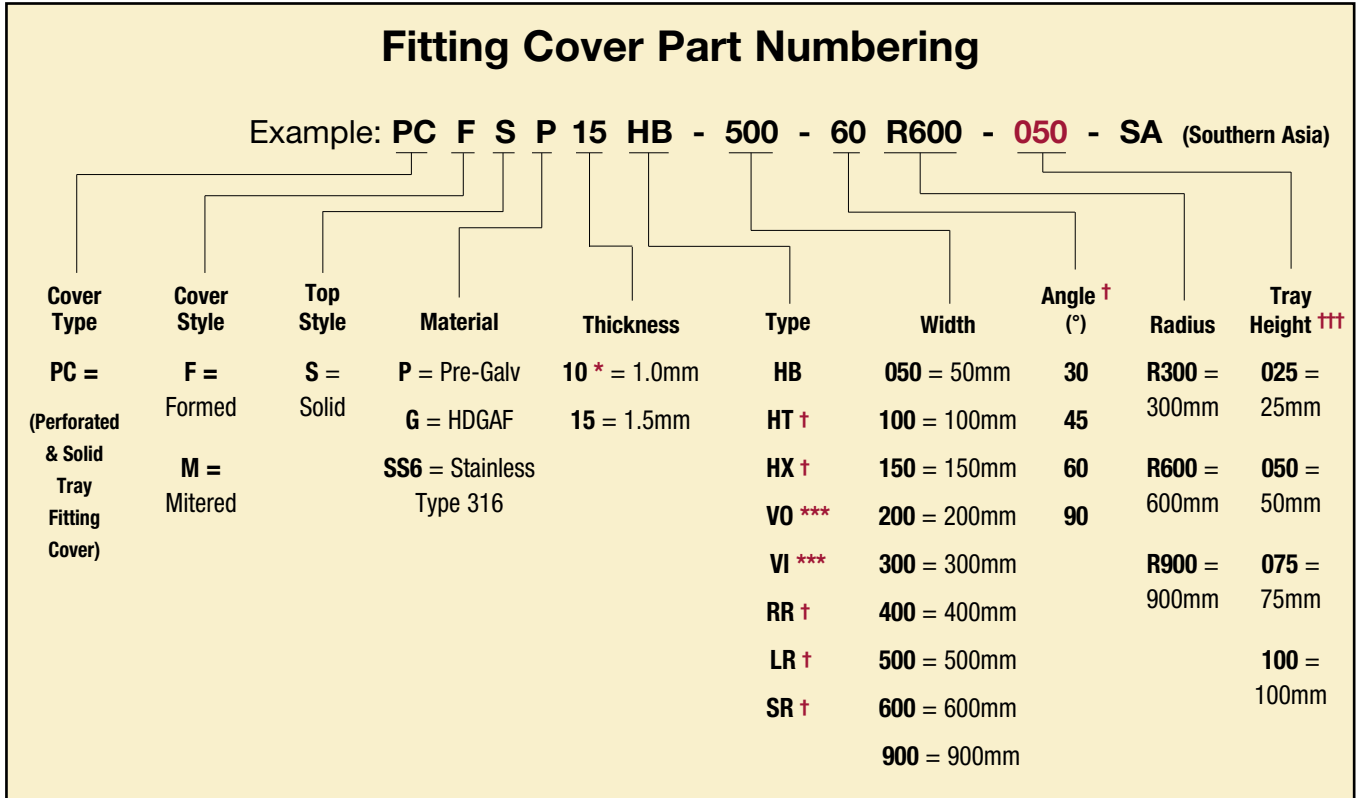

\* 1.0mm thickness is only available in widths up to and including 300 (300mm).

† No angle designation required on these fitting covers.

\*\*\* Not available as a mitered cover

††† Required on VO part numbers only.

# Cable Cleats

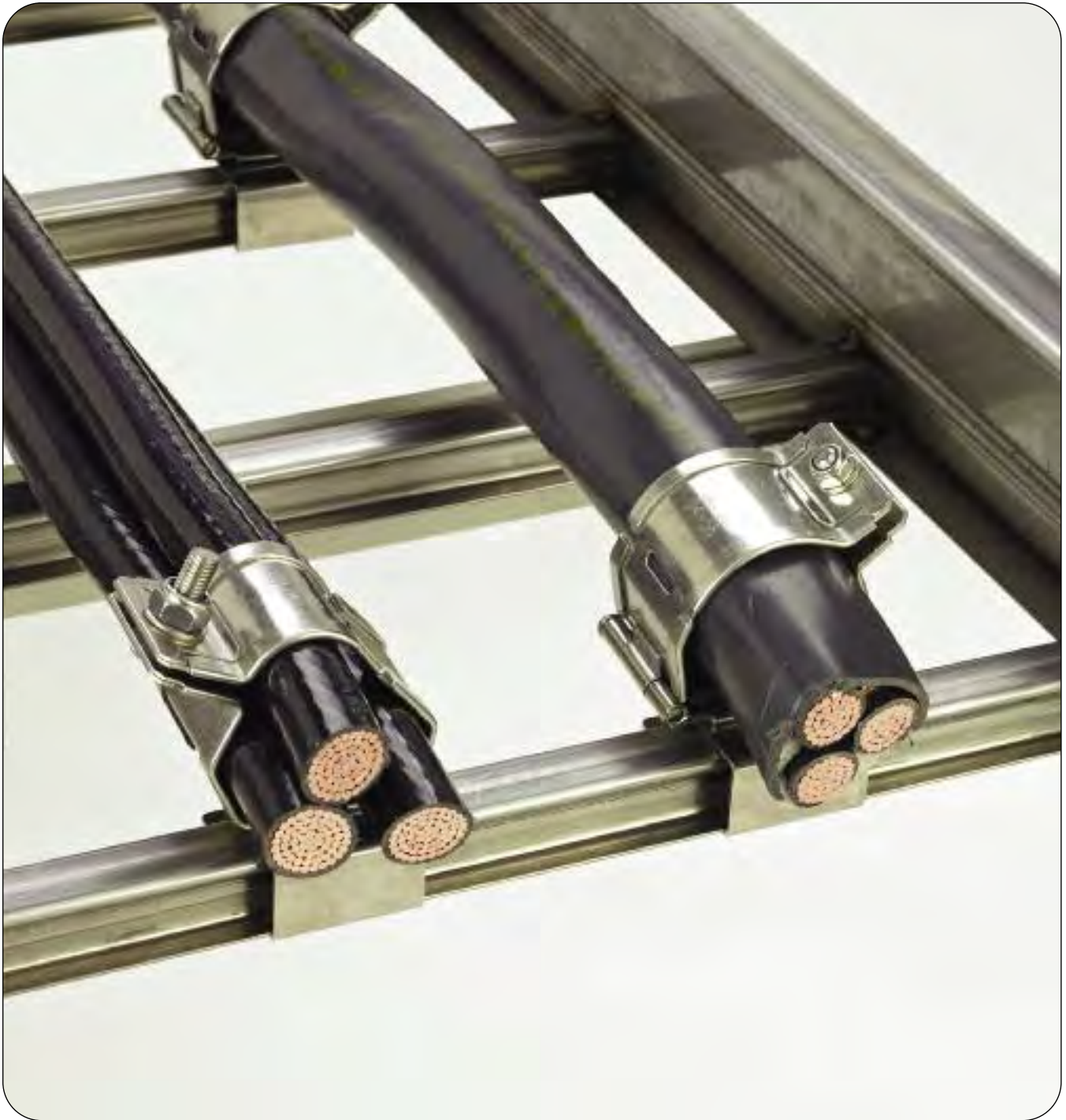

Cable Cleats

## Trefoil Cable Cleat with LSF Pad

1. Recommended for installations where the highest levels of short circuit withstand are required.
2. Short circuit current tested in accordance with BS EN 50368:2003 standard.
3. Available for single and trefoil cable applications.
4. LSF-pad incorporates an integral low smoke, low fume, zero halogen pad.
5. Hardware to attach cleat to rung is included with cleat.

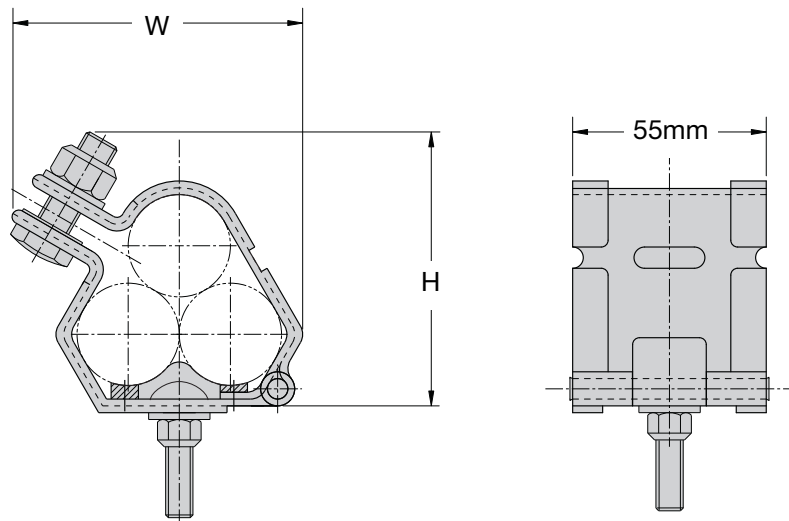

BS EN 50368:2003 (Cable Cleats for Electric Installations) Classification	
Cleat Type	Composite
Resistance to Electromechanical Force	130 kA peak / 50 kA RMS 600 mm spacing
Lateral Load Test	3.439 kg average
Axial Load Test	Pass
Operating Temperature Range	-40°C to +60°C
Impact Resistance	Very Heavy
Needle Flame Test	30 seconds

Technical Specifications	
Frame	50mm x 2mm Marine grade, Non-magnetic 316L
Closure Hardware	Captive 316 Stainless Steel M8 or M10 (M12 available) bolt and nylon-lock nut (Optional Hex Flange Lock Nut available)
Integral Pad	Low Smoke, Low Fume, Zero Halogen
Tools Required	Impact Wrench
Mounting Bolt	Provided with Cable Cleat

Part No.	Cable Range (mm)		Dimensions (mm)	
	Min. Dia.	Max. Dia.	H	W
9SS6-CCT1323	13	22	74	66
9SS6-CCT2125	21	25	77	70
9SS6-CCT2329	23	29	81	78
9SS6-CCT2531	25	31	84	81
9SS6-CCT2733	27	33	86	83
9SS6-CCT2935	29	35	90	89
9SS6-CCT3238	32	38	94	95
9SS6-CCT3541	35	41.5	98	100
9SS6-CCT3844	38	44.5	101	104
9SS6-CCT4248	42	48	105	111
9SS6-CCT4551	45	51	109	117
9SS6-CCT4753	47	53	111	120
9SS6-CCT4955	49	55	114	124
9SS6-CCT5157	51	57	116	127
9SS6-CCT5359	53	59	119	133
9SS6-CCT5561	55	61	127	137
9SS6-CCT5763	57	63	126	140
9SS6-CCT5965	59	65	128	144

Part No.	Cable Range (mm)		Dimensions (mm)	
	Min. Dia.	Max. Dia.	H	W
9SS6-CCT6167	61	67	132	147
9SS6-CCT6369	63	69	136	150
9SS6-CCT6571	65	71	140	153
9SS6-CCT6773	67	73	143	156
9SS6-CCT6975	69	75	147	160
9SS6-CCT7177	71	77	151	163
9SS6-CCT7379	73	79	154	166
9SS6-CCT7581	75	81	158	169
9SS6-CCT7783	77	83	161	173
9SS6-CCT7985	79	85	164	176
9SS6-CCT8187	81	87	169	179
9SS6-CCT8389	83	89	173	182
9SS6-CCT8896	88	96	181	192
9SS6-CCT96103	96	103	190	201
9SS6-CCT103111	103	111	199	204
9SS6-CCT111119	111	119	208	213
9SS6-CCT119128	119	128	217	221

All dimensions are in millimeters unless otherwise specified.

# Cable Cleats

## Single Cable Cleat with LSF Pad

1. Recommended for installations where the highest levels of short circuit withstand are required.
2. Short circuit current tested in accordance with BS EN 50368:2003 standard.
3. Available for single and trefoil cable applications.
4. LSF-pad incorporates an integral low smoke, low fume, zero halogen pad.
5. Hardware to attach cleat to rung is included with cleat.

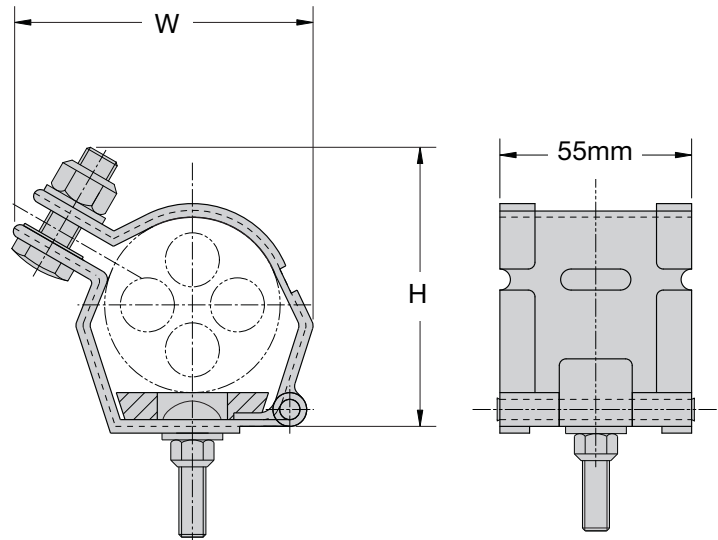
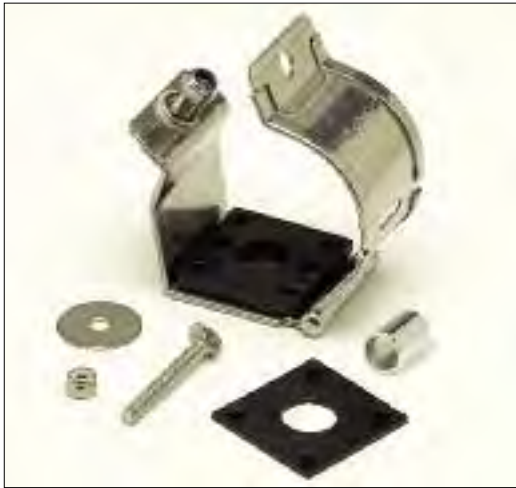

BS EN 50368:2003 (Cable Cleats for Electric Installations) Classification	
Cleat Type	Composite
Resistance to Electromechanical Force	130 kA peak / 50 kA RMS 600 mm spacing
Lateral Load Test	3.439 kg average
Axial Load Test	Pass
Operating Temperature Range	-40°C to +60°C
Impact Resistance	Very Heavy
Needle Flame Test	30 seconds

Technical Specifications	
Frame	50mm x 2mm Marine grade, Non-magnetic 316L
Closure Hardware	Captive 316 Stainless Steel M8 or M10 (M12 available) bolt and nylon-lock nut (Optional Hex Flange Lock Nut available)
Integral Pad	Low Smoke, Low Fume, Zero Halogen
Tools Required	Impact Wrench
Mounting Bolt	Provided with Cable Cleat

Part No.	Cable Range (mm)		Dimensions (mm)	
	Min. Dia.	Max. Dia.	H	W
9SS6-CCS2832	28	32	61	55
9SS6-CCS3034	30	34	63	57
9SS6-CCS3236	32	36	65	59
9SS6-CCS3438	34	38	67	61
9SS6-CCS3640	36	40	69	63
9SS6-CCS3842	38	42	71	65
9SS6-CCS4044	40	44	73	67
9SS6-CCS4246	42	46	75	69
9SS6-CCS4448	44	48	77	71
9SS6-CCS4650	46	50	79	73
9SS6-CCS4852	48	52	81	75
9SS6-CCS5054	50	54	83	77
9SS6-CCS5256	52	56	85	79
9SS6-CCS5458	54	58	87	81
9SS6-CCS5660	56	60	89	83
9SS6-CCS5862	58	62	91	85
9SS6-CCS6064	60	64	93	87
9SS6-CCS6266	62	66	95	89

Part No.	Cable Range (mm)		Dimensions (mm)	
	Min. Dia.	Max. Dia.	H	W
9SS6-CCS6468	64	68	97	91
9SS6-CCS6670	66	70	99	93
9SS6-CCS6872	68	72	101	95
9SS6-CCS7074	70	74	103	97
9SS6-CCS7276	72	76	105	99
9SS6-CCS7478	74	78	107	101
9SS6-CCS7680	76	80	109	103
9SS6-CCS7682	76	82	111	105
9SS6-CCS8084	80	84	113	107
9SS6-CCS8286	82	86	115	109
9SS6-CCS8488	84	88	117	111
9SS6-CCS8690	86	90	119	113
9SS6-CCS9094	90	94	121	115
9SS6-CCS94106	94	106	123	117
9SS6-CCS94118	94	118	125	119
9SS6-CCS100112	100	112	127	121
9SS6-CCS106118	106	118	129	123
9SS6-CCS138150	138	150	170	179

All dimensions are in millimeters unless otherwise specified.

## Step 1: Know Your Cables

- What type of cable is being used?
  - Single or Multi-conductor
- What is the outside diameter of the cable(s)?
- What is the cable arrangement (single conductor cables only)?
  - Flat or Trefoil
- If a ground wire will be installed within the cleat, you will need the ground wire outside diameter.

## Step 2: Know Your System

- What is the available short circuit current (RMS or  $i_p$  (peak))?
- What type of B-Line cable ladder is installed?

## Step 3: Select Your Cable Cleats

- See Pages 106 & 107

## Step 4: Determine Cleat Spacing for Installation

Your cable diameter is equal to the spacing between conductor centers shown below. Find your cable diameter at the top of the table and look down at the column below it. Find the value equal to or greater than the available short circuit for your system.

Single Conductor Short Circuit Withstand Table													
Max. Cable Cleat Spacing (A)		Spacing Between Conductor Centers (mm)											
		23	25	27	29	31	33	35	37	39	41	43	45
mm	In.	$i_p$ peak (kA)											
225	9	179	187	194	203	209	216	220	229	234	240	246	250
300	12	155	163	168	174	181	187	192	198	203	209	214	215
450	18	128	133	137	144	148	152	157	161	165	170	174	178
600	24	110	115	119	124	128	132	135	139	143	148	150	153
675	27	104	108	113	117	121	124	128	132	135	139	143	147
900	36	89	93	97	102	104	108	110	115	117	121	124	127

Cable Cleats

All dimensions are in millimeters unless otherwise specified.

# Cable Cleats

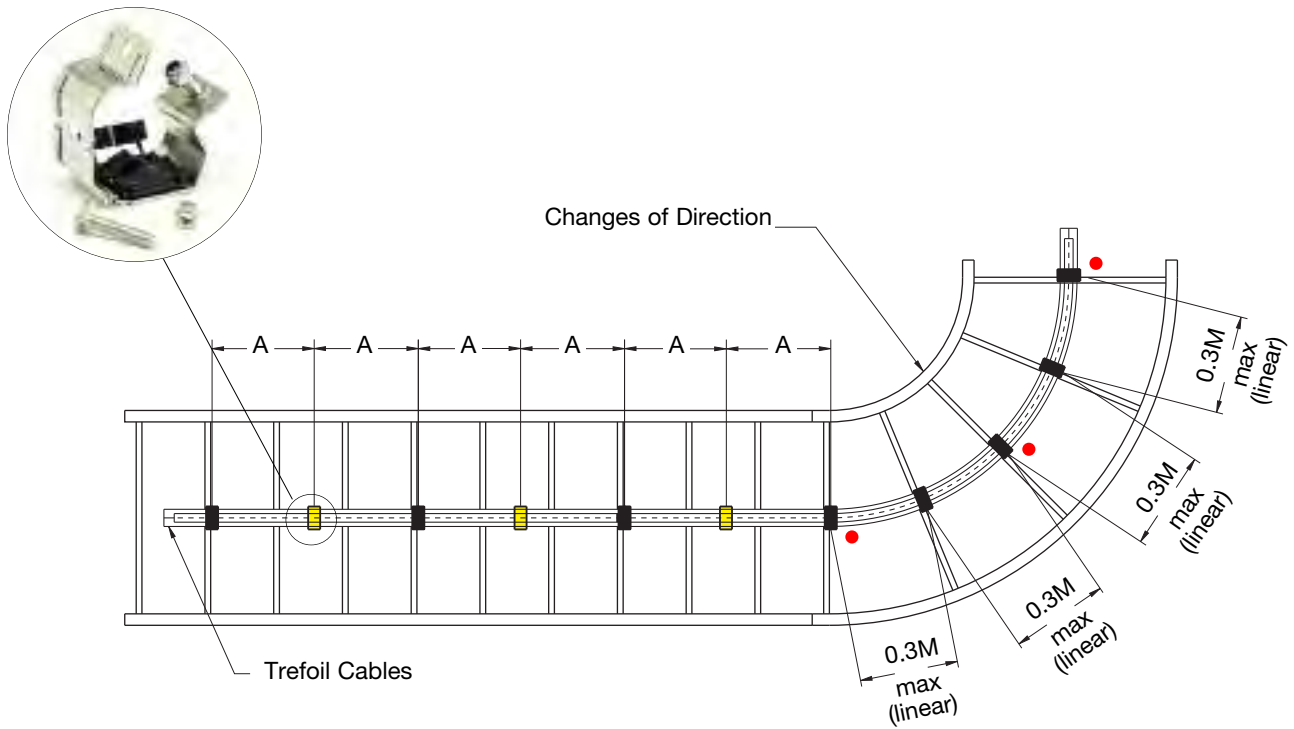

## IMPORTANT: Recommended Installation Procedures

It is important that the cleats are installed properly to secure your cables:

- It is not necessary for every cleat to be attached to the ladder. Every other cleat (■) must be attached to the ladder system to mount cable in ladder. Unattached cleats (□) provide additional restraint to keep cables bundled.
- The bend radius should be 8 to 12 times the cable diameter.
- Cable cleats should always be installed at the beginning, middle and end of a bend (●), and at no time should the distance between cleats on a bend be more than 0.3M center to center.



# Strut Systems

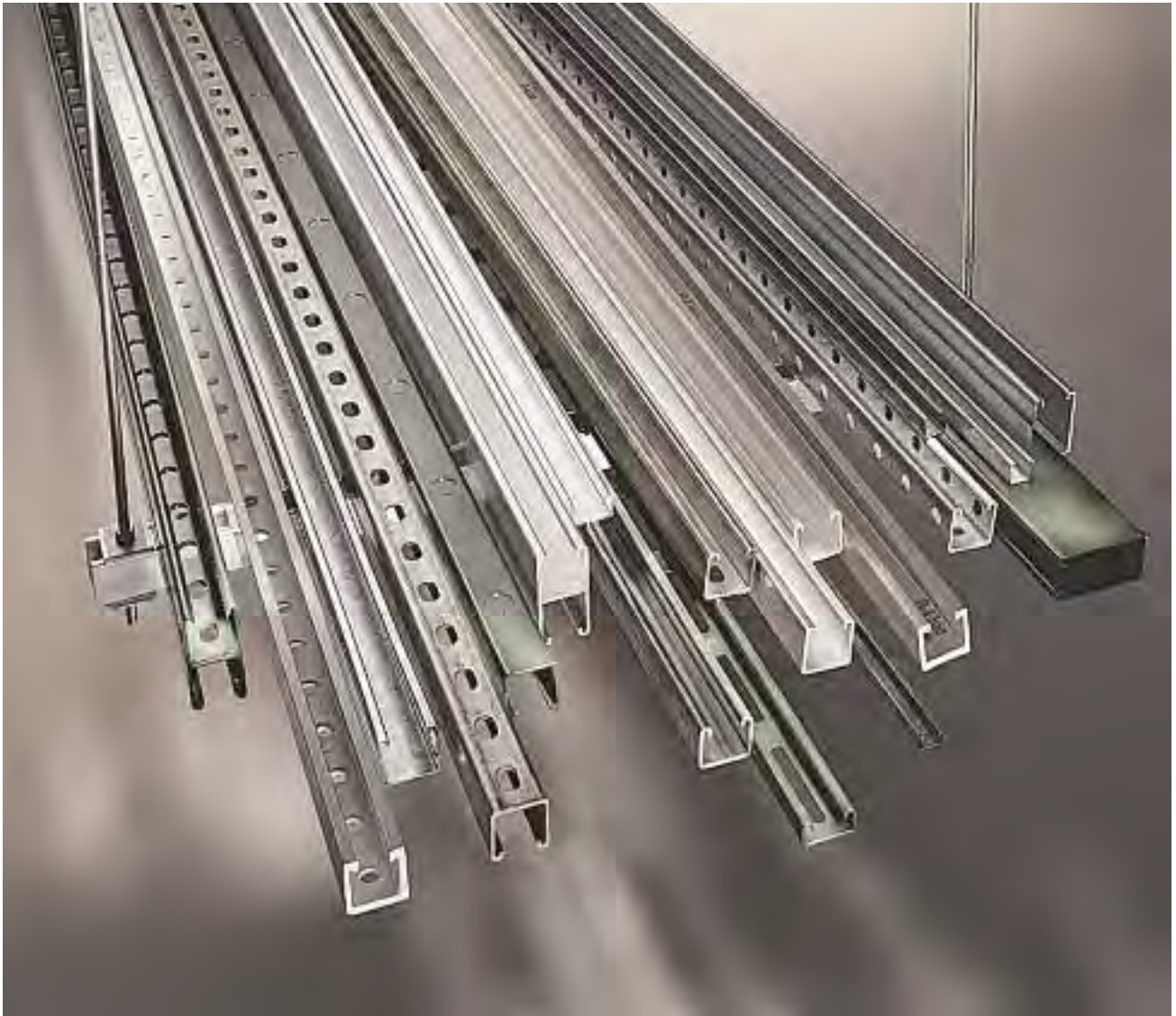

Bolted Framing

B-Line strut support systems are designed with many time-saving features. They are fully adjustable and reusable, with a complete line of channels, fittings and accessories for multi-purpose applications.

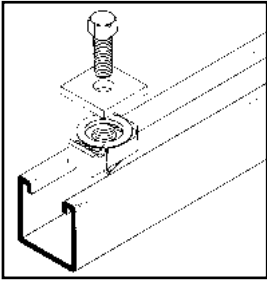

## No Welding - No Drilling - Multiple Applications

- Installs quickly
- No special tools required
- Use wrench and hacksaws
- Can be taken apart and re-used
- Provides the strength of a welded system
- Saves time by eliminating welding and drilling

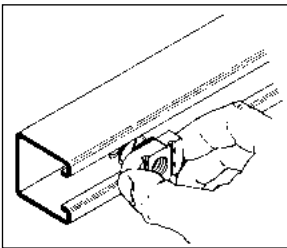

1. Channel nut may be inserted anywhere along continuous slot. Designed for easy insertion and self-alignment.

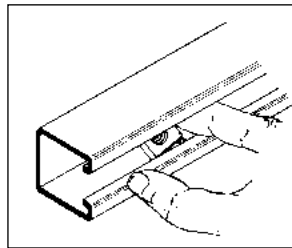

2. A 90° turn aligns channel nut grooves with inturned lips of the channel.

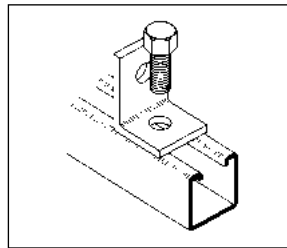

3. Position fitting over channel nut and insert bolt to start any connection.

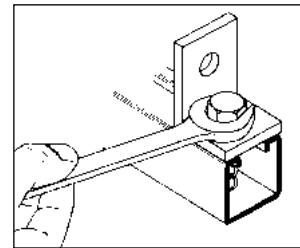

4. With the twist of a wrench, channel nut locks its teeth firmly against inturned lips.

B-Line strut system provides an economical solution for electrical, mechanical and industrial supports with an unlimited variety of applications in the construction industry.

### Electrical Applications

- Lighting Fixture Supports
- Raceway Systems
- Trapeze Hangers
- Pipe & Conduit Supports
- Cable Tray Supports
- Beam Adjustments

### Mechanical Applications

- Piping Racks
- Tunnel Pipe Stanchions
- Concrete Inserts
- Beam Attachments
- Pipe Risers

### Industrial Applications

- Racks and Shelving
- Partitions
- Production Line Supports
- Trolley Systems
- Wall Framing

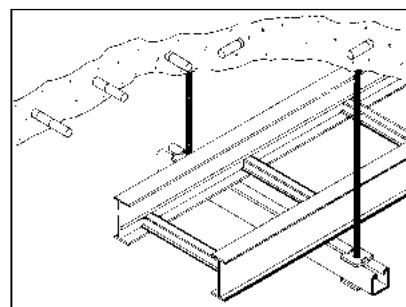
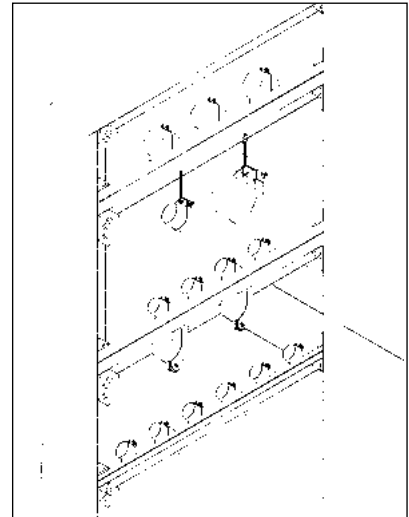
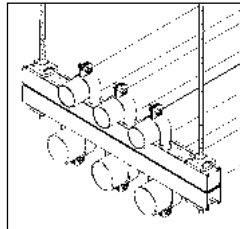

# Strut Systems - Technical Data

## MATERIALS

### Carbon Steel

Channels made from high-quality carbon steel are continuously roll formed to precise dimensions. By cold working the steel mechanical properties are increased, allowing lightweight structures to carry the required load. Corrosion resistance of carbon steel varies widely with coating and alloy. See "Finishes" for more detailed information.

### Stainless Steel

Stainless steel channel is available in AISI Type 316 material. Type 316 is non-magnetic and belongs to the austenitic stainless steels group, based on alloy content and crystallographic structure. Like carbon steel, stainless steel exhibits increased strength when cold worked by roll-forming.

Several conditions make the use of stainless steel ideal. These include reducing long term maintenance costs, high ambient temperatures, appearance, and stable structural properties such as yield strength, and high creep strength.

Type 316 resists most organic chemicals, dye stuffs and a wide variety of inorganic chemicals at elevated or cryogenic temperatures. Type 316 contains nickel and molybdenum to give it better corrosion resistance in chloride and sulfuric acid environments. More specific information concerning Type 316 is available from B-Line.

## FINISHES

### Zinc Coatings

Zinc protects steel in two ways. First it protects the steel as a coating and second as a sacrificial anode to repair bare areas such as cut edges, scratches, and gouges. The corrosion protection of zinc is directly related to its thickness and the environment. This means a 5µm coating will last twice as long as a 2.5µm coating in the same environment.

Galvanizing also protects cut and drilled edges.



### Electrogalvanized Zinc

Electrogalvanized Zinc (also known as zinc plated or electroplated) is the process by which a coating of zinc is deposited on the steel by electrolysis from a bath of zinc salts.

A rating of Fe/ZN 5 also known as SC1, B-Line hardware standard, provides a minimum zinc coating thickness of 5µm.

When exposed to air and moisture, zinc forms a tough, adherent, protective film consisting of a mixture of zinc oxides, hydroxides, and carbonates. This film is in itself a barrier coating which slows subsequent corrosive attack on the zinc. This coating is usually recommended for indoor use in relatively dry areas, as it provides ninety-six hours protection in salt spray testing per AS 2331.3.1 / ASTM B117.

## Hot Dip Galvanized After Fabrication (Hot dip galvanized or batch hot dip galvanized)

Hot dip galvanized strut products are fabricated from steel and then completely immersed in a bath of molten zinc. A metallic bond occurs resulting in a zinc coating that completely coats all surfaces, including edges and welds.

Another advantage of this method is coating thickness. Strut products that are hot dip galvanized after fabrication have a minimum thickness of 460g/m<sup>2</sup> on each side, or a total 920g/m<sup>2</sup>, according to AS/NZS 4680 / ASTM A123.

The zinc thickness is controlled by the amount of time each part is immersed in the molten zinc bath as well as the speed at which it is removed. The term "double dipping" refers to parts too large to fit into the galvanizing kettle; therefore, must be dipped one end at a time. It does not refer to extra coating thickness.

The layer of zinc which bonds to steel provides a dual protection against corrosion. It protects first as an overall barrier coating. If this coating happens to be scratched or gouged, zinc's secondary defense is called upon to protect the steel by galvanic action.

Hot-Dip Galvanized After Fabrication is recommended for prolonged outdoor exposure and will usually protect steel for 20 years or more in most atmospheric environments and in many industrial environments. For best results, a zinc rich paint (available from B-Line) should be applied to field cuts. The zinc rich paint will provide immediate protection for these areas and eliminate the short time period for galvanic action to "heal" the damaged coating.

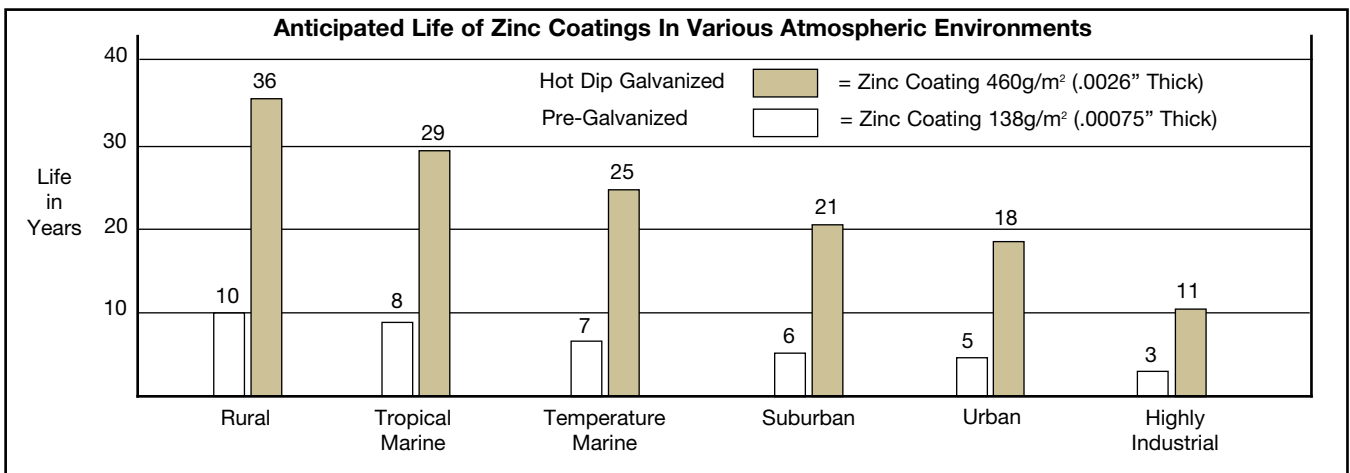

## WELDING

The welding procedures used in the fabrication of B-Line steel products are in accordance with recognized industry standards. To achieve the highest quality in our manufacturing processes, our welders are 3rd party certified.

### MIG Welding

MIG welded, more properly called gas metal arc welded (GMAW) combination channels and fittings, are produced when physical dimensions or certain combinations require a weld process other than automatic spot welding. The same quality control requirements are imposed on MIG welded and spot welded products.

### Quality Assurance

Our Quality Assurance Program has been developed and implemented for compliance with ISO 9001:2008. B-Line also complies with various industry standards and specifications.

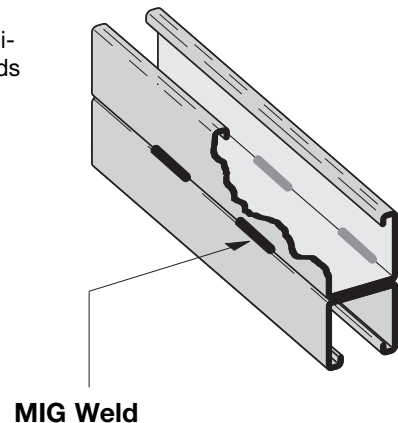

# Strut Systems - Technical Data

## CORROSION

All metal surfaces are affected by corrosion. Depending on the physical properties of the metal and the environment to which it is exposed, chemical or electromechanical corrosion may occur.

### Atmospheric Corrosion

Atmospheric corrosion occurs when metal is exposed to airborne liquids, solids or gases. Some sources of atmospheric corrosion are moisture, salt, dirt and sulphuric acid. This form of corrosion is typically more severe outdoors, especially near marine environments.

### Chemical Corrosion

Chemical corrosion takes place when metal comes in direct contact with a corrosive solution. Some factors which affect the severity of chemical corrosion include: chemical concentration level, duration of contact, frequency of washing, and operating temperature.

### Storage Corrosion

Wet storage stain (white rust) is caused by the entrapment of moisture between surfaces of closely packed and poorly ventilated material for an extended period. Wet storage stain is usually superficial, having no affect on the properties of the metal.

Light staining normally disappears with weathering. Medium to heavy build up should be removed in order to allow the formation of normal protective film. Proper handling and storage will help to assure stain-free material. If product arrives wet, it should be unpacked and dried before storage. Dry material should be stored in a well ventilated "low moisture" environment to avoid condensation formation. Outdoor storage is undesirable, and should be avoided whenever possible.

## Galvanic Corrosion

Galvanic corrosion occurs when two or more dissimilar metals are in contact in the presence of an electrolyte (ie. moisture). An electrolytic cell is created and the metals form an anode or a cathode depending on their relative position on the Galvanic Series Table. The anodic material will be the one to corrode. Anodic or cathodic characteristics of two dissimilar metals will depend on the type of each material. For example: If zinc and steel are in contact, the zinc acts as the anode and will corrode; the steel acts as the cathode, and will be protected. If steel and copper are in contact, the steel is now the anode and will corrode. The rate at which galvanic corrosion occurs depends on several factors:

1. The relative position on the Galvanic Series Table - the further apart materials are in the Galvanic Series Table, the greater the potential for corrosion of the anodic material.
2. The amount and concentration of electrolyte present - an indoor, dry environment will have little or no galvanic corrosion compared to a wet atmosphere.
3. The relative size of the materials - a small amount of anodic material in contact with a large cathodic material will result in greater corrosion. Likewise, a large anode in contact with a small cathode will decrease the rate of attack.

## GALVANIC SERIES IN SEA WATER

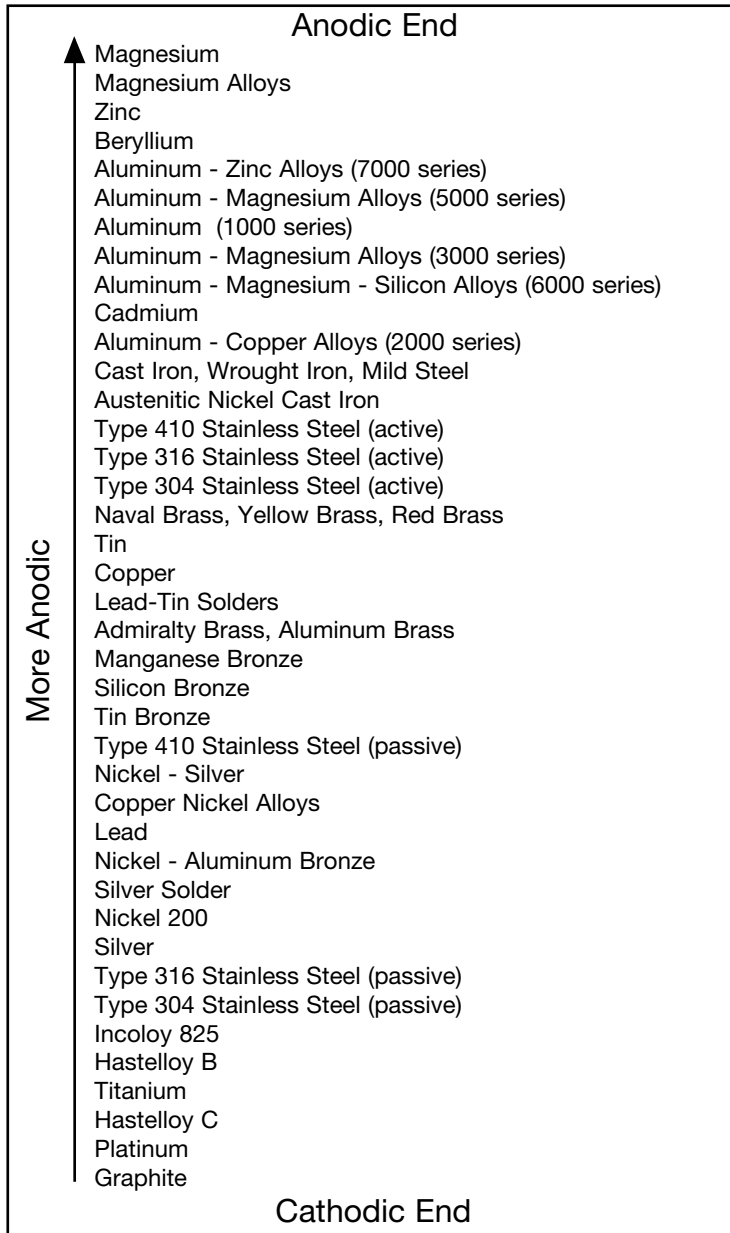

Metals in descending order of activity in the presence of an electrolyte.

## Design of Strut Systems

### Beams

Beams are usually defined as horizontal members which are subjected to vertical loads such as shelves, platforms or supports for pipes, conduits or cable ladders. The following is a brief overview of common beam configurations:

#### Simple Beam

An example of a simple beam is a length of channel placed across two cylinders. When a load is applied, the channel will support the load because of its stiffness. The cylinders serve to support the channel, but do not interfere with its natural tendency to flex or bend. Simple beam analysis is used almost universally for beam comparisons, even though it is seldom practical in field installations.

A cable ladder or conduit trapeze hanger closely resembles a simple beam.

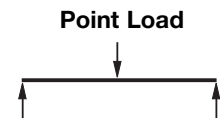

#### Fixed Beam

This type of fixed support restricts the movement of the ends of the channel when a load is applied. Because of this, the stiffness of the channel at the ends and center is employed to resist the load. The result is a load capability which is greater than that of an identical simple beam.

The fixed beam can be approximated by bolting or welding a length of channel to rigid supports.



#### Cantilever Beam

Cantilever beams are often viewed as variations of a fixed beam, but they have special characteristics of their own. One end of the channel is firmly attached to a rigid support while the other end remains completely free.

A shelf bracket is an example of a cantilever beam.



#### Continuous Beam

This beam configuration is commonly used in lighting installations. The continuous beam possesses traits of both the simple and fixed beams. When equal loads are applied to all spans simultaneously, the counter-balancing effect of the loads on both sides of a support restricts the movement of the channel at the support, similar to that of the fixed beam. The end spans behave substantially like simple beams.

Continuous beam installations can typically support 20% more load than a simple beam of the same span with approximately half the deflection.

Therefore, simple beam data should be used for a general comparison only. An example of this configuration is found in a long run of channel when installed across several supports to form a number of spans.

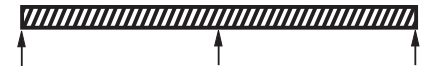

#### Deflection

Deflection, commonly referred to as "sag", is inherent in applying a load to a beam and cannot be avoided. Any and all beams will deflect when loaded. The amount of deflection will vary depending upon the material and the stiffness or moment of inertia. The deflection equations in this section show that increasing the stiffness can be increased by a variety of methods. Increasing the depth of the channel is the most direct method.

The material used affects deflection in a manner which is significantly different from the way in which it affects load capacity. The deflection under load is inversely proportional to a material property known as the "modulus of elasticity" designated by "E".

The modulus of elasticity is dependent upon the basic composition of the material and is not necessarily related to the material's strength.

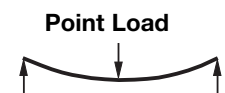

#### Safety Factor

The design loads given for strut beam loads are based on a simple beam condition using allowable stress of 172 MPa. This allowable stress results in a safety factor of 1.68. This is based upon a virgin steel minimum yield strength of 227 MPa cold worked during rolling to an average yield stress of 289 MPa.

Aluminum typically has an elastic modulus which is  $\frac{1}{3}$  that of steel even though they may have identical strength. As a result, the deflection of aluminum channel will be three times that of steel channel under equal loading. In areas where structures will be subject to general viewing, deflection can produce a displeasing effect. To the untrained eye, a sagging channel may appear to be a result of poor design or excessive loading. This is not usually the case. Many properly designed channel installations will show a noticeable deflection at their designed loads. In areas where cosmetics are not important, deflection should not be a factor. Designing an entire installation based on minimal deflection could result in an over designed structure. This translates into increased material and installation cost. Where cosmetics are important, it may be necessary to limit the deflection to an aesthetically pleasing amount. This "acceptable deflection" amount is typically given as a fraction of the span. **1/240 span** deflection is typically the limit where the amount of deflection appears negligible. For example, a beam span of 6000mm would be allowed 25mm (6000/240) of deflection at the mid point. A 3000mm span would only be allowed 12.5mm (3000/240) of deflection. The maximum load for the channel must be limited in order to remain under these deflection requirements. The allowable load resulting in 1/240 span deflection is posted in the beam load chart for each channel size.

For even more stringent deflection requirements, an allowable load is listed in the beam load charts which results in **1/360 span** deflection. This amount of deflection is sometimes used for beams in finished ceilings that are to be plastered.

# Strut Systems - Technical Data

## Twisting & Lateral Bracing

Loading of strut on long spans can cause torsional stress, resulting in the tendency of the strut to twist or bend laterally. This phenomenon reduces the allowable beam loads as shown in the beam loading charts. It is recommended that long spans be supported in a manner to prevent twisting (fixed ends), and that the channel have adequate lateral bracing. Many typical strut applications provide this support and bracing inherently. Piping, tubing, cable ladders, or conduits mounted to the strut with straps and clamps prevent twisting or lateral movement. If no such lateral support exists, contact the factory for loading recommendations.

## Columns

Columns are vertical members which carry loads in compression. One common example of a channel column is the vertical members of a storage rack.

In theory, a column will carry a load equal to its cross sectional area multiplied by the ultimate compressive stress of the material of which the column is made. In reality, there are many factors affecting the load capacity of a column, such as the tendency to buckle or twist laterally (torsional-flexural buckling), the type of connection at the top or bottom, the eccentricity of the load application, and material imperfections. Several of these failure modes have been considered in the allowable column load tables shown in the "Channel" section of this catalog.

B-Line strongly recommends that the engineer perform a detailed study of the many variable conditions before the selection process begins.

## Design Factors to be Considered

The loading capacity of channel depends primarily on the material, its cross-sectional design, and the beam or column loading configuration. It should be noted that if two lengths of channel have identical designs and configurations, the one made of the stronger base material will support a larger load. Therefore, any comparison of channel should begin by determining whether the materials are approximately equal in strength.

The column loading chart for each channel lists the allowable load for each channel in compression. This load varies depending on the support condition or "K-factor".

Several "K-factors" are listed, which correspond to the following support conditions:

K = .8 pinned top - fixed bottom

K = .65 fixed top - fixed bottom

K = 1.0 pinned top - pinned bottom

K = 1.2 free top - fixed bottom

There are a number of physical properties which are important to the complete design of a channel member; the "section modulus" designated as "Sx" or "Sy", "moment of inertia" designated by "Ix" or "Iy", and the "radius of gyration" which is given as "rx" or "ry".

Every structural material has its own maximum or ultimate stress, which is usually expressed in pascals. Any load which causes a member to fail is referred to as its "ultimate" load. In order to prevent channel from being accidentally loaded up to or beyond its ultimate load, a safety factor is included into the design. The ultimate load is divided by the safety factor to obtain the "recommended" or "allowable" working load.

When evaluating channel under various beam conditions, it is often more convenient to compare in terms of the ultimate or recommended "bending moment". Simple equations show the stress is directly proportional to the bending moment.

Therefore, comparing bending moments can save time in repeated calculations. The chart containing Formulas on Common Beam Loadings (following page) shows how to calculate the bending moment for various configurations and load conditions. It should be noted that the bending moment is usually not constant, but varies along the length of the span. However, the channel must be designed for a single point, which is the point of maximum bending moment.

For information regarding dynamic or seismic design, contact B-Line's Home Office.

## General Information

### Torque

The torque values given throughout the catalog are to be used as a guide only. The relationship between the applied torque or torque wrench reading and the actual tension created in the bolt may be substantially different. For example, a dry non-lubricated bolt with a heavy plating may rate 50% as efficient as a bolt which is lubricated with a mixture of heavy oil and graphite. Other important factors affecting torque-tension relationships include friction under the bolt head or nut, hole tolerances, and torque wrench tolerances. Accuracy of many commercial torque wrenches may vary as much as plus or minus 25%.

### Charts and Tables

Charts and tables in this section are compiled from information published by nationally recognized organizations and are intended for use as a guide only. B-Line recommends that users of this information determine the validity of such information as applied to their own application.

## RECOMMENDED STRUT SYSTEM SPECIFICATION

Brackets [ ] indicate alternative specifications which may be substituted by the project engineer.

### PART 1 - GENERAL

#### 1.01 WORK INCLUDED

- A. Continuous slot, bolted metal framing channels and all associated fittings and hardware.
- B. Trapeze type supports for cable ladder, conduit, pipe and other similar systems.
- C. Use of bolted metal framing as a surface metal raceway.

#### 1.02 REFERENCES

- A. AS/NZS 4680 / ASTM A123 - Specification for Zinc (hot-dip galvanized) Coatings on Products Fabricated from Rolled, Pressed, and Forged Steel Shapes, Plates, Bars and Strips.
- B. AS/NZS 1594 / ASTM A1011 - Specification for Steel, Sheet and Strip, Carbon, Hot-Rolled, Structural Quality.
- C. AS 1789 / ASTM B633 - Specification for Electrodeposited Coatings of Zinc on Iron and Steel.
- D. AS/NZS 1594 / ASTM A1018 - Standard Specification for Steel, Sheet and Strip, Heavy-Thickness Coils, Carbon, Hot-Rolled, Structural Quality.
- E. MFMA - Metal Framing Standards Publication, MFMA-4.

#### 1.03 QUALITY ASSURANCE

- A. Manufacturers : Firms regularly engaged in the manufacture of bolted metal framing of the types required, whose products have been in satisfactory use in similar service for not less than 5 years.
- B. For stainless steel items, the part number shall contain a material designator (EXAMPLE: B-Line B22SS6 for type 316 or B22SS4 for type 304), or a separate stamp shall be included to reference the type of material used.
- C. MFMA Compliance: comply with the latest revision of MFMA Standard Publication Number MFMA-4, "Metal Framing".
- D. NEC Compliance: Comply with the latest revision NFPA 70 - Article 352 "Surface Metal Raceways and Surface Nonmetallic Raceways".

#### 1.04 SUBMITTALS

- A. Submit drawings of strut and accessories including clamps, brackets, hanger rods and fittings.
- B. Submit manufacturer's product data on strut channels including, but not limited to, types, materials, finishes, gauge thickness and hole patterns. For each different strut cross section, submit cross sectional properties including Section Modulus (S<sub>x</sub>) and Moment of Inertia (I<sub>x</sub>).

#### 1.05 DELIVERY, STORAGE AND HANDLING

- A. Deliver strut systems and components carefully to avoid breakage, denting, and scoring finishes. Do not install damaged equipment.
- B. Store strut systems and components in original cartons and in clean dry space; protect from weather and construction traffic.

### PART 2 - PRODUCTS

#### 2.01 ACCEPTABLE MANUFACTURERS

- A. Manufacturer: Subject to compliance with these specifications, strut systems to be installed shall be as manufactured by B-Line, Inc. [or engineer approved equal.]

#### 2.02 STRUT CHANNELS AND COMPONENTS

- A. General: Strut shall be 41mm wide in varying heights and welded combinations as required to meet load capacities and designs indicated on the drawings.
- B. Material and Finish: Material and finish specifications for each strut type are as follows:
  1. Hot-Dip Galvanized Steel: Strut shall be made from structural quality steel meeting the minimum mechanical properties of AS/NZS 1594 / ASTM A1011 and shall be hot-dip galvanized after fabrication in accordance with AS/NZS 4680 / ASTM A123. Fittings shall be manufactured from steel meeting the minimum requirements of AS/NZS 1594 / ASTM A1018, and hot-dip galvanized after fabrication in accordance with AS/NZS 4680 / ASTM A123. All hardware shall be stainless steel Type 316 or hot-dip galvanized AS 1214 / ASTM A153.
  2. Stainless Steel: All strut, fittings and hardware shall be made of stainless steel Type 316 as indicated. Channels must be identified as required in previous section 1.03 Quality Assurance.

### PART 3 - EXECUTION

#### 3.01 INSTALLATION

- A. Install strut as indicated; in accordance with equipment manufacturer's recommendations, and with recognized industry practices.
- B. All nuts and bolts shall be tightened to the following values.

Bolt Size	Torque (Nm)
M6	12
M8	17
M10	36
M12	62

# Strut Systems - Technical Data

DESIGN LOAD DATA (For typical channel-fitting connections when USED IN PAIRS).

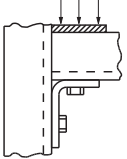
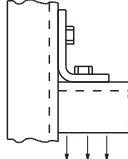
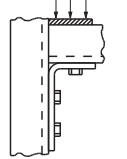
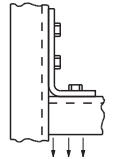
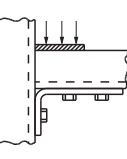
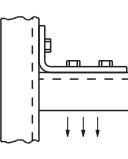
90° Fittings						
Channel Thickness						
	kN	kN	kN	kN	kN	kN
2.6mm	6.67	4.45	8.90	6.67	6.67	4.45

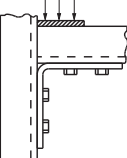
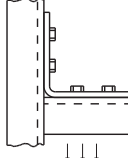
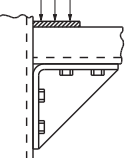
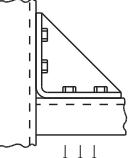
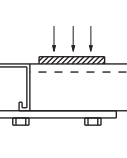
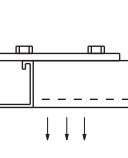
90° Fittings				Flat Fittings		
Channel Thickness						
	kN	kN	kN	kN	kN	kN
2.6mm	11.12	8.90	13.34	11.12	4.45	4.45

Design load data includes a safety factor of 2.5 (safety factor = ratio of ultimate load to design load).

## Channel

B-Line channel is cold formed on our modern rolling mills from 2.6mm low carbon steel strips. A continuous slot with inturned lips provides the ability to make attachments at any point.

## Lengths & Tolerances

All channels excluding 'SH' style  
 ± 3.2mm on 3m and  
 ± 4.76mm on 6m

All 'SH' channels only  
 ± 6.35mm on 3m and  
 ± 12.70mm on 6m

Custom lengths are available upon request.

## Slots

B-Line slotted series of channels offer full flexibility. A pre-punched slot pattern eliminates the need for precise field measuring for hole locations.

## Materials & Finishes (Unless otherwise noted)

### Steel: Plain & Pre-galvanized

2.6mm thick

Finish Code	Finish	Specification
PLN	Plain	AS/NZS 1594 / ASTM A1011
HDG	Hot-Dipped Galvanized	AS/NZS 4680 / ASTM A123
SS6	Stainless Steel	Type 316

Note: A minimum order may apply on special material and finishes.



## Design Load (Steel & Stainless Steel)

The design loads given for strut beam loads are based on a simple beam condition using an allowable stress of 172 MPa. This allowable stress results in a safety factor of 1.68. This is based upon virgin steel minimum yield strength of 227 MPa cold worked during rolling to an average yield stress of 289 MPa. For aluminum channel loading multiple steel loading by a factor of 0.38.

## Welding

Weld spacing is maintained at 76mm on center. Through high quality control testing of welded channels and continuous monitoring of welding equipment, B-Line provides one of the most consistent combination channels available today.

## Metric

Unless noted, all metric dimensions are in millimeters.

## Channel Part Numbering

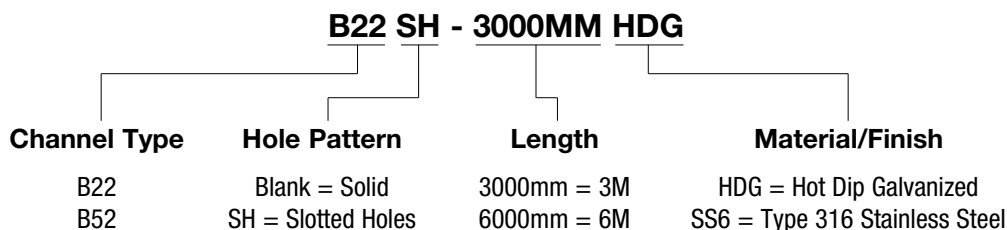

All dimensions are in millimeters unless otherwise specified.

# Strut Systems - Channels

## B22

- Thickness: 2.6mm
- Standard lengths: 3m & 6m
- Standard finishes: Hot-Dipped Galvanized, Stainless Steel Type 316
- Weight: 2.83kg/m

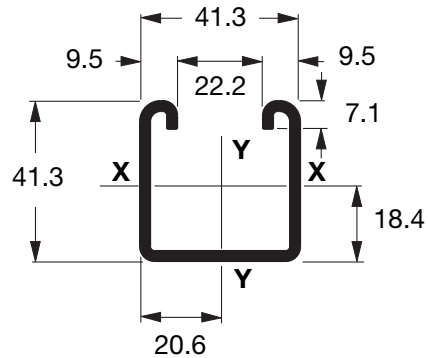
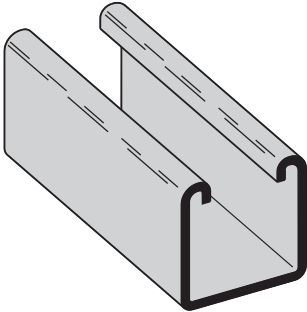

### Section Properties

Channel	Weight kg/m	Areas of Section cm <sup>2</sup>	X - X Axis			Y - Y Axis		
			Moment of Inertia (I) cm <sup>4</sup>	Section Modulus (S) cm <sup>3</sup>	Radius of Gyration (r) cm	Moment of Inertia (I) cm <sup>4</sup>	Section Modulus (S) cm <sup>3</sup>	Radius of Gyration (r) cm
B22	2.84	3.62	7.96	3.48	1.48	9.99	4.84	1.66
B22A	5.69	7.25	40.51	9.81	2.36	19.97	9.68	1.66

Calculations of section properties are based on metal thicknesses as determined by the AISI Cold-Formed Steel Design Manual.

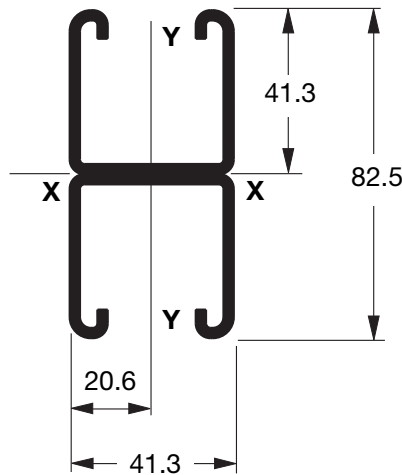
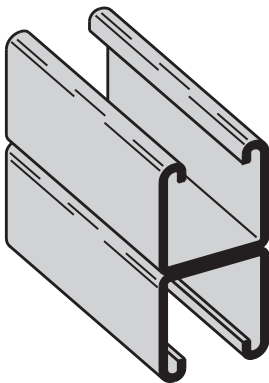

### B22SH SH Type Channel

- For beam loads use 90% of Channel Loading Chart
- Weight: 2.71kg/m

Bolted Framing

### B22A Wt. 5.65kg/m

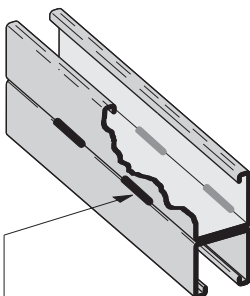

MIG Weld

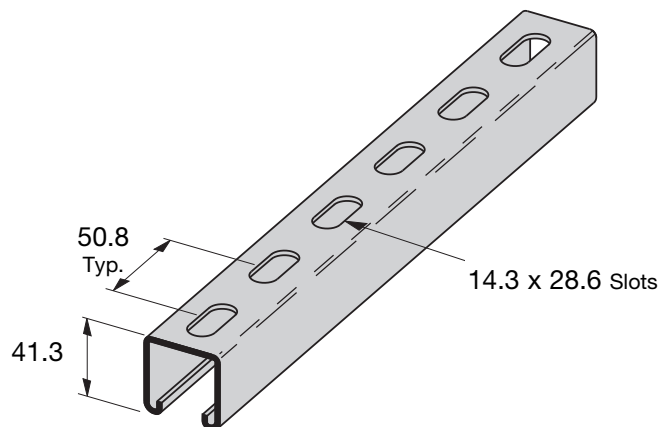

## Beam Loading

Beam Span mm	Channel Style	Uniform Load and Deflection		Uniform Load @ Deflection =	
		kN	mm	1/240 Span kN	1/360 Span N
305	<b>B22</b>	11.61	.35	11.61	11.61
	<b>B22A</b>	11.61*	.05	11.61*	11.61*
609	<b>B22</b>	7.57	1.42	7.57	7.57
	<b>B22A</b>	11.61*	.43	11.61*	11.61*
914	<b>B22</b>	5.05	3.20	5.05	4.00
	<b>B22A</b>	11.61*	1.45	11.61*	11.61*
1219	<b>B22</b>	3.78	5.69	3.37	2.24
	<b>B22A</b>	10.70	3.17	10.70	10.70
1524	<b>B22</b>	3.03	8.91	2.16	1.44
	<b>B22A</b>	8.56	4.95	8.56	7.29
1829	<b>B22</b>	2.52	12.83	1.50	1.00
	<b>B22A</b>	7.13	7.14	7.13	5.06
2133	<b>B22</b>	2.16	17.45	1.10	0.73
	<b>B22A</b>	6.11	9.73	5.58	3.72
2438	<b>B22</b>	1.89	22.81	0.84	0.56
	<b>B22A</b>	5.35	12.70	4.27	2.85
2743	<b>B22</b>	1.68	28.85	0.67	0.44
	<b>B22A</b>	4.75	16.08	3.37	2.25
3048	<b>B22</b>	1.51	35.63	0.54	0.36
	<b>B22A</b>	4.28	19.86	2.73	1.82

Based on simple beam condition using an allowable design stress of 172 MPa in accordance with MFMA, with adequate lateral bracing. Actual yield point of cold rolled steel is 289 MPa. To determine concentrated load capacity at mid span, multiply uniform load by 0.5 and corresponding deflection by 0.8. \*Failure determined by weld shear.

## Column Loading

Unbraced Height mm	Channel Style	Max. Column Loading K = .80		Max. Column Loading (Loaded @ C.G.)		
		Loaded@ C.G. kN	Loaded@ Slot Face kN	K = .65 kN	K = 1.0 kN	K = 1.2 kN
305	<b>B22</b>	46.50	19.12	47.14	45.47	44.26
	<b>B22A</b>	96.19	31.14	96.42	95.81	95.34
609	<b>B22</b>	41.42	17.76	43.60	38.17	34.70
	<b>B22A</b>	94.14	30.68	95.07	92.61	90.73
914	<b>B22</b>	34.70	15.96	38.59	28.33	23.98
	<b>B22A</b>	90.73	29.93	92.81	87.27	83.04
1219	<b>B22</b>	27.55	13.87	32.92	20.99	16.86
	<b>B22A</b>	85.95	28.89	89.66	79.80	72.29
1524	<b>B22</b>	20.99	11.70	27.10	16.08	13.06
	<b>B22A</b>	79.80	23.75	85.60	70.20	58.45
1829	<b>B22</b>	16.86	10.07	21.66	13.06	10.59
	<b>B22A</b>	72.29	17.65	80.64	58.45	42.36
2133	<b>B22</b>	14.13	8.82	17.96	10.95	8.81
	<b>B22A</b>	63.41	13.47	74.78	44.82	31.23
2438	<b>B22</b>	16.58	7.83	15.37	9.34	7.43
	<b>B22A</b>	53.16	10.49	68.02	34.32	23.83
2743	<b>B22</b>	10.59	7.00	13.44	8.08	68.60**
	<b>B22A</b>	42.36	8.30	60.35	27.11	18.83
3048	<b>B22</b>	9.34	6.31	11.92	7.04**	5.46**
	<b>B22A</b>	34.32	6.72	51.78	21.96	15.25**

\*\*Where the slenderness ratio  $\frac{KL}{r}$  exceeds 200, and K = end fixity factor, L = actual length and r = radius of gyration.

All dimensions are in millimeters unless otherwise specified.

# Strut Systems - Channels

## B52

- Thickness: 2.6mm
- Standard lengths: 3m & 6m
- Standard finishes: Hot-Dipped Galvanized, Stainless Steel Type 316
- Weight: 1.89kg/m

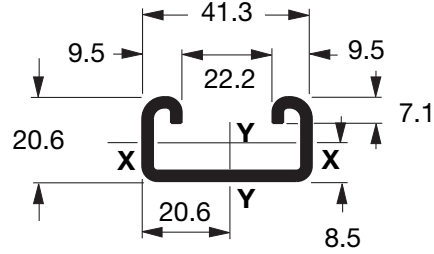
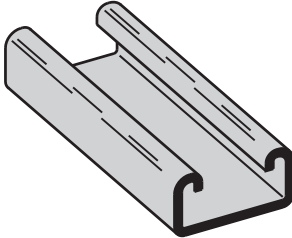

### Section Properties

Channel	Weight kg/m	Areas of Section cm <sup>2</sup>	X - X Axis			Y - Y Axis		
			Moment of Inertia (I) cm <sup>4</sup>	Section Modulus (S) cm <sup>3</sup>	Radius of Gyration (r) cm	Moment of Inertia (I) cm <sup>4</sup>	Section Modulus (S) cm <sup>3</sup>	Radius of Gyration (r) cm
<b>B52</b>	1.95	2.49	1.33	1.10	.73	5.84	2.83	1.53

Calculations of section properties are based on metal thicknesses as determined by the AISI Cold-Formed Steel Design Manual.

## B52SH SH Type Channel

- For beam loads use 90% of Channel Loading Chart
- Weight: 1.77kg/m

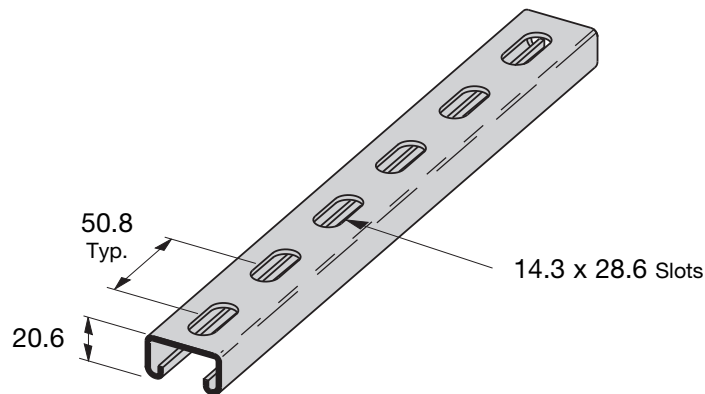

## Beam Loading

Beam Span mm	Channel Style	Uniform Load and Deflection		Uniform Load @ Deflection =	
		kN	mm	1/240 Span kN	1/360 Span kN
305	<b>B52</b>	4.80	.66	4.80	4.80
609	<b>B52</b>	2.40	2.69	2.25	1.50
914	<b>B52</b>	1.60	6.09	1.00	0.67
1219	<b>B52</b>	1.20	10.84	0.56	0.37
1524	<b>B52</b>	0.96	16.94	0.36	0.24
1829	<b>B52</b>	0.80	24.38	0.25	0.16
2133	<b>B52</b>	0.68	33.20	0.18	0.12
2438	<b>B52</b>	0.60	43.36	0.14	0.09
2743	<b>B52</b>	0.53	54.86	0.11	0.07
3048	<b>B52</b>	0.48	67.74	0.09	0.06

Based on simple beam condition using an allowable design stress of 172 MPa in accordance with MFMA, with adequate lateral bracing. Actual yield point of cold rolled steel is 289 MPa. To determine concentrated load capacity at mid span, multiply uniform load by 0.5 and corresponding deflection by 0.8. \*Failure determined by weld shear.

## Column Loading

Unbraced Height mm	Channel Style	Max. Column Loading K = .80		Max. Column Loading (Loaded @ C.G.)		
		Loaded@ C.G. kN	Loaded@ Slot Face kN	K = .65 kN	K = 1.0 kN	K = 1.2 kN
305	<b>B52</b>	37.39	14.06	38.00	36.50	35.54
609	<b>B52</b>	33.44	12.25	35.05	29.01	24.01
914	<b>B52</b>	24.01	9.57	29.59	16.08	11.17
1219	<b>B52</b>	14.13	6.94	21.28	9.05	6.28**
1524	<b>B52</b>	9.05	5.15	13.70	5.79**	4.02**
1829	<b>B52</b>	6.28**	3.96	9.51	4.02**	-
2133	<b>B52</b>	4.62**	3.13	6.99	2.95**	-
2438	<b>B52</b>	3.53**	2.53	5.35**	-	-
2743	<b>B52</b>	-	2.09	4.23**	-	-
3048	<b>B52</b>	-	1.75	3.42**	-	-

\*\*Where the slenderness ratio  $\frac{KL}{r}$  exceeds 200, and K = end fixity factor, L = actual length and r = radius of gyration.

# Strut Systems - Hardware

## Channel Nuts

B-Line channel nut is one of the main components of our bolted metal framing system. It is designed to provide essential gripping power and ease during installation. Channel nuts are press formed, machined and hardened from steel.

## Recommended Torque

Bolt Size	M6x1	M8 x1.25	M10 x 1.5	M12x1.75
Nm	12	17	36	62

## Materials & Finishes\*

Finish Code	Finish	Specification
ZN	Electro-Plated Zinc	AS 1897 / ASTM B633 SC1 Type III
HDG	Hot-Dipped Galvanized	AS 1214 / ASTM A153
SS6	Stainless Steel	Type 316

\*Unless otherwise noted.

Note: Channel nuts are not available in HDG.



## Metric

Unless noted, all metric dimensions are in millimeters.

Note: See below for resistance to slip and pull-out strength.

- Finish: ZN, SS6

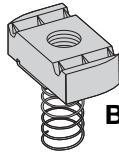

**BMS\_M**  
Series

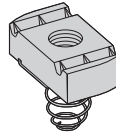

**BMS\_S**  
Series

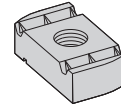

**BMS\_**  
Series

## Spring Nut

Part No.	Thread Size	Fits Channel Sizes	Nut Thickness mm	Wt./C kg
<b>BMS-6M</b>	M6 x 1	B22	6.3	3.13
<b>BMS-6S</b>	M6 x 1	B52	6.3	3.13
<b>BMS-6</b>	M6 x 1	B22 & B52	6.3	3.13
<b>BMS-8M</b>	M8 x 1.25	B22	6.3	3.04
<b>BMS-8S</b>	M8 x 1.25	B52	6.3	3.04
<b>BMS-8</b>	M8 x 1.25	B22 & B52	6.3	3.04
<b>BMS-10M</b>	M10 x 1.5	B22	9.5	4.35
<b>BMS-10S</b>	M10 x 1.5	B52	9.5	4.35
<b>BMS-10</b>	M10 x 1.5	B22 & B52	9.5	4.35
<b>BMS-12M</b>	M12 x 1.75	B22	9.5	4.17
<b>BMS-12S</b>	M12 x 1.75	B52	9.5	4.17
<b>BMS-12</b>	M12 x 1.75	B22 & B52	9.5	4.17

## Resistance To Slip

- With Safety Factor of 3

Thread Size	Nut Part Numbers	Resistance to Slip	
		2.6mm Channel ZN kN	SS6 kN
M6 x 1	<b>BMS-6M, BMS-6S, BMS-6, NWM6</b>	1.33	0.65
M8 x 1.25	<b>BMS-8M, BMS-8S, BMS-8, NWM8</b>	2.00	1.00
M10 x 1.50	<b>BMS-10M, BMS-10S, BMS-10, NWM10</b>	3.56	1.78
M12 x 1.75	<b>BMS-12M, BMS-12S, BMS-12, NWM12</b>	6.67	3.33

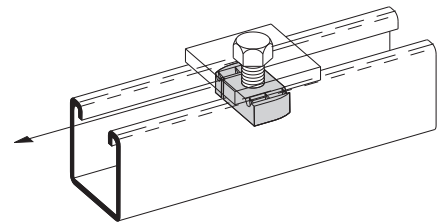

**Resistance to Slip of Channel Nut**

## Pull-Out Strength

- With Safety Factor of 3

Thread Size	Nut Part Numbers	Pull-Out Strength
		2.6mm Channel kN
M6 x 1	<b>BMS-6M, BMS-6S, BMS-6, NWM6</b>	2.00
M8 x 1.25	<b>BMS-8M, BMS-8S, BMS-8, NWM8</b>	3.33
M10 x 1.50	<b>BMS-10M, BMS-10S, BMS-10, NWM10</b>	4.89
M12 x 1.75	<b>BMS-12M, BMS-12S, BMS-12, NWM12</b>	6.67

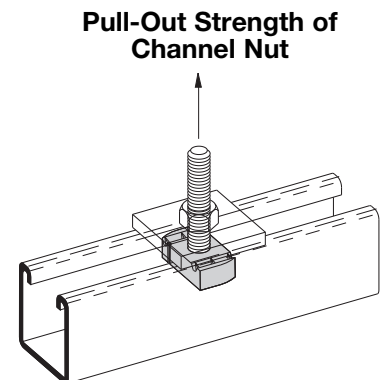

**Pull-Out Strength of Channel Nut**

All dimensions are in millimeters unless otherwise specified.

## Combo Nut Washer

- Finish: Zinc Plated (ZN) or 316 Stainless Steel (SS6) - add SS6 to part number
- To lock combo nut washer in place a hex nut (sold separately) is required

Note: See page 18 for resistance to slip & pull-out strength.

Patent Number  
7,604,444

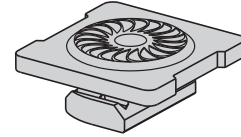

Part No.	Thread Size	Fits Channel Sizes	Nut Thickness mm	Wt./C kg
NWM6	M6	All Channel Sizes	6.3	7.50
NWM8	M8	All Channel Sizes	6.3	7.00
NWM10	M10	All Channel Sizes	9.5	8.57
NWM12	M12	All Channel Sizes	9.5	8.00

## Buzznut™

- Can be installed at any desired position on the ATR, eliminating the need to thread hex nuts up along ATR.
- Loading Safety Factor of 3.
- Torque: 8N•m
- Available in Zinc Plated (ZN) or 316 Stainless Steel (SS6).

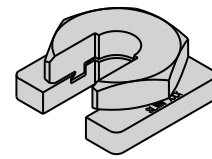

Part No.	Thread Size	Loading kN	Wt./C kg
SLWNM6	M6	0.90	6.4
SLWNM8	M8	1.70	7.4
SLWNM10	M10	2.60	7.8
SLWNM12	M12	3.70	8.6

## SLN Slip-On Lock Nut

- Safety Factor of 3
- Standard finish: Zinc Plated (ZN) or 316 Stainless Steel (SS6)

Part No.	Thread Size	Wt./C kg
SLNM6	M6	5.8
SLNM8	M8	6.8
SLNM10	M10	7.2
SLNM12	M12	8.0



## B217P Plastic Snap Closure Strip For All 41.3mm Wide Channels

- Standard finishes: Gray (GRY) Plastic
- Standard length: 3m
- Wt./30.5m: 4.2kg

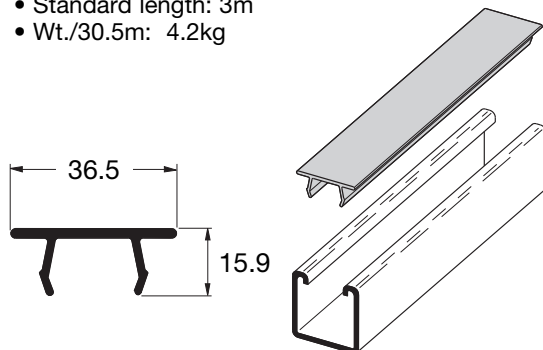

## B825 Series Plastic End Caps

- Material: Polyurethane
- Available in colors: Gray (GRY)

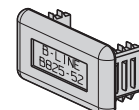
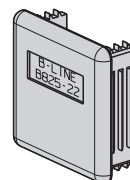

Part No.	Fits Channel Sizes	Wt./C kg
B825-22	B22	0.9
B825-52	B52	0.4

## HHCS

### Hex Head Cap Screws

- Standard finish: HDG, Stainless Steel Type 316

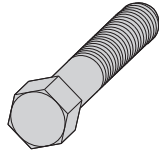

Part No.	Wt./C kg
M6x20 HHCS	0.63
M6x25 HHCS	0.77
M8x20 HHCS	1.04
M8x25 HHCS	1.27
M10x25 HHCS	1.90
M12x20 HHCS	3.48
M12x25 HHCS	3.81
M12x30 HHCS	4.17

## HN

### Hex Nuts

- Standard finish: HDG, Stainless Steel Type 316

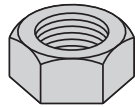

Part No.	Wt./C kg
M6 HN	0.32
M8 HN	0.45
M10 HN	0.68
M12 HN	1.63

## FW

### FLAT WASHERS

- Standard finish: HDG, Stainless Steel Type 316

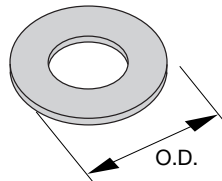

Part No.	O.D. Outside Dia. mm	Wt./C kg
FW M6	18.7	0.32
FW M8	22.2	0.63
FW M10	25.4	0.77
FW M12	34.9	1.77

## ATR

### All Threaded Rod

- Available in 3000mm lengths
- Safety Factor of 5 on recommended load
- Standard finish: HDG, Stainless Steel Type 316

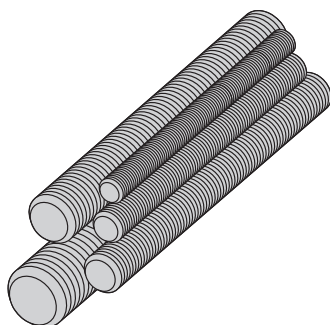

Part No. & Size	Threads Size	Recommended Load kN	Wt./30.5m kg
ATR M6	M6	1.32	6.1
ATR M8	M8	2.42	10.7
ATR M10	M10	3.66	15.3
ATR M12	M12	5.35	24.4

All dimensions are in millimeters unless otherwise specified.

# Strut Systems - Fittings

A selection of fittings and accessories are available to complete B-Line bolted strut system.

## Dimensions

The following dimensions apply to all fittings except as noted.

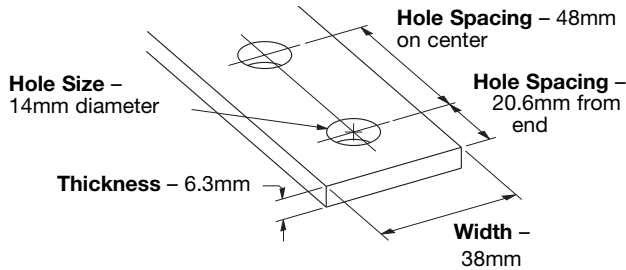

## Materials & Finishes (Unless otherwise noted)

Finish Code	Finish	Specification
PLN	Plain	AS/NZS 1594 / ASTM A1018
HDG	Hot-Dipped Galvanized	AS/NZS 4680 / ASTM A123
SS6	Stainless Steel	Type 316

Note: A minimum order may apply on special material and finishes.



## Load Data

The load data published includes safety factor of 2.5 when used with 2.6mm channel (safety factor = ratio of ultimate load to the design load).

Use M12 x 20 hex head cap screws and BMS-12 channel nuts for the rated results.

## Recommended Bolt Torque

Bolt Size	M6	M8	M10	M12
Nm	12	17	36	62

## Hardware

Nuts and bolts are not included with the fittings and must be ordered separately, unless noted.

## Metric

All dimensions are in millimeters unless noted otherwise.

## B200 Series Square Washer

- Standard finishes: HDG, SS6

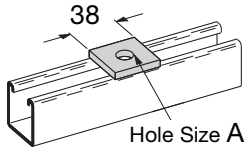

## B200-D Series No-Twist Square Washer

- Standard finishes: HDG, SS6

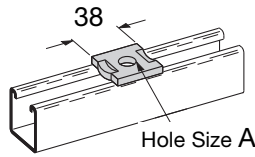

Part No.	A	Bolt Size	Wt./C kg
B201	11.1	M10	7.7
B202	14.2	M12	7.7
B201-D	11.1	M10	7.7
B202-D	14.2	M12	7.7

## B129 Two-Hole Splice Plate

- Standard finishes: HDG, SS6
- Wt./C: 16.8kg

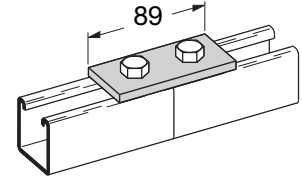

## B140 Three-Hole Corner Plate

- Standard finishes: HDG, SS6
- Wt./C: 25.4kg

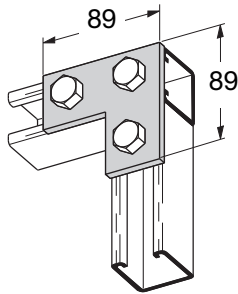

## B141 Three-Hole Splice Plate

- Standard finishes: HDG, SS6
- Wt./C: 24.9kg

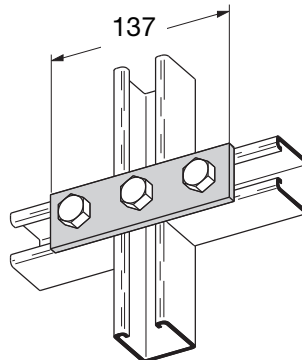

## B341 Four-Hole Splice Plate

- Standard finishes: HDG, SS6
- Wt./C: 34.5kg

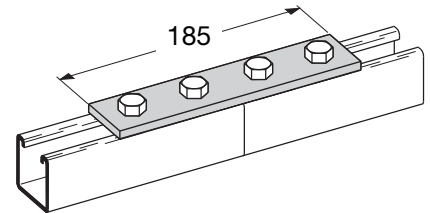

## B133 Four-Hole Tee Plate

- Standard finishes: HDG, SS6
- Wt./C: 34.0kg

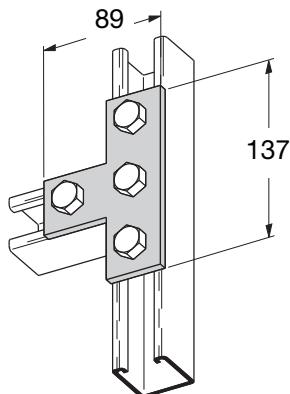

## B143 Four-Hole Corner Angle

- Standard finishes: HDG, SS6
- Wt./C: 34.0kg

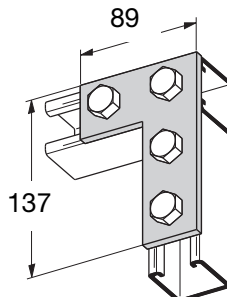

## B101 Two-Hole Corner Angle

- Standard finishes: HDG, SS6
- Wt./C: 16.8kg

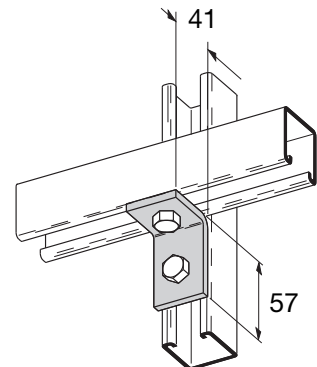

All dimensions are in millimeters unless otherwise specified.

# Strut Systems - Fittings

## B230 Two-Hole Corner Angle

- Standard finishes: HDG, SS6
- Wt./C: 16.8kg

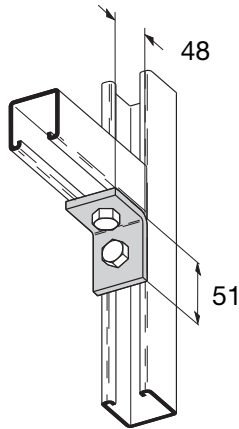

## B102 Three-Hole Corner Angle

- Standard finishes: HDG, SS6
- Wt./C: 25.4kg

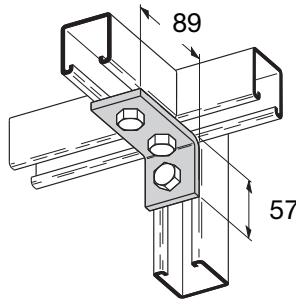

## B103 Three-Hole Corner Angle

- Standard finishes: HDG, SS6
- Wt./C: 25.4kg

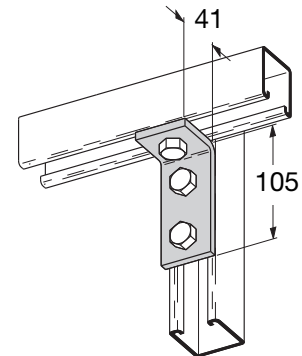

## B104 Four-Hole Corner Angle

- Standard finishes: HDG, SS6
- Wt./C: 35.4kg

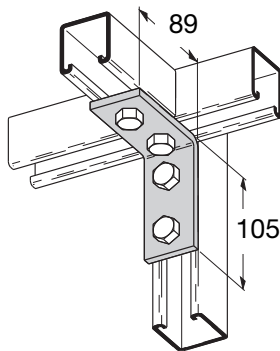

## B409 Single Channel Bracket

- Safety Factor of 2.5
- Standard finishes: HDG, SS6

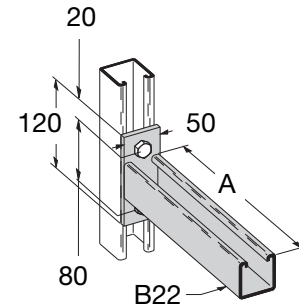

Part No.	A	Uniform Load kN	Wt./C kg
B409-300	300	4.27	105.2
B409-600	600	2.13	204.1

## B107 Five Hole U-Support

- Standard finishes: HDG, SS6
- Wt./C: 38.5kg

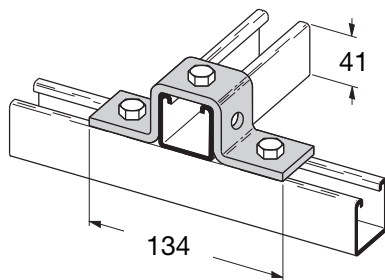

## B297 Double Channel Bracket

- Safety Factor of 2.5
- Standard finishes: HDG, SS6

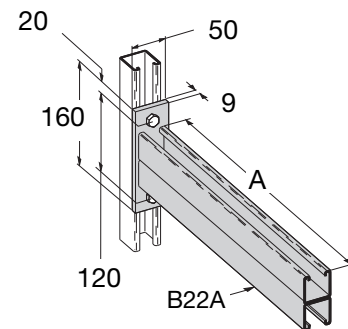

Part No.	A	Uniform Load kN	Wt./C kg
B297-750	750	2.95	471.7
B297-1000	1000	2.06	653.2

## B279FL Post Base For B22

- Standard finishes: HDG, SS6
- Wt./C: 104.3kg

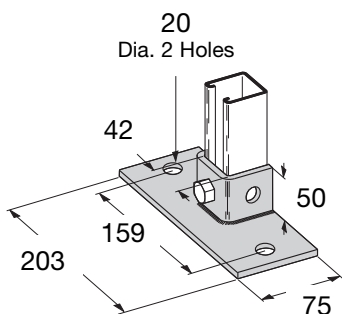

## B281AFL Post Base For B22A

- Standard finishes: HDG, SS6
- Wt./C: 113.4kg

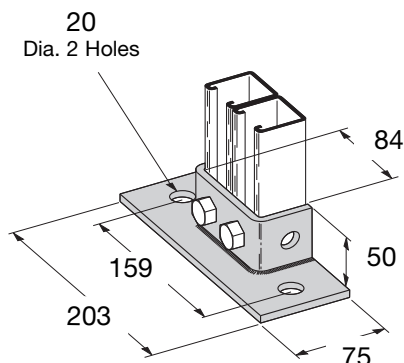

## B441-22 Beam Clamp (Sold in Pieces)

- Design Load 5.34kN when used in pairs
- Safety Factor of 5
- 19.0mm Max. Flange Thickness
- For use with 20.6mm to 41.3mm high channel
- Recommended Torque: 16.9N•m
- Other flange thickness variations are available, contact B-Line Engineering for sizes
- Standard finishes: HDG, SS6
- Wt./C: 39.4kg

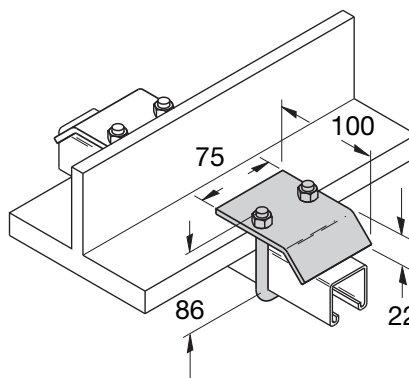

## B441-22A Beam Clamp (Sold in Pieces)

- Design Load 5.34kN when used in pairs
- Safety Factor of 5
- 19.0mm Max. Flange Thickness
- For use with 41.3mm to 82.5mm high channel
- Recommended Torque: 16.9N•m
- Other flange thickness variations are available, contact B-Line Engineering for sizes
- Standard finishes: HDG, SS6
- Wt./C: 42.2kg

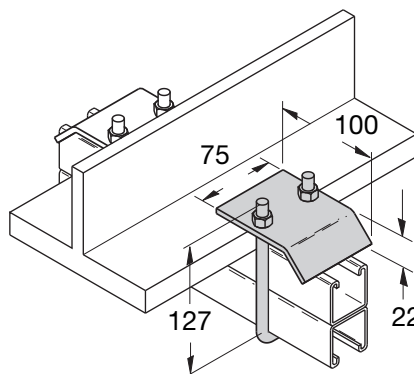

All dimensions are in millimeters unless otherwise specified.

# Index

Catalog No.	Page	Catalog No.	Page	Catalog No.	Page
9_-1204	40	125X300CD12CLVTD Series	28	150G300CD20CLHX Series	25
9_-1208	40	125X300CD12CLVTU Series	28	150G300CD20CLLR Series	31
9_-1208	40	125X300CD12ILL Series	17	150G300CD20CLRR Series	31
9SS6-CCS Series	107	125X300CD15CLCSF Series	29	150G300CD20CLRS Series	31
9SS6-CCT Series	106	125X300CD15CLET Series	32	150G300CD20CLRT Series	33
99-9982	41	125X300CD15CLHB Series	23-24	150G300CD20CLRX Series	34
99-N1	39	125X300CD15CLHT Series	25	150G300CD20CLVI Series	26-27
125G200CD15ILL Series	18	125X300CD15CLHX Series	25	150G300CD20CLVTD Series	26-27
125G200CD20ILL Series	18	125X300CD15CLLR Series	31	150G300CD20CLVTV Series	28
125G300CD12CLCSF Series	29	125X300CD15CLRR Series	31	150G300CD20ILL Series	18
125G300CD12CLET Series	32	125X300CD15CLRS Series	31	150X200CD12ILL Series	17
125G300CD12CLHB Series	23-24	125X300CD15CLRT Series	33	150X200CD15ILL Series	18
125G300CD12CLHT Series	25	125X300CD15CLRX Series	34	150X200CD20ILL Series	18
125G300CD12CLHX Series	25	125X300CD15CLVI Series	26-27	150X300CD12CLCSF Series	29
125G300CD12CLLR Series	31	125X300CD15CLVTD Series	28	150X300CD12CLET Series	32
125G300CD12CLRR Series	31	125X300CD15CLVTU Series	28	150X300CD12CLHB Series	23-24
125G300CD12CLRT Series	33	125X300CD15ILL Series	18	150X300CD12CLHT Series	25
125G300CD12CLRX Series	34	125X300CD20CLCSF Series	29	150X300CD12CLHX Series	25
125G300CD12CLVI Series	26-27	125X300CD20CLET Series	32	150X300CD12CLLR Series	31
125G300CD12CLVTD Series	26-27	125X300CD20CLHB Series	23-24	150X300CD12CLRR Series	31
125G300CD12CLVTU Series	28	125X300CD20CLHT Series	25	150X300CD12CLRS Series	31
125G300CD15ILL Series	18	125X300CD20CLHX Series	25	150X300CD12CLRT Series	33
125G300CD15CLCSF Series	29	125X300CD20CLLR Series	31	150X300CD12CLRX Series	34
125G300CD15CLET Series	32	125X300CD20CLRR Series	31	150X300CD12CLVI Series	26-27
125G300CD15CLHB Series	23-24	125X300CD20CLRS Series	31	150X300CD12CLVTD Series	28
125G300CD15CLHT Series	25	125X300CD20CLRT Series	33	150X300CD12CLVTV Series	28
125G300CD15CLHX Series	25	125X300CD20CLRX Series	34	150X300CD12ILL Series	17
125G300CD15CLLR Series	31	125X300CD20CLVI Series	26-27	150X300CD15ILL Series	18
125G300CD15CLRR Series	31	125X300CD20CLVTD Series	28	150G200CD20ILL Series	18
125G300CD15CLRS Series	31	125X300CD20CLVTU Series	28	150G300CD12CLCSF Series	29
125G300CD15CLRT Series	33	125X300CD20ILL Series	18	150G300CD12CLCF Series	29
125G300CD15CLRX Series	34	150G200CD15ILL Series	18	150G300CD12CLET Series	32
125G300CD15CLVI Series	26-27	150G200CD20ILL Series	18	150G300CD12CLHB Series	23-24
125G300CD15CLVTD Series	26-27	150G300CD12CLCSF Series	29	150G300CD12CLHT Series	25
125G300CD15CLVTU Series	28	150G300CD12CLET Series	32	150G300CD12CLHX Series	25
125G300CD20ILL Series	18	150G300CD12CLLR Series	31	150G300CD12CLRR Series	31
125G300CD20CLCSF Series	29	150G300CD12CLRR Series	31	150G300CD12CLRS Series	31
125G300CD20CLET Series	32	150G300CD12CLRT Series	33	150G300CD12CLRT Series	33
125G300CD20CLHB Series	23-24	150G300CD12CLRX Series	34	150G300CD12CLRX Series	34
125G300CD20CLHT Series	25	150G300CD12CLVI Series	26-27	150G300CD12CLVTD Series	28
125G300CD20CLHX Series	25	150G300CD12CLVTD Series	28	150G300CD12CLVTV Series	28
125G300CD20CLLR Series	31	150G300CD15ILL Series	18	150G300CD15CLCSF Series	29
125G300CD20CLRR Series	31	150G300CD15CLET Series	32	150G300CD15CLHB Series	23-24
125G300CD20CLRS Series	31	150G300CD15CLHT Series	25	150G300CD15CLHX Series	25
125G300CD20CLRT Series	33	150G300CD15CLLR Series	31	150G300CD15CLRR Series	31
125G300CD20CLRX Series	34	150G300CD15CLRS Series	31	150G300CD15CLRT Series	33
125G300CD20CLVI Series	26-27	150G300CD15CLRT Series	33	150G300CD15CLRX Series	34
125G300CD20CLVTD Series	26-27	150G300CD15CLRX Series	34	150G300CD15CLVI Series	26-27
125G300CD20CLVTU Series	28	150G300CD15CLVTD Series	28	150G300CD15CLVTD Series	28
125X200CD12ILL Series	17	150G300CD15CLVTU Series	28	150G300CD15CLVTV Series	28
125X200CD15ILL Series	18	150G300CD15CLVTV Series	28	150G300CD15ILL Series	18
125X200CD20ILL Series	18	150G300CD15CLET Series	32	150G300CD20CLCSF Series	29
125X300CD12CLCSF Series	29	150G300CD15CLHB Series	23-24	150G300CD20CLET Series	32
125X300CD12CLET Series	32	150G300CD15CLHT Series	25	150G300CD20CLHB Series	23-24
125X300CD12CLHB Series	23-24	150G300CD15CLHX Series	25	150G300CD20CLHT Series	25
125X300CD12CLHT Series	25	150G300CD15CLLR Series	31	150G300CD20CLHX Series	25
125X300CD12CLHX Series	25	150G300CD15CLRR Series	31	150G300CD20CLLR Series	31
125X300CD12CLLR Series	31	150G300CD15CLRS Series	31	150G300CD20CLRX Series	34
125X300CD12CLRR Series	31	150G300CD15CLRT Series	33	150G300CD20CLVI Series	26-27
125X300CD12CLRS Series	31	150G300CD15CLRX Series	34	150X300CD20CLVTD Series	26-27
125X300CD12CLRT Series	33	150G300CD15CLVI Series	26-27	150X300CD20CLVTV Series	28
125X300CD12CLRX Series	34	150G300CD15CLVTD Series	28	150X300CD20ILL Series	18
125X300CD12CLVI Series	26-27	150G300CD15CLVTV Series	28	AAHDW	62, 88
125X300CD12CLVTD Series	26-27	150G300CD15CLVTV Series	28	ATR M_ Series	128
125X300CD12CLVTV Series	28	150G300CD15CLET Series	32	B22 Series	121-122
150G300CD12CLCSF Series	29	150G300CD15CLHB Series	23-24	B22A Series	121-122
150G300CD12CLET Series	32	150G300CD15CLHT Series	25	B22SH Series	121-122
150G300CD12CLHB Series	23-24	150G300CD15CLHX Series	25	B52 Series	123-124
150G300CD12CLHT Series	25	150G300CD15CLLR Series	31	B52SH Series	123-124
150G300CD12CLHX Series	25	150G300CD15CLRS Series	31	B101	130
150G300CD12CLLR Series	31	150G300CD15CLRT Series	33	B102	131
150G300CD12CLRR Series	31	150G300CD15CLRX Series	34		
150G300CD12CLRS Series	31	150G300CD15CLVTD Series	28		
150G300CD12CLRT Series	33	150G300CD15CLVTU Series	28		
150G300CD12CLRX Series	34	150G300CD15CLVTV Series	28		
150G300CD12CLVI Series	26-27	150G300CD15ILL Series	18		
150G300CD12CLVTD Series	26-27	150G300CD20CLCSF Series	29		
150G300CD12CLVTV Series	28	150G300CD20CLET Series	32		
150G300CD15ILL Series	18	150G300CD20CLHB Series	23-24		
150G300CD15CLCSF Series	29	150G300CD20CLHT Series	25		
150G300CD15CLET Series	32	150G300CD20CLHX Series	25		
150G300CD15CLHB Series	23-24	150G300CD20CLLR Series	31		
150G300CD15CLHT Series	25	150G300CD20CLRX Series	34		
150G300CD15CLHX Series	25	150G300CD20CLVI Series	26-27		
150G300CD15CLLR Series	31	150X300CD20CLVTD Series	26-27		
150G300CD15CLRS Series	31	150X300CD20CLVTV Series	28		
150G300CD15CLRT Series	33	150X300CD20ILL Series	18		
150G300CD15CLRX Series	34	AAHDW	62, 88		
150G300CD15CLVI Series	26-27	ATR M_ Series	128		
150G300CD15CLVTD Series	26-27	B22 Series	121-122		
150G300CD15CLVTV Series	28	B22A Series	121-122		
150G300CD15ILL Series	18	B22SH Series	121-122		
150G300CD20CLCSF Series	29	B52 Series	123-124		
150G300CD15CLET Series	32	B52SH Series	123-124		
150G300CD15CLHB Series	23-24	B101	130		
150G300CD15CLHT Series	25	B102	131		

Catalog No.	Page	Catalog No.	Page	Catalog No.	Page
B103	131	CCFSG15LVTD Series	35	P025VC_10SS-NA Series	55
B104	131	CCFSG15LVTU Series	35	P025VC_10SS-SA Series	81
B107	131	CCFSX10LCSF Series	35	P025VC_15SS-NA Series	55
B129	130	CCFSX10LET Series	35	P025VC_15SS-SA Series	81
B133	130	CCFSX10LHB Series	35	P025VC_20SS-NA Series	55
B140	130	CCFSX10LHT Series	35	P025VC_20SS-SA Series	81
B141	130	CCFSX10LHX Series	35	P050SC_10SS-NA Series	56
B143	130	CCFSX10LLR Series	35	P050SC_10SS-SA Series	82
B201	130	CCFSX10LRR Series	35	P050SC_15SS-NA Series	56
B201-D	130	CCFSX10LRT Series	35	P050SC_15SS-SA Series	82
B202	130	CCFSX10LRX Series	35	P050SC_20SS-NA Series	56
B202-D	130	CCFSX10LSR Series	35	P050SC_20SS-SA Series	82
B230	131	CCFSX10LVI Series	35	P050SR_10SS-NA Series	56
B217P	127	CCFSX10LVO Series	35	P050SR_10SS-SA Series	82
B279FL	132	CCFSX10LVTD Series	35	P050SR_15SS-NA Series	56
B281AFL	132	CCFSX10LVTU Series	35	P050SR_15SS-SA Series	82
B297 Series	131	CIFLG15LL Series	19	P050SR_20SS-NA Series	56
B341	130	CIFLG15LL Series	19	P050SR_20SS-SA Series	82
B409 Series	131	CIFSG15LL Series	19	P050VC_10SS-NA Series	56
B441-22	132	CIFSG15LL Series	19	P050VC_10SS-SA Series	82
B441-22A	132	CSCCHDW	88	P050VC_15SS-NA Series	56
B825	127	FW M_ Series	128	P050VC_15SS-SA Series	82
BCN- _ Series	39	LBE125_ Series	39	P050VC_20SS-NA Series	56
BMS- _ Series	126	LBE150_ Series	39	P050VC_20SS-SA Series	82
BMS- _M Series	126	LBD125_-1000	41	P050VR_10SS-NA Series	56
BMS- _S Series	126	LBD150_-1000	41	P050VR_10SS-SA Series	82
BRT- _ Series	39	LCCSD	20	P050VR_15SS-NA Series	56
BSPHDW	62,88	LCCSDR_	20	P050VR_15SS-SA Series	82
CCFLG15LCSF Series	35	LCH125_ Series	20	P050VR_20SS-NA Series	56
CCFLG15LET Series	35	LCH150_ Series	20	P050VR_20SS-SA Series	82
CCFLG15LHB Series	35	LCL125_	20	P075SC_10SS-NA Series	57
CCFLG15LHT Series	35	LCL150_	20	P075SC_10SS-SA Series	83
CCFLG15LHX Series	35	LDO_ Series	39	P075SC_15SS-NA Series	57
CCFLG15LLR Series	35	LES125_	37	P075SC_15SS-SA Series	83
CCFLG15LRR Series	35	LES150_	37	P075SC_20SS-NA Series	57
CCFLG15LRT Series	35	LHA125_	37	P075SC_20SS-SA Series	83
CCFLG15LRX Series	35	LHA150_	37	P075SR_10SS-NA Series	57
CCFLG15LSR Series	35	LHD-121X	40	P075SR_10SS-SA Series	83
CCFLG15LVI Series	35	LHD-123X	40	P075SR_15SS-NA Series	57
CCFLG15LVO Series	35	LHE125_	38	P075SR_15SS-SA Series	83
CCFLG15LVTD Series	35	LHE150_	38	P075SR_20SS-NA Series	57
CCFLG15LVTU Series	35	LID125_ _ Series	41	P075SR_20SS-SA Series	83
CCFLX10LCSF Series	35	LID150_ _ Series	41	P075VC_10SS-NA Series	57
CCFLX10LET Series	35	LRE125_-1000	37	P075VC_10SS-SA Series	83
CCFLX10LHB Series	35	LRE150_-1000	37	P075VC_15SS-NA Series	57
CCFLX10LHT Series	35	LRS125_	38	P075VC_15SS-SA Series	83
CCFLX10LHX Series	35	LRS150_	38	P075VC_20SS-NA Series	57
CCFLX10LLR Series	35	LSD125_-3000	41	P075VC_20SS-SA Series	83
CCFLX10LRR Series	35	LSD150_-3000	41	P075VR_10SS-NA Series	57
CCFLX10LRT Series	35	LSP125_	37	P075VR_10SS-SA Series	83
CCFLX10LRX Series	35	LSP150_	37	P075VR_15SS-NA Series	57
CCFLX10LSR Series	35	LSR125_ Series	37	P075VR_15SS-SA Series	83
CCFLX10LVI Series	35	LSR150_ Series	37	P075VR_20SS-NA Series	57
CCFLX10LVO Series	35	LTC125_	39	P075VR_20SS-SA Series	83
CCFLX10LVTD Series	35	LTC150_	39	P100SC_10SS-NA Series	58
CCFLX10LVTU Series	35	LVA125_	37	P100SC_10SS-SA Series	84
CCFSG15LCSF Series	35	LVA150_	37	P100SC_15SS-NA Series	58
CCFSG15LET Series	35	M10 SFHN	38	P100SC_15SS-SA Series	84
CCFSG15LHB Series	35	M10x20 SNCB	38	P100SC_20SS-NA Series	58
CCFSG15LHT Series	35	M_ HHCS Series	128	P100SC_20SS-SA Series	84
CCFSG15LHX Series	35	M_ HN Series	128	P100SR_10SS-NA Series	58
CCFSG15LLR Series	35	NWM_ Series	127	P100SR_10SS-SA Series	84
CCFSG15LRR Series	35	P025SC_10SS-NA Series	55	P100SR_15SS-NA Series	58
CCFSG15LRT Series	35	P025SC_10SS-SA Series	81	P100SR_15SS-SA Series	84
CCFSG15LRX Series	35	P025SC_15SS-NA Series	55	P100SR_20SS-NA Series	58
CCFSG15LSR Series	35	P025SC_15SS-SA Series	81	P100SR_20SS-SA Series	84
CCFSG15LVI Series	35	P025SC_20SS-NA Series	55	P100VC_10SS-NA Series	58
CCFSG15LVO Series	35	P025SC_20SS-SA Series	81	P100VC_10SS-SA Series	84

# Index

Catalog No.	Page	Catalog No.	Page	Catalog No.	Page
P100VC_15SS-NA Series	58	PEP075_-SA	86	P(F/M)025VC_10HX-SA Series	95
P100VC_15SS-SA Series	84	PEP100_-NA	60	PF025VC_10VI-NA Series	71-74
P100VC_20SS-NA Series	58	PEP100_-SA	86	PF025VC_10VI-SA Series	97-100
P100VC_20SS-SA Series	84	P(F/M)025SC_10HB-NA Series	64-67	PF025VC_10VO-NA Series	71-74
P100VR_10SS-NA Series	58	P(F/M)025SC_10HB-SA Series	90-93	PF025VC_10VO-SA Series	97-100
P100VR_10SS-SA Series	84	P(F/M)025SC_10HT-NA Series	68	P(F/M)025VC_15HB-NA Series	64-67
P100VR_15SS-SA Series	84	P(F/M)025SC_10HT-SA Series	94	P(F/M)025VC_15HB-SA Series	90-93
P100VR_15SS-NA Series	58	P(F/M)025SC_10HX-NA Series	69	P(F/M)025VC_15HT-NA Series	68
P100VR_20SS-SA Series	84	P(F/M)025SC_10HX-SA Series	95	P(F/M)025VC_15HT-SA Series	94
P100VR_20SS-NA Series	58	PF025SC_10VI-NA Series	71-74	P(F/M)025VC_15HX-NA Series	69
PAS_-NA	59	PF025SC_10VI-SA Series	97-100	P(F/M)025VC_15HX-SA Series	95
PBS_-1-NA	59	PF025SC_10VO-NA Series	71-74	PF025VC_15VI-NA Series	71-74
PBS_-1-SA	85	PF025SC_10VO-SA Series	97-100	PF025VC_15VI-SA Series	97-100
PBS_-2-NA	59	P(F/M)025SC_15HB-NA Series	64-67	PF025VC_15VO-NA Series	71-74
PBS_-2-SA	85	P(F/M)025SC_15HB-SA Series	90-93	PF025VC_15VO-SA Series	97-100
PBS_-3-NA	59	P(F/M)025SC_15HT-NA Series	68	P(F/M)025VC_20HB-NA Series	64-67
PBS_-3-SA	85	P(F/M)025SC_15HT-SA Series	94	P(F/M)025VC_20HB-SA Series	90-93
PBS_-4-NA	59	P(F/M)025SC_15HX-NA Series	69	P(F/M)025VC_20HT-NA Series	68
PBS_-4-SA	85	P(F/M)025SC_15HX-SA Series	95	P(F/M)025VC_20HT-SA Series	94
PBS_-5-NA	59	PF025SC_15VI-NA Series	71-74	P(F/M)025VC_20HX-NA Series	69
PBS_-5-SA	85	PF025SC_15VI-SA Series	97-100	P(F/M)025VC_20HX-SA Series	95
PBS_-6-NA	59	PF025SC_15VO-NA Series	71-74	PF025VC_20VI-NA Series	71-74
PBS_-6-SA	85	PF025SC_15VO-SA Series	97-100	PF025VC_20VI-SA Series	97-100
PCCC025_-SA	87	P(F/M)025SC_20HB-NA Series	64-67	PF025VC_20VO-NA Series	71-74
PCCC050_-SA	87	P(F/M)025SC_20HB-SA Series	90-93	PF025VC_20VO-SA Series	97-100
PCCC075_-SA	87	P(F/M)025SC_20HT-NA Series	68	P(F/M)025VR_10HB-NA Series	64-67
PCCC100_-SA	87	P(F/M)025SC_20HT-SA Series	94	P(F/M)025VR_10HB-SA Series	90-93
PC(F/M)S_10HB-NA Series	78	P(F/M)025SC_20HX-NA Series	69	P(F/M)025VR_10HT-NA Series	68
PC(F/M)S_10HB-SA Series	104	P(F/M)025SC_20HX-SA Series	95	P(F/M)025VR_10HT-SA Series	94
PC(F/M)S_10HT-NA Series	78	PF025SC_20VI-NA Series	71-74	P(F/M)025VR_10HX-NA Series	69
PC(F/M)S_10HT-SA Series	104	PF025SC_20VI-SA Series	97-100	P(F/M)025VR_10HX-SA Series	95
PC(F/M)S_10HX-NA Series	78	PF025SC_20VO-NA Series	71-74	PF025VR_10VI-NA Series	71-74
PC(F/M)S_10HX-SA Series	104	PF025SC_20VO-SA Series	97-100	PF025VR_10VI-SA Series	97-100
PC(F/M)S_10LR-NA Series	78	P(F/M)025SR_10HB-NA Series	64-67	PF025VR_10VO-NA Series	71-74
PC(F/M)S_10LR-SA Series	104	P(F/M)025SR_10HB-SA Series	90-93	PF025VR_10VO-SA Series	97-100
PC(F/M)S_10RR-NA Series	78	P(F/M)025SR_10HT-NA Series	68	P(F/M)025VR_15HB-NA Series	64-67
PC(F/M)S_10RR-SA Series	104	P(F/M)025SR_10HT-SA Series	94	P(F/M)025VR_15HB-SA Series	90-93
PC(F/M)S_10SR-NA Series	78	P(F/M)025SR_10HX-NA Series	69	P(F/M)025VR_15HT-NA Series	68
PC(F/M)S_10SR-SA Series	104	P(F/M)025SR_10HX-SA Series	95	P(F/M)025VR_15HT-SA Series	94
PCFS_10SS-NA Series	76	PF025SR_10VI-NA Series	71-74	P(F/M)025VR_15HX-NA Series	69
PCFS_10SS-SA Series	102	PF025SR_10VI-SA Series	97-100	P(F/M)025VR_15HX-SA Series	95
PC(F/M)S_10VI-NA Series	78	PF025SR_10VO-NA Series	71-74	PF025VR_15VI-NA Series	71-74
PC(F/M)S_10VI-SA Series	104	PF025SR_10VO-SA Series	97-100	PF025VR_15VI-SA Series	97-100
PC(F/M)S_10VO-NA Series	78	P(F/M)025SR_15HB-NA Series	64-67	PF025VR_15VO-NA Series	71-74
PC(F/M)S_10VO-SA Series	104	P(F/M)025SR_15HB-SA Series	90-93	PF025VR_15VO-SA Series	97-100
PC(F/M)S_15HB-NA Series	78	P(F/M)025SR_15HT-NA Series	68	P(F/M)025VR_20HB-NA Series	64-67
PC(F/M)S_15HB-SA Series	104	P(F/M)025SR_15HT-SA Series	94	P(F/M)025VR_20HB-SA Series	90-93
PC(F/M)S_15HT-NA Series	78	P(F/M)025SR_15HX-NA Series	69	P(F/M)025VR_20HT-NA Series	68
PC(F/M)S_15HT-SA Series	104	P(F/M)025SR_15HX-SA Series	95	P(F/M)025VR_20HT-SA Series	94
PC(F/M)S_15HX-NA Series	78	PF025SR_15VI-NA Series	71-74	P(F/M)025VR_20HX-NA Series	69
PC(F/M)S_15HX-SA Series	104	PF025SR_15VI-SA Series	97-100	P(F/M)025VR_20HX-SA Series	95
PC(F/M)S_15LR-NA Series	78	PF025SR_15VO-NA Series	71-74	PF025VR_20VI-NA Series	71-74
PC(F/M)S_15LR-SA Series	104	PF025SR_15VO-SA Series	97-100	PF025VR_20VI-SA Series	97-100
PC(F/M)S_15RR-NA Series	78	P(F/M)025SR_20HB-NA Series	64-67	PF025VR_20VO-NA Series	71-74
PC(F/M)S_15RR-SA Series	104	P(F/M)025SR_20HB-SA Series	90-93	PF025VR_20VO-SA Series	97-100
PC(F/M)SS_15SR-NA Series	78	P(F/M)025SR_20HT-NA Series	68	P(F/M)050SC_10HB-NA Series	64-67
PC(F/M)S_15SR-SA Series	104	P(F/M)025SR_20HT-SA Series	94	P(F/M)050SC_10HB-SA Series	90-93
PCFS_15SS-NA Series	76	P(F/M)025SR_20HX-NA Series	69	P(F/M)050SC_10HT-NA Series	68
PCFS_15SS-SA Series	102	P(F/M)025SR_20HX-SA Series	95	P(F/M)050SC_10HT-SA Series	94
PC(F/M)S_15VI-NA Series	78	PF025SR_20VI-NA Series	71-74	P(F/M)050SC_10HX-NA Series	69
PC(F/M)S_15VI-SA Series	104	PF025SR_20VI-SA Series	97-100	P(F/M)050SC_10HX-SA Series	95
PC(F/M)S_15VO-NA Series	78	PF025SR_20VO-NA Series	71-74	PF050SC_10VI-NA Series	71-74
PC(F/M)S_15VO-SA Series	104	PF025SR_20VO-SA Series	97-100	PF050SC_10VI-SA Series	97-100
PCMS_15VO-SA Series	104	P(F/M)025VC_10HB-NA Series	64-67	PF050SC_10VO-NA Series	71-74
PEP025_-NA	60	P(F/M)025VC_10HB-SA Series	90-93	PF050SC_10VO-SA Series	97-100
PEP050_-NA	60	P(F/M)025VC_10HT-NA Series	68	P(F/M)050SC_15HB-NA Series	64-67
PEP050_-SA	86	P(F/M)025VC_10HT-SA Series	94	P(F/M)050SC_15HB-SA Series	90-93
PEP075_-NA	60	P(F/M)025VC_10HX-NA Series	69	P(F/M)050SC_15HT-NA Series	68

Catalog No.	Page	Catalog No.	Page	Catalog No.	Page
P(F/M)050SC_15HT-SA Series	94	P(F/M)050VC_20HB-SA Series	90-93	PF075SC_20VO-SA Series	97-100
P(F/M)050SC_15HX-NA Series	69	P(F/M)050VC_20HT-NA Series	68	P(F/M)075SR_10HB-NA Series	64-67
P(F/M)050SC_15HX-SA Series	95	P(F/M)050VC_20HT-SA Series	94	P(F/M)075SR_10HB-SA Series	90-93
PF050SC_15VI-NA Series	71-74	P(F/M)050VC_20HX-NA Series	69	P(F/M)075SR_10HT-NA Series	68
PF050SC_15VI-SA Series	97-100	P(F/M)050VC_20HX-SA Series	95	P(F/M)075SR_10HT-SA Series	94
PF050SC_15VO-NA Series	71-74	PF050VC_20VI-NA Series	71-74	P(F/M)075SR_10HX-NA Series	69
PF050SC_15VO-SA Series	97-100	PF050VC_20VI-SA Series	97-100	P(F/M)075SR_10HX-SA Series	95
P(F/M)050SC_20HB-NA Series	64-67	PF050VC_20VO-NA Series	71-74	PF075SR_10VI-NA Series	71-74
P(F/M)050SC_20HB-SA Series	90-93	PF050VC_20VO-SA Series	97-100	PF075SR_10VI-SA Series	97-100
P(F/M)050SC_20HT-NA Series	68	P(F/M)050VR_10HB-NA Series	64-67	PF075SR_10VO-NA Series	71-74
P(F/M)050SC_20HT-SA Series	94	P(F/M)050VR_10HB-SA Series	90-93	PF075SR_10VO-SA Series	97-100
P(F/M)050SC_20HX-NA Series	69	P(F/M)050VR_10HT-NA Series	68	P(F/M)075SR_15HB-NA Series	64-67
P(F/M)050SC_20HX-SA Series	95	P(F/M)050VR_10HT-SA Series	94	P(F/M)075SR_15HB-SA Series	90-93
PF050SC_20VI-NA Series	71-74	P(F/M)050VR_10HX-NA Series	69	P(F/M)075SR_15HT-NA Series	68
PF050SC_20VI-SA Series	97-100	P(F/M)050VR_10HX-SA Series	95	P(F/M)075SR_15HT-SA Series	94
PF050SC_20VO-NA Series	71-74	PF050VR_10VI-NA Series	71-74	P(F/M)075SR_15HX-NA Series	69
PF050SC_20VO-SA Series	97-100	PF050VR_10VI-SA Series	97-100	P(F/M)075SR_15HX-SA Series	95
P(F/M)050SR_10HB-NA Series	64-67	PF050VR_10VO-NA Series	71-74	PF075SR_15VI-NA Series	71-74
P(F/M)050SR_10HB-SA Series	90-93	PF050VR_10VO-SA Series	97-100	PF075SR_15VI-SA Series	97-100
P(F/M)050SR_10HT-NA Series	68	P(F/M)050VR_15HB-NA Series	64-67	PF075SR_15VO-NA Series	71-74
P(F/M)050SR_10HT-SA Series	94	P(F/M)050VR_15HB-SA Series	90-93	PF075SR_15VO-SA Series	97-100
P(F/M)050SR_10HX-NA Series	69	P(F/M)050VR_15HT-NA Series	68	P(F/M)075SR_20HB-NA Series	64-67
P(F/M)050SR_10HX-SA Series	95	P(F/M)050VR_15HT-SA Series	94	P(F/M)075SR_20HB-SA Series	90-93
PF050SR_10VI-NA Series	71-74	P(F/M)050VR_15HX-NA Series	69	P(F/M)075SR_20HT-NA Series	68
PF050SR_10VI-SA Series	97-100	P(F/M)050VR_15HX-SA Series	95	P(F/M)075SR_20HT-SA Series	94
PF050SR_10VO-NA Series	71-74	PF050VR_15VI-NA Series	71-74	P(F/M)075SR_20HX-NA Series	69
PF050SR_10VO-SA Series	97-100	PF050VR_15VI-SA Series	97-100	P(F/M)075SR_20HX-SA Series	95
P(F/M)050SR_15HB-NA Series	64-67	PF050VR_15VO-NA Series	71-74	PF075SR_20VI-NA Series	71-74
P(F/M)050SR_15HB-SA Series	90-93	PF050VR_15VO-SA Series	97-100	PF075SR_20VI-SA Series	97-100
P(F/M)050SR_15HT-NA Series	68	P(F/M)050VR_20HB-NA Series	64-67	PF075SR_20VO-NA Series	71-74
P(F/M)050SR_15HT-SA Series	94	P(F/M)050VR_20HB-SA Series	90-93	PF075SR_20VO-SA Series	97-100
P(F/M)050SR_15HX-NA Series	69	P(F/M)050VR_20HT-NA Series	68	P(F/M)075VC_10HB-NA Series	64-67
P(F/M)050SR_15HX-SA Series	95	P(F/M)050VR_20HT-SA Series	94	P(F/M)075VC_10HB-SA Series	90-93
PF050SR_15VI-NA Series	71-74	P(F/M)050VR_20HX-NA Series	69	P(F/M)075VC_10HT-NA Series	68
PF050SR_15VI-SA Series	97-100	P(F/M)050VR_20HX-SA Series	95	P(F/M)075VC_10HT-SA Series	94
PF050SR_15VO-NA Series	71-74	PF050VR_20VI-NA Series	71-74	P(F/M)075VC_10HX-NA Series	69
PF050SR_15VO-SA Series	97-100	PF050VR_20VI-SA Series	97-100	P(F/M)075VC_10HX-SA Series	95
P(F/M)050SR_20HB-NA Series	64-67	PF050VR_20VO-NA Series	71-74	PF075VC_10VI-NA Series	71-74
P(F/M)050SR_20HB-SA Series	90-93	PF050VR_20VO-SA Series	97-100	PF075VC_10VI-SA Series	97-100
P(F/M)050SR_20HT-NA Series	68	P(F/M)075SC_10HB-NA Series	64-67	PF075VC_10VO-NA Series	71-74
P(F/M)050SR_20HT-SA Series	94	P(F/M)075SC_10HB-SA Series	90-93	PF075VC_10VO-SA Series	97-100
P(F/M)050SR_20HX-NA Series	69	P(F/M)075SC_10HT-NA Series	68	P(F/M)075VC_15HB-NA Series	64-67
P(F/M)050SR_20HX-SA Series	95	P(F/M)075SC_10HT-SA Series	94	P(F/M)075VC_15HB-SA Series	90-93
PF050SR_20VI-NA Series	71-74	P(F/M)075SC_10HT-SA Series	94	P(F/M)075VC_15HT-NA Series	68
PF050SR_20VI-SA Series	97-100	P(F/M)075SC_10HX-NA Series	69	P(F/M)075VC_15HT-SA Series	94
PF050SR_20VO-NA Series	71-74	P(F/M)075SC_10HX-SA Series	95	P(F/M)075VC_15HX-NA Series	69
PF050SR_20VO-SA Series	97-100	PF050VR_20VI-NA Series	71-74	P(F/M)075VC_15HX-SA Series	95
P(F/M)050VC_10HB-NA Series	64-67	PF050VR_20VI-SA Series	97-100	PF075VC_15VI-NA Series	71-74
P(F/M)050VC_10HB-SA Series	90-93	PF075SC_10VO-NA Series	71-74	PF075VC_15VI-SA Series	97-100
P(F/M)050VC_10HT-NA Series	68	PF075SC_10VO-SA Series	97-100	PF075VC_15VO-NA Series	71-74
P(F/M)050VC_10HT-SA Series	94	P(F/M)075SC_15HB-NA Series	64-67	PF075VC_15VO-SA Series	97-100
P(F/M)050VC_10HX-NA Series	69	P(F/M)075SC_15HB-SA Series	90-93	PF075VC_15VO-SA Series	97-100
P(F/M)050VC_10HX-SA Series	95	P(F/M)075SC_15HT-NA Series	68	PF075VC_20HB-NA Series	64-67
PF050VC_10VI-NA Series	71-74	P(F/M)075SC_15HT-SA Series	94	P(F/M)075VC_20HB-SA Series	90-93
PF050VC_10VI-SA Series	97-100	P(F/M)075SC_15HT-SA Series	94	P(F/M)075VC_20HT-NA Series	68
PF050VC_10VO-NA Series	71-74	P(F/M)075SC_15HX-NA Series	69	P(F/M)075VC_20HT-SA Series	94
PF050VC_10VO-SA Series	97-100	P(F/M)075SC_15HX-SA Series	95	P(F/M)075VC_20HX-NA Series	69
P(F/M)050VC_15HB-NA Series	64-67	P(F/M)075SC_15HX-SA Series	95	P(F/M)075VC_20HX-SA Series	95
P(F/M)050VC_15HB-SA Series	90-93	PF075SC_15VI-NA Series	71-74	PF075VC_20VI-NA Series	71-74
P(F/M)050VC_15HT-NA Series	68	PF075SC_15VI-SA Series	97-100	PF075VC_20VI-SA Series	97-100
P(F/M)050VC_15HT-SA Series	94	PF075SC_15VO-NA Series	71-74	PF075VC_20VO-NA Series	71-74
P(F/M)050VC_15HX-NA Series	69	PF075SC_15VO-SA Series	97-100	PF075VC_20VO-SA Series	97-100
P(F/M)050VC_15HX-SA Series	95	P(F/M)075SC_20HB-NA Series	64-67	PF075VC_20VO-NA Series	97-100
PF050VC_15VI-NA Series	71-74	P(F/M)075SC_20HB-SA Series	90-93	PF075VC_20VNA Series	71-74
PF050VC_15VI-SA Series	97-100	P(F/M)075SC_20HT-NA Series	68	PF075VC_20VNA Series	97-100
PF050VC_15VO-NA Series	71-74	P(F/M)075SC_20HT-SA Series	94	PF075VC_20VNA Series	97-100
PF050VC_15VO-SA Series	97-100	P(F/M)075SC_20HT-SA Series	94	PF075VC_20VNA Series	97-100
P(F/M)050VC_20HB-NA Series	64-67	P(F/M)075SC_20HX-NA Series	69	PF075VC_20VNA Series	97-100
		P(F/M)075SC_20HX-SA Series	95		
		PF075SC_20VI-NA Series	71-74		
		PF075SC_20VI-SA Series	97-100		
		PF075SC_20VO-NA Series	71-74		

# Index

Catalog No.	Page	Catalog No.	Page	Catalog No.	Page
PF075VR_10VI-SA Series	97-100	P(F/M)100SR_15HX-SA Series	95	P(F/M)100VR_20HT-SA Series	94
PF075VR_10VO-NA Series	71-74	PF100SR_15VI-NA Series	71-74	P(F/M)100VR_20HX-NA Series	69
PF075VR_10VO-SA Series	97-100	PF100SR_15VI-SA Series	97-100	P(F/M)100VR_20HX-SA Series	95
P(F/M)075VR_15HB-NA Series	64-67	PF100SR_15VO-NA Series	71-74	PF100VR_20VI-NA Series	71-74
P(F/M)075VR_15HB-SA Series	90-93	PF100SR_15VO-SA Series	97-100	PF100VR_20VI-SA Series	97-100
P(F/M)075VR_15HT-NA Series	68	P(F/M)100SR_20HB-NA Series	64-67	PF100VR_20VO-NA Series	71-74
P(F/M)075VR_15HT-SA Series	94	P(F/M)100SR_20HB-SA Series	90-93	PF100VR_20VO-SA Series	97-100
P(F/M)075VR_15HX-NA Series	69	P(F/M)100SR_20HT-NA Series	68	PHA025_-NA	60
P(F/M)075VR_15HX-SA Series	95	P(F/M)100SR_20HT-SA Series	94	PHA050_-NA	60
PF075VR_15VI-NA Series	71-74	P(F/M)100SR_20HX-NA Series	69	PHA050_-SA	85
PF075VR_15VI-SA Series	97-100	P(F/M)100SR_20HX-SA Series	95	PHA075_-NA	60
PF075VR_15VO-NA Series	71-74	PF100SR_20VI-NA Series	71-74	PHA075_-SA	85
PF075VR_15VO-SA Series	97-100	PF100SR_20VI-SA Series	97-100	PHA100_-NA	60
P(F/M)075VR_20HB-NA Series	64-67	PF100SR_20VO-NA Series	71-74	PHA100_-SA	85
P(F/M)075VR_20HB-SA Series	90-93	PF100SR_20VO-SA Series	97-100	PHD025_-NA	62
P(F/M)075VR_20HT-NA Series	68	P(F/M)100VC_10HB-NA Series	64-67	PHD025_-SA	87
P(F/M)075VR_20HT-SA Series	94	P(F/M)100VC_10HB-SA Series	90-93	PHD050_-NA	62
P(F/M)075VR_20HX-NA Series	69	P(F/M)100VC_10HT-NA Series	68	PHD050_-SA	87
P(F/M)075VR_20HX-SA Series	95	P(F/M)100VC_10HT-SA Series	94	PHD075_-NA	62
PF075VR_20VI-NA Series	71-74	P(F/M)100VC_10HX-NA Series	69	PHD075_-SA	87
PF075VR_20VI-SA Series	97-100	P(F/M)100VC_10HX-SA Series	95	PHD100_-NA	62
PF075VR_20VO-NA Series	71-74	PF100VC_10VI-NA Series	71-74	PHD100_-SA	87
PF075VR_20VO-SA Series	97-100	PF100VC_10VI-SA Series	97-100	PLR025_-NA	61
P(F/M)100SC_10HB-NA Series	64-67	PF100VC_10VO-NA Series	71-74	PLR050_-NA	61
P(F/M)100SC_10HB-SA Series	90-93	PF100VC_10VO-SA Series	97-100	PLR050_-SA	86
P(F/M)100SC_10HT-NA Series	68	P(F/M)100VC_15HB-NA Series	64-67	PLR075_-NA	61
P(F/M)100SC_10HT-SA Series	94	P(F/M)100VC_15HB-SA Series	90-93	PLR075_-SA	86
P(F/M)100SC_10HX-NA Series	69	P(F/M)100VC_15HT-NA Series	68	PLR100_-NA	61
P(F/M)100SC_10HX-SA Series	95	P(F/M)100VC_15HT-SA Series	94	PLR100_-SA	86
PF100SC_10VI-NA Series	71-74	P(F/M)100VC_15HX-NA Series	69	PM025SC_10LR-NA Series	70
PF100SC_10VI-SA Series	97-100	P(F/M)100VC_15HX-SA Series	95	PM025SC_10LR-SA Series	96
PF100SC_10VO-NA Series	71-74	PF100VC_15VI-NA Series	71-74	PM025SC_10RR-NA Series	70
PF100SC_10VO-SA Series	97-100	PF100VC_15VI-SA Series	97-100	PM025SC_10RR-SA Series	96
P(F/M)100SC_15HB-NA Series	64-67	PF100VC_15VO-NA Series	71-74	PM025SC_10SR-NA Series	70
P(F/M)100SC_15HB-SA Series	90-93	PF100VC_15VO-SA Series	97-100	PM025SC_10SR-SA Series	96
P(F/M)100SC_15HT-NA Series	68	P(F/M)100VC_20HB-NA Series	64-67	PM025SC_15LR-NA Series	70
P(F/M)100SC_15HT-SA Series	94	P(F/M)100VC_20HB-SA Series	90-93	PM025SC_15LR-SA Series	96
P(F/M)100SC_15HX-NA Series	69	P(F/M)100VC_20HT-NA Series	68	PM025SC_15RR-NA Series	70
P(F/M)100SC_15HX-SA Series	95	P(F/M)100VC_20HT-SA Series	94	PM025SC_15RR-SA Series	96
PF100SC_15VI-NA Series	71-74	P(F/M)100VC_20HX-NA Series	69	PM025SC_15SR-NA Series	70
PF100SC_15VI-SA Series	97-100	P(F/M)100VC_20HX-SA Series	95	PM025SC_15SR-SA Series	96
PF100SC_15VO-NA Series	71-74	PF100VC_20VI-NA Series	71-74	PM025SC_20LR-NA Series	70
PF100SC_15VO-SA Series	97-100	PF100VC_20VI-SA Series	97-100	PM025SC_20LR-SA Series	96
P(F/M)100SC_20HB-NA Series	64-67	PF100VC_20VO-NA Series	71-74	PM025SC_20RR-NA Series	70
P(F/M)100SC_20HB-SA Series	90-93	PF100VC_20VO-SA Series	97-100	PM025SC_20RR-SA Series	96
P(F/M)100SC_20HT-NA Series	68	P(F/M)100VR_10HB-NA Series	64-67	PM025SC_20SR-NA Series	70
P(F/M)100SC_20HT-SA Series	94	P(F/M)100VR_10HB-SA Series	90-93	PM025SC_20SR-SA Series	96
P(F/M)100SC_20HX-NA Series	69	P(F/M)100VR_10HT-NA Series	68	PM025SR_10LR-NA Series	70
P(F/M)100SC_20HX-SA Series	95	P(F/M)100VR_10HT-SA Series	94	PM025SR_10LR-SA Series	96
PF100SC_20VI-NA Series	71-74	P(F/M)100VR_10HX-NA Series	69	PM025SR_10RR-NA Series	70
PF100SC_20VI-SA Series	97-100	P(F/M)100VR_10HX-SA Series	95	PM025SR_10RR-SA Series	96
PF100SC_20VO-NA Series	71-74	PF100VR_10VI-NA Series	71-74	PM025SR_10SR-NA Series	70
PF100SC_20VO-SA Series	97-100	PF100VR_10VI-SA Series	97-100	PM025SR_10SR-SA Series	96
P(F/M)100SR_10HB-NA Series	64-67	PF100VR_10VO-NA Series	71-74	PM025SR_15LR-NA Series	70
P(F/M)100SR_10HB-SA Series	90-93	PF100VR_10VO-SA Series	97-100	PM025SR_15LR-SA Series	96
P(F/M)100SR_10HT-NA Series	68	P(F/M)100VR_15HB-NA Series	64-67	PM025SR_15RR-NA Series	70
P(F/M)100SR_10HT-SA Series	94	P(F/M)100VR_15HB-SA Series	90-93	PM025SR_15RR-SA Series	96
P(F/M)100SR_10HX-NA Series	69	P(F/M)100VR_15HT-NA Series	68	PM025SR_15SR-NA Series	70
P(F/M)100SR_10HX-SA Series	95	P(F/M)100VR_15HT-SA Series	94	PM025SR_15SR-SA Series	96
PF100SR_10VI-NA Series	71-74	P(F/M)100VR_15HX-NA Series	69	PM025SR_20LR-NA Series	70
PF100SR_10VI-SA Series	97-100	P(F/M)100VR_15HX-SA Series	95	PM025SR_20LR-SA Series	96
PF100SR_10VO-NA Series	71-74	PF100VR_15VI-NA Series	71-74	PM025SR_20RR-NA Series	70
PF100SR_10VO-SA Series	97-100	PF100VR_15VI-SA Series	97-100	PM025SR_20RR-SA Series	96
P(F/M)100SR_15HB-NA Series	64-67	PF100VR_15VO-NA Series	71-74	PM025SR_20SR-NA Series	70
P(F/M)100SR_15HB-SA Series	90-93	PF100VR_15VO-SA Series	97-100	PM025SR_20SR-SA Series	96
P(F/M)100SR_15HT-NA Series	68	P(F/M)100VR_20HB-NA Series	64-67	PM025VC_10LR-NA Series	70
P(F/M)100SR_15HT-SA Series	94	P(F/M)100VR_20HB-SA Series	90-93	PM025VC_10LR-SA Series	96
P(F/M)100SR_15HX-NA Series	69	P(F/M)100VR_20HT-NA Series	68	PM025VC_10RR-NA Series	70



# Index

Catalog No.	Page	Catalog No.	Page	Catalog No.	Page
PM100SR_15RR-SA Series	96	PWCC050_-NA	61		
PM100SR_15SR-NA Series	70	PWCC050_-SA	87		
PM100SR_15SR-SA Series	96	PWCC075_-NA	61		
PM100SR_20LR-NA Series	70	PWCC075_-SA	87		
PM100SR_20LR-SA Series	96	PWCC100_-NA	61		
PM100SR_20RR-NA Series	70	PWCC100_-SA	87		
PM100SR_20RR-SA Series	96	SLNM_Series	127		
PM100SR_20SR-NA Series	70	SLWNM_Series	127		
PM100SR_20SR-SA Series	96	WACCHDW	88		
PM100VC_10LR-NA Series	70				
PM100VC_10LR-SA Series	96				
PM100VC_10RR-NA Series	70				
PM100VC_10RR-SA Series	96				
PM100VC_10SR-NA Series	70				
PM100VC_10SR-SA Series	96				
PM100VC_15LR-NA Series	70				
PM100VC_15LR-SA Series	96				
PM100VC_15RR-NA Series	70				
PM100VC_15RR-SA Series	96				
PM100VC_15SR-NA Series	70				
PM100VC_15SR-SA Series	96				
PM100VC_20LR-NA Series	70				
PM100VC_20LR-SA Series	96				
PM100VC_20RR-NA Series	70				
PM100VC_20RR-SA Series	96				
PM100VC_20SR-NA Series	70				
PM100VC_20SR-SA Series	96				
PM100VR_10LR-NA Series	70				
PM100VR_10LR-SA Series	96				
PM100VR_10RR-NA Series	70				
PM100VR_10RR-SA Series	96				
PM100VR_10SR-NA Series	70				
PM100VR_10SR-SA Series	96				
PM100VR_15LR-NA Series	70				
PM100VR_15LR-SA Series	96				
PM100VR_15RR-NA Series	70				
PM100VR_15RR-SA Series	96				
PM100VR_15SR-NA Series	70				
PM100VR_15SR-SA Series	96				
PM100VR_20LR-NA Series	70				
PM100VR_20LR-SA Series	96				
PM100VR_20RR-NA Series	70				
PM100VR_20RR-SA Series	96				
PM100VR_20SR-NA Series	70				
PM100VR_20SR-SA Series	96				
PSP025_-NA	59				
PSP050_-NA	59				
PSP050_-SA	85				
PSP075_-NA	59				
PSP075_-SA	85				
PSP100_-NA	59				
PSP100_-SA	85				
PSR025_-NA	61				
PSR050_-NA	61				
PSR050_-SA	86				
PSR075_-NA	61				
PSR075_-SA	86				
PSR100_-NA	61				
PSR100_-SA	86				
PVA025_-NA	60				
PVA050_-NA	60				
PVA050_-SA	86				
PVA075_-NA	60				
PVA075_-SA	86				
PVA100_-NA	60				
PVA100_-SA	86				
PWCC025_-NA	61				
PWCC025_-SA	87				



**Eaton's B-Line Business  
United States**  
509 West Monroe Street  
Highland, IL 62249  
United States  
Phone: 800-851-7415  
[www.cooperblines.com/contactus](http://www.cooperblines.com/contactus)

**Eaton's B-Line Business  
Canada**  
5925 McLaughlin Road  
Mississauga, ON L5R 1B8  
Canada  
Phone: 800-569-3660  
[www.cooperblines.com/contactca](http://www.cooperblines.com/contactca)

**Eaton's B-Line Business  
United Kingdom**  
Walrow, Highbridge  
Somerset, TA9 4AQ  
United Kingdom  
Phone: +44 (0) 1278 772600  
[www.cooperblines.com/contactuk](http://www.cooperblines.com/contactuk)

**Eaton's B-Line Business  
Saudi Arabia**  
PO Box 70160 - Al Khobar - 31952  
Kingdom of Saudi Arabia  
Phone: 00966 3 812 2236  
[www.cooperblines.com/contactme](http://www.cooperblines.com/contactme)

**Eaton's Cooper Singapore**  
No. 2 Serangoon North Ave. 5  
#06-01 Fu Yu Building, 554911  
Singapore  
Phone: +65 (0) 62974849

**Eaton's Cooper Korea Co., Ltd.**  
13 FI Vision Tower, 7072 Yeoksam-dong  
Gangnam-gu  
Seoul, 135-080  
Korea  
Phone: +44 (0) 1278 772600

Eaton  
1000 Eaton Boulevard  
Cleveland, OH 44122  
United States  
[Eaton.com](http://Eaton.com)

B-Line Business  
509 West Monroe Street  
Highland, IL 62249  
Phone: 800-851-7415  
Fax: 618-654-1917  
[www.cooperblines.com](http://www.cooperblines.com)

© 2013 Eaton  
All Rights Reserved  
Printed in USA  
Publication No. CSS-13  
August 2013

Eaton is a registered trademark

All other trademarks are property  
of their respective owners.